

SECTION 24
Maintenance, Repair & Operations

ABSORBENT		CHALK		CUTTING	
Oil.....	24-22, 24-53-57	Railroad.....	24-27	Oil.....	24-16, 24-48-49
ACCELERATORS		CLEANER/DEGREASER		DEGREASER	24-20, 24-31
Adhesives.....	24-42	Solvent.....	24-20	DE-ICER	
ADHESIVES		CLEANERS		Calcium Chloride.....	24-22
Accelerators.....	24-42	All Purpose.....	24-19	DISINFECTANT/DEODORIZER	24-24, 24-66
Activators.....	24-42	Anti-Vandal Spray.....	24-19	DISPENSER	
Contact.....	24-22	Aqua Power.....	24-31	Grease.....	24-4-5
Epoxies.....	24-32-33	Battery.....	24-31	Tape.....	24-68
Gasketing.....	24-34	Biodegradable.....	24-31, 24-48, 24-66	DOWEL	
Sealants.....	24-34, 24-46	Brake.....	24-48	Pins.....	24-59
AEROSOL		Cable.....	24-48	DRAIN PAN	24-53
Paints.....	24-18	Cleaner/Degreaser.....	24-19-21, 24-24, 24-31, 24-48, 24-66	DRILL	
ANTI-SEIZE LUBRICANTS	24-35-36	Contact.....	24-20-21, 24-31, 24-47	Rod.....	24-64-65
ANTI-SLIP COATING	24-30	Degreasers.....	24-20, 24-31	DUCT	
ANTI-SPLATTER-WELDING	24-21	Descaler.....	24-66	Type.....	24-67
ANTI-VANDAL SPRAY	24-19	Disinfectant/Deodorizer.....	24-66	DYE PENETRANT INSPECTION SYSTEMS	24-21
BATTERY		Electronics Dust Blaster.....	24-47	E-CLIPS	24-58
Cleaner.....	24-31	Gasket Remover.....	24-31	ELECTRICAL	
Terminal Coating.....	24-21, 24-31	Glass.....	24-31	Tape.....	24-68
BEARING		Hand.....	24-37, 24-67	EPOXIES	
Grease.....	24-50-51	Paint Stripper.....	24-31	Adhesives.....	24-32-33
Packer.....	24-4	Parts.....	24-31, 24-66	Applicator Guns.....	24-32
BELT		Plastic.....	24-31, 24-47	Coating.....	24-32-33
Dressings.....	24-20, 24-32	Radiator.....	24-31	Floor Repair.....	24-33
Repair.....	24-30-31	Varnish Remover.....	24-31	Grout.....	24-33
BOOMS		CLEVIS		Mixing Nozzles.....	24-32
Sorbents.....	24-55-56	Pins.....	24-60	Mold Release.....	24-20
BRAKE		CLIPS		Putty.....	24-32-33
Cleaner.....	24-48	E.....	24-58	Sticks.....	24-32
BROOMS		Hitch Pin.....	24-58	FEELER GAUGE	24-60-61
Corn.....	24-23	COATINGS		FILTER WRENCHES	24-53
Dust Pans.....	24-23	Anti-Slip.....	24-30	FITTINGS	
Floor.....	24-23	Battery Terminal.....	24-21, 24-31	Drive Tool.....	24-14
Garage.....	24-23	Cold Galvanizing.....	24-19, 24-69	Grease.....	24-8-14, 24-59-60
Handle Braces.....	24-23	Electrical.....	24-20-21, 24-31, 24-47	Remover.....	24-14
Handles.....	24-23	Epoxies.....	24-32-33	FLANGE	
Mill.....	24-23	Flooring & Grout.....	24-33	Sealant.....	24-39-40
Street.....	24-23	Mold Releases.....	24-20	FLAT STOCK STEEL	24-64
Warehouse.....	24-23	Rubber.....	24-32	FLOOR	
Wisk.....	24-23	Rust Inhibitors.....	24-19-21, 24-32, 24-35-36, 24-51, 24-69	Epoxies.....	24-33
BRUSHES		Urethane.....	24-33, 24-38	Repair.....	24-33
Auto.....	24-23	Vinyl.....	24-19	FLUORESCENT	
Counter Dusters.....	24-23	COMPOUND		Paint.....	24-18
Dairy.....	24-23	Cold Galvanizing.....	24-19, 24-69	FLUX	
Paint.....	24-23	Lapping.....	24-36	Soldering Paste.....	24-28
Pot.....	24-23	Machining.....	24-36	FOAM	
Scrub.....	24-23	Retaining.....	24-41	Sealants.....	24-67
Wire Scratch.....	24-23	Sweeping.....	24-22	Tape.....	24-68
BUCKET		Wearing.....	24-37	FOIL	
Pumps.....	24-3-7	CORROSION PREVENTION		Tape.....	24-67
CABLE		Cold Galvanizing.....	24-19, 24-69	FOOD GRADE	
Cleaner.....	24-48	Electrical.....	24-20-21, 24-31, 24-47	Lubricant.....	24-17, 24-35-36, 24-50
CALCIUM CHLORIDE	24-22	Inhibitors.....	24-19-21, 24-32, 24-35-36, 24-69	Mold Release.....	24-20
CARTRIDGES		Kleer Kote.....	24-19	FUNNELS	24-53
Grease Gun.....	24-35-36, 24-50-51	Rubberized.....	24-32	GASKET	
CAULK	24-47	Vinyl Coating.....	24-19	Adhesives.....	24-34
CEMENT, PVC PIPE	24-29	COTTER		<i>- continues -</i>	
CHAIN		Pins.....	24-58		
Lubricants.....	24-50	CRAYON			
		Lumber.....	24-28		

24
Maintenance
Repair
Operations

SECTION INDEX

SECTION 24

Maintenance, Repair & Operations

Eliminators24-39
Flange24-39-40
Remover24-31
Sealant.....24-34, 24-39-40
Silicone24-34, 24-40

GAUGE
Feeler/Thickness24-60-61

GEAR OIL.....24-51

GLASS
Cleaner.....24-31

GRAPHITE
Lubricants.....24-17

GREASE
Aerosol24-50
Anti-seize24-35-36
Aqua24-51
Bearing Grease24-50-51
Bearing Packer.....24-4
Bucket Pumps24-3-7
Cartridges24-35-36, 24-50-51
Dielectric24-35-36
Dispensers24-4
Dispensing Valves24-7
Extreme Pressure24-35-36
Fittings, Hydraulic24-8-14, 24-59-60
Food Grade24-17, 24-35-36, 24-50
Gun Adapters/Brushings24-5, 24-53
Gun Couplers24-52
Gun Extensions24-2-3, 24-5, 24-53
Gun Holders24-53
Gun Hoses.....24-3, 24-52
Guns24-1-2, 24-52
Header Block.....24-15
High Load24-51
High Pressure24-35-36, 24-50
High Temperature24-17, 24-35-36, 24-50
Hose Swivels.....24-5
Injectors24-5, 24-53
Lithium24-17, 24-35-36, 24-50
Loader Couplers.....24-4
Loader Fittings24-4
Loader Pumps.....24-4-7
Low Temperature24-50
Moly24-17-18, 24-35-36, 24-50
Open Gear24-17
Pumps24-3-7
Red.....24-50
Rust & Corrosion Inhibitor24-19, 24-32
Silicone24-35-36, 24-50
Synthetic24-35-36

GROUT
Epoxies24-33
Repair.....24-33

GUNS
Grease24-1-2, 24-52

HAND
Cleaner24-37, 24-67

HITCH PIN.....24-58

HOLDERS
Grease Gun.....24-53

HOSE
Clamps, Plastic24-59
Grease Gun24-3, 24-52

Reels24-7

HYDRAULIC
Jack Oil24-35

INK
Marker24-27
Prussian Blue.....24-38
Stencil.....24-19
Toolmaker's24-18
Toolmaker's Remover24-18

KEYS
Machinery.....24-59
Woodruff.....24-58, 24-60

KEYSTOCK.....24-57-58

LAPPING
Compound.....24-36

LITHIUM GREASE.....24-17, 24-35-36, 24-50

LUBRICANTS
All 424-16
Anti-Seize24-35-36
Chain24-50
Creme24-49
Cutting Oil24-16, 24-48-49
Disc Brake24-35-36
Dry Film.....24-16
Dry Moly24-17-18, 24-35-36, 24-50
Food Grade24-17, 24-35-36, 24-50
Gear, Chain & Cable.....24-35-36
Graphite24-17
Greaseless24-49
High Temperature24-17, 24-35-36, 24-50
Industrial Strength24-49
Lithium24-17, 24-35-36, 24-50
Lubricating Oil24-16
Moly Chain24-17-18, 24-35-36, 24-50
Open Chain24-17
Open Gear24-17
Penetrating Oil.....24-16, 24-35-36, 24-50
Red Grease.....24-50
Rust Inhibitor.....24-19, 24-51
Silicone.....24-35-36
Stick.....24-49
Synthetic24-35-36
Tapping.....24-16
Wire Rope24-50

LUMBER
Crayons.....24-28

MACHINING COMPOUND.....24-36-37

MAINTENANCE SETS
Clevis Pins24-60
Cotter Pins24-58
Dowel Pins24-59
E-Clips.....24-58
Electrical Terminals24-59
Grease Fittings.....24-59
Hitch Pin Clips.....24-58
Housing Rings.....24-58
Machinery Keys.....24-59
Metric Grease Fittings.....24-60
Metric Roll Pins24-60
Metric Set Screws24-59
Metric Socket Head Cap Screws24-59
O-Rings24-59
Plastic Hose Clamps.....24-59
Retaining Rings.....24-58

Roll Pins24-58
Set Screws24-59
Snap Rings.....24-58
Socket Head Cap Screws24-59
Stainless Steel Woodruff Keys24-60
Taper Pins24-59
Woodruff Keys.....24-58

MARKERS
Ball Paint.....24-27
Chalk, Railroad.....24-27
Crayon, Lumber24-28
Fiber Tip24-27
Holders.....24-28
Ink24-27
Lumber Crayons.....24-28
Paint Sticks.....24-25-27
Pencils.....24-27
Spray24-18
Temperature Indicator24-29
Upside Down Paint.....24-18
Valve Action24-27

MASKING
Tape24-69

MOLD RELEASE
Epoxies24-20

MOLY
Lubricants24-17-18, 24-35-36, 24-50

MOPS
Handles24-23
Wet Mops24-23

MUSIC
Wire.....24-62

OIL
2-Cycle24-53
Absorbents24-53-57
Cutting.....24-16, 24-48-49
Dispensing Valves24-7
Gear Oil.....24-51
Hydraulic Jack.....24-35
Lubricating.....24-17
Open Chain24-17
Open Gear & Wire Rope.....24-17
Penetrating24-16, 24-35-36, 24-50
Sorbents24-53-57
Synthetic24-35-36
Transfer Pumps24-4-5, 24-7, 24-52

OIL SORBENTS
Blanket24-54
Booms24-55-56
Compact Spill Kit.....24-56
Floor Absorbent24-22, 24-54-55
Hazmat Spill Kit24-56-57
Spill Kit24-57
Pads24-53-55
Pans24-54
Particulate24-56
Peat Moss24-56
Pillows24-54, 24-56
Rolls24-53-55
Rugs24-54
Sheets24-54-56
Socks24-54, 24-56
Trucker's Spill Kit.....24-56
Wipes24-54

- continues -

SECTION 24
Maintenance, Repair & Operations

O-RINGS	24-59	PUMPS		SILICONE	
PACKING		Bearing Packer.....	24-4	Adhesives.....	24-34
Tape.....	24-68	Bucket.....	24-3-7	Flange Sealants.....	24-40
PADS		Dispenser.....	24-4	Gasket Maker.....	24-34
Sorbents.....	24-53-55	Grease.....	24-3-7	Grease.....	24-35-36, 24-50
PAINT		Loader.....	24-4-7	Lubricant.....	24-35-36
Aerosol.....	24-18	Transfer.....	24-4-5, 24-52	Mold Release.....	24-20
Ball Marker.....	24-27	PUTTY		RTV.....	24-34, 24-40, 24-47
Brushes.....	24-24	2000 Degrees.....	24-38	Sealants.....	24-34, 24-40, 24-47
Color Coding.....	24-18	Aluminum.....	24-32	SNAP	
Fluorescent.....	24-18	Stainless.....	24-32	Rings.....	24-58
High Temperature.....	24-18	Steel.....	24-32-33	SNOW	
Markers.....	24-25-27	Urethane.....	24-33	De-Icer.....	24-22
Primer.....	24-18, 24-30, 24-42	Wear Resistant.....	24-33	SOAPSTONE	
Remover.....	24-19	PVC		Holder.....	24-28
Rollers/Covers.....	24-24	Pipe Cement.....	24-29	Markers.....	24-27
Stencil Ink.....	24-19	RADIATOR		SOCKET	
Sticks.....	24-25-26	Cleaner.....	24-31	Cap Screw Kits.....	24-59
Stripper.....	24-31	REELS		SOCKS	
Touch Up.....	24-18	Hose.....	24-7	Sorbents.....	24-54, 24-56
Tray.....	24-24	REMOVER		SOLDER	
Upside Down.....	24-18	Paint.....	24-19	Flux.....	24-28
Valve Action.....	24-27	RETAINING		Paste.....	24-28
PARTS		Compound.....	24-41	SOLVENT	
Cleaner.....	24-31, 24-66	Rings.....	24-58	Cleaning and Degreasing.....	24-20
PASTE		RING		SPILL	
Brazing.....	24-28	Housing.....	24-58	Control.....	24-53-57
Soldering.....	24-28	Retaining.....	24-58	SQUEEGEES	24-23
Thread Sealant w/Teflon.....	24-28	ROLL		STENCIL	
PENCILS		Pins.....	24-58, 24-60	Ink.....	24-19
Carpenters.....	24-27	ROOF		Letters.....	24-15
PENETRATING		Brush.....	24-23	Numbers.....	24-15
Oil.....	24-16, 24-35-36, 24-50	RUBBER		Press.....	24-15
PILLOWS		Coating.....	24-32	STRAPPING	
Sorbents.....	24-54, 24-56	RUST		Tape.....	24-68
PINS		Inhibitors.....	24-19-21, 24-32, 24-35-36, 24-51, 24-69	STRETCH FILM	24-68
Clevis.....	24-60	SEALANTS		SWEEPING COMPOUNDS	24-22
Cotter.....	24-58	Adhesives.....	24-34, 24-46	SYNTHETIC	
Dowel.....	24-59	Anaerobic.....	24-39	Grease.....	24-35-36
Hitch.....	24-58	Anti-Seize.....	24-35-36	Oil.....	24-35-36
Roll.....	24-58, 24-60	Caulk.....	24-47	TAPER	
Taper.....	24-59	Flange.....	24-39-40	Pin Kits.....	24-59
PIPE		Foam.....	24-67	TAPES	
Flange Gasketing.....	24-39-40	Gasket.....	24-34, 24-39-40	Dispensers.....	24-68
How To Measure.....	24-15	High Temperature.....	24-34, 24-45	Double Face.....	24-68
PVC Cement.....	24-29	Pipe Flange.....	24-39-40	Duct.....	24-67
Teflon Tape.....	24-29, 24-69	Pipe Joint.....	24-29	Electrical.....	24-68
PIPE THREAD		Pipe Tape.....	24-29	Foam.....	24-68
Paste.....	24-28	Rubber.....	24-32	Foil.....	24-67
Repair Kits.....	24-38	Silicone.....	24-34, 24-40, 24-47	Masking.....	24-69
Tape.....	24-29, 24-69	Thread.....	24-28, 24-45-46	Packing.....	24-68
PLASTIC		Thread Locking.....	24-43-44	Pipe Sealing.....	24-29, 24-69
Cleaner.....	24-31, 24-47	Urethane.....	24-38	Strapping.....	24-68
Hose Clamps.....	24-59	SET		Teflon.....	24-29, 24-69
POLYETHYLENE		Screw Kit.....	24-59	TAPPING	
Stretch Film.....	24-68	SHAFT ALIGNMENT SYSTEMS	24-1	Lubricants.....	24-16
PRUSSIAN BLUE INK	24-38	SHIM		TEFLON	
		Brass.....	24-63	Tapes.....	24-29, 24-69
		Slotted.....	24-63	TEMPERATURE	
		Steel.....	24-62	Indicator.....	24-29

– continues –

SECTION INDEX

SECTION 24
Maintenance, Repair & Operations

TERMINALS		VARNISH	
Kits	24-59	Remover	24-31
THICKNESS FEELER GAGE	24-60-61	VINYL	
THREAD		Coating	24-19
Locker	24-43-44	WASP AND HORNET SPRAY	24-20
Repair	24-38	WEARING COMPOUND	24-37-38
Sealants	24-28, 24-45-46	WELDERS ANTI-SPLATTER	24-21
Sealing	24-45-46	WIRE	
TOOLMAKER'S		Music	24-62
Ink	24-18	Scratch Brushes	24-24
Ink Remover	24-18	Stainless	24-62
TRANSFER		WIRE ROPE	
Pumps	24-4-5, 24-7, 24-52	Lubricant	24-50
URETHANE		WOODRUFF	
Repair Kits	24-33	Keys	24-58, 24-60
Sealants	24-38		
VALVES, DISPENSING	24-7		

AccuShim Inc./Alemite™

AccuShim Inc.

The V180 Precision Laser Shaft Alignment System

Fast, Easy, Precise.
Your Complete Alignment Needs Right out of the Box!!!

Bringing precision laser alignment to every facility with rotating equipment.

The system is based on dial indicator methods, which have been used for years. The V180 system, however, eliminates the need for cumbersome bracket set-up of dial indicators, bracket sag considerations, and brings laser accuracy to every alignment job. Since the V180 displays actual machine values right on-screen, live, the user isn't required to perform any complicated calculations. You can spend your time performing precision alignments, not re-training or remembering equations.

User-friendly display unit: Figures, numbers, and logical symbols guide the user towards a perfect alignment. The system is operated by four keys using symbols that are universally understood.

Advanced laser technology: There are two combination transmitter-detector units, each containing a laser transmitter and a high quality 10 mm laser detector. The laser detectors measure the travel of the laser beam as the shafts are rotated. These movements of the laser beam over the detectors represent the misalignment of the shafts.

"What you do is what you see" operation: The alignment data is continuously updated. All movements of the motor are simultaneously displayed with a resolution of 0.0001". As you shim or move the machine the values update to let you know exactly where you are each step of the way. This means no more guessing about the shim amount, or how much to move a machine. The V180 also determines and locates a "soft foot" condition right on the screen.

With the V180 laser alignment system there is no interpreting of the values as with dial indicators the position-sensitive detectors precisely measure the misalignment. The large LCD display clearly presents the position of the machinery being aligned.

Technical Specifications Transmitter/Detector Unit

Housing material	Composite
Laser class	2
Laser wavelength	675 nm, visible red
Detector area	10 x 10 mm
Displayed resolution	0.0001"
Measuring distance	1 meter
Light stabilization	No interference from ambient light

Display Unit

Housing material	Composite
Displayed accuracy	+/- 2%
Display	Custom LCD (77 x 33 mm)
Power supply	(3) "C" alkaline batteries
Weight	8 lb. (4kg)

"LS - 3"™ V180 Accessories

Part Number	Description
VCH - 35	35" LONG extension chain
VRF - 5	Short ROD 5" x 12mm (Tapped)
VRF - 12	Tall ROD 12" x 12 mm (Tapped)
VHA - 1	Thin MAGNETIC FIXTURES (1/2" wide)

Specifications of the V180 with Standard Fixtures...

Shaft Diameters: 1/8" – 7.5"
(Increased to 20" with optional VCH-35)

Rod Height above coupling/shaft: 8.5"
(Can be decreased to 5" with optional VRF-5 short rod or increased to 12" with optional VRF-12 long rod. For increased height, all the rods connect to one another for unlimited height).

Width of Mounting Brackets: 7/8"
(Can be decreased to 1/2" by using the optional Thin Magnetic Fixtures).



Alemite™

MRO LUBRICATION SUPPLIES

Grease Guns:

Economy Grease Gun Part No: 404

Develops up to 10,000 psi. 2-way loading: cartridge or suction fill. One-piece metal head construction. Delivery: 1 oz. Per 21 strokes. Poly-bag packaging.



Grease Gun 404

Heavy Duty Grease Gun

Develops up to 10,000 psi. Automatic variable stroke/pressure. Delivery: 1 oz. Per 21 strokes. 3-way loading: cartridge, suction fill or bulk. Heavy-duty one-piece head. Has bleeder valve, vinyl grip, deluxe pull handle, and positive lever stop. Loader fitting included. Deluxe packaging.



Grease Gun 500

Part No: 500 Gun with rigid extension and coupler.
Part No: 500-L Gun with 24 oz. Cylinder and rigid extension and coupler.
Part No: 500-E Gun with 18" hose and coupler.

Heavy Duty Grease Gun

Part No: 525
Develops up to 4,500 psi. Automatic variable stroke/pressure. Delivery: 1 oz. Per 33 strokes. Heavy-duty one-piece head. Has bleeder valve, vinyl grip and deluxe pull handle. 3-way loading: cartridge, suction fill or bulk. Loader fitting included. Deluxe packaging.



Grease Gun 525

Heavy Duty Grease Gun

Part No: 550
Develops up to 4,500 psi. Automatic variable stroke/pressure. Delivery: 1 oz. Per 33 strokes. 3-way loading: cartridge, suction fill or bulk. Heavy-duty one-piece head. Has bleeder valve, vinyl grip, and deluxe pull handle. Loader fitting included. Deluxe packaging.



Grease Gun 550

Note: Above guns are 16 oz. Bulk capacity or accept a 14 oz. Cartridge unless otherwise noted.

Extra Heavy Duty Grease Gun Volume Gun

Develops up to 1,800 psi.
Delivery: 1 oz. Per 7 strokes. 3-way loading: cartridge, suction fill or bulk. Heavy-duty one-piece head. Has deluxe pull handle, heavy-duty rivets, heavy-duty lever with positive stop, clean-out check and vinyl grip. Includes loader fitting and rigid extension with coupler.



4015-A4

4015-B4

Part No: 4015-A4, 16 oz.
Part No: 4015-B4, 24 oz.

Maintenance, Repair & Operations

Alemite™

Extra Heavy Duty Grease Gun - 10,000 psi

For all pressure gun lubricants. 3-way loading: cartridge, suction fill or bulk. Equipped with loader fitting. Gun outlet: 1/8" NPTF(f).

Part No: 1056-S4 – 16 oz. High pressure gun. Pressure: 10,000 psi. Delivery: 1 oz. Per 36 strokes.

Part No: 1056-SE4 – 16 oz. Model 1056-S4 with rigid extension and coupler.

Part No: 1056-LE4 – 24 oz. With rigid extension and coupler.

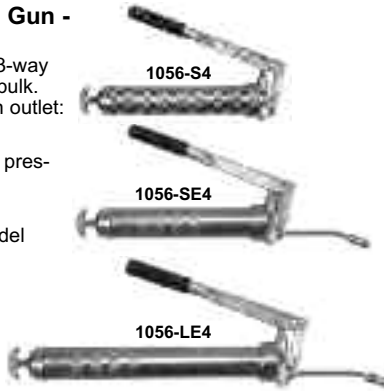

Severe Duty Grease Gun - 10,000 psi

High-pressure gun. Delivers 1 oz. Per 20 strokes. 24 oz. Capacity. Extremely rugged gun for severe operating conditions. Combination spring and vacuum priming. Extra long solid lever for maximum leverage. Built in check valve. Heavy steel linkage with replaceable pins. Zinc plated. Gun outlet: 1/4" NPTF(f).

Part No: 6243-J3 Gun only.

Part No: 6243-J3E Gun with rigid extension (54269) and coupler.

Part No: 54269 Rigid Extension Kit includes 6304-B Coupler.

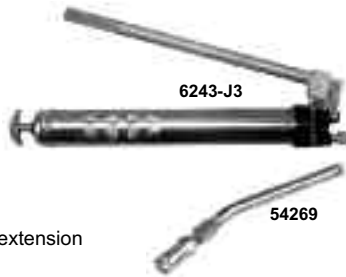

Severe Duty Grease Gun - 5,000 psi

Volume gun. Delivers 1 oz. Per 10 strokes. 24 oz. Capacity. For all pressure gun lubricants. Extremely rugged gun for severe operating conditions. Combination spring and vacuum priming. Extra long solid lever for maximum leverage. Built in check valve. Heavy steel linkage with replaceable pins. Zinc plated. Gun outlet: 1/4" NPTF(f).

Part No: 6679-J3 Gun only.

Part No: 6679-J3E Gun with rigid extension and coupler assembly (54269).

Part No: 54269 Rigid Extension Kit includes 6304-B Coupler.



Extreme Pressure Grease Gun - 15,000 psi

Part No: 6268-2

For bulk or 1-1/2" diameter stick lubricant. For lubricated valves and other high-pressure applications. Develops up to 15,000 psi. Screw prime with spring-loaded feeder provides 20 or more strokes without reprime. 12 oz. Capacity. Delivers 1 oz. Per 24 strokes. Zinc plated. With loader fitting 322610. Gun outlet: 1/4" NPTF(f).

Part No: 325540-1

For giant button head couplings. Consists of model 6268-2 gun, relief valve 319700, button head coupler 319702, swivel 52750, swivel 52752, high pressure "T" 309727, gauge 317150, hose assembly 317875-1F and adapter 327033. Includes carrying strap.

Part No: 325540-2

For high pressure oil field fittings. Same as above except Saf-T-Vent™ coupling 310428 replaces valve 319700 and coupler 319702. Includes carrying strap.



Mini Gun

Part No: 4046-A

For all types of pressure gun lubricants. Uses standard 3-1/2 oz. Lubricant cartridges. Small, fits everywhere. Durable construction withstands hard use. Includes one grease cartridge.

Replacement cartridges B408 (3-pack)



Push-Type Grease Guns For Hydraulic And Flush-Type Fittings

Simple thrust action. Internal spring returns handle to original position. 9 oz. Capacity. Zinc plated. Develops up to 4,200 psi. Fast volume delivery. Includes loader fitting.

Part No: 7584 Includes hydraulic coupler 308730.

Part No: 7584-F Includes Z 737 flush-type nozzle.

Part No: 7584-Z Includes Z 334 push-type nozzle.



Screw-Type Grease Gun

Part No: C-600

For all types of pressure gun lubricants. Operates by turning screw handle. Remove head to fill. 8 oz. Capacity. Requires rigid extension or flexible hose assembly to be ordered separately. Gun outlet: 1/8" NPTF(f).



Suction Gun

Part No: 420

For draining and refilling brake master cylinders, differentials, oil filters, gear cases, etc. 16 oz. Capacity. Includes flexible suction hose. Gun outlet: 1/4" NPTF(f).



Heavy Duty Lever-type Oil Gun

Part No: 4035

For fluid lubrication of bearings, hydraulic movement of slides in machinery, lubrication in tap and die use, precharging of hydraulic cylinders and volume filling of fluid reservoirs. 26 oz. reservoir capacity. Volume delivery of product (.15 oz. Per stroke). Develops up to 1,800 psi.



Extensions:

Rigid Extensions For Grease Guns

Various lengths permit ease of attachment to hydraulic fittings. Hydraulic coupler ends are triple-jaw type for a superior seal. Slight pushing action snaps jaws onto fittings. Permits wide 35° leak-proof sealing angle Ends are 1/8" NPTF(m).

Model No.	Overall Length (in)	Coupler Number	Extension Only
6279	18	6304-B	307436
B6638#	6-3/4	6304-B	53986
B6638-A#	6-5/8	308730	53986
6638-B	12-1/8	308730	319411
54269*	8	6304-B	54821

#indicates blister pack
*Extension 1/4" NPTF



24
Maintenance
Repair
Operations

Alemite™

Grease Gun Extension Hose

WARNING: For use with hand operated grease guns only.
Economical and durable hose. 12,000 psi burst pressure.
1/8" NPTF(m) ends.

Model No.	Length (in)	Working Pressure	Hose Type
337595-A1	12	6,000 psi	Thermoplastic
B-337595-B1	18	6,000 psi	Thermoplastic
B-337595-A1	12	6,000 psi	Thermoplastic
*B-317850-1	12	4,800 psi	Elastomeric
*317850-1F	18	4,800 psi	Elastomeric
*317850-2	24	4,800 psi	Elastomeric
*317850-3	36	4,800 psi	Elastomeric

*Single wire braid hose.



Grease Gun Hose Assemblies:

For hydraulic fittings. End connections are 1/8" NPTF(m). Maximum working pressure is 4,800 psi and minimum burst pressure is 12,000 psi.

For Hydraulic Fittings:

Model No.	Length (in)	Coupler	Hose
B6703-A	12	308730	317850-1
6703-B	18	308730	317850-1F
B6652-A#	12	6304-B	317850-1
6654-A	18	6304-B	317850-1F

#Indicates Blister Pack



For Pin-type Fittings:

Model No.	Length (in)	Coupler	Hose
A-908-A	12	VB-942	317850-1



For Standard Button Head Fittings:

Model No.	Length (in)	Coupler	Hose	Swivel
7089	12	42030-A	317850-1	301980



For Giant Button Head Fittings:

Model No.	Length (in)	Coupler	Hose	Swivel
6704-A	12	304300-A	317850-1	301980
6704-B	18	304300-A	317850-1F	301980



WARNING: The pressure rating on these hose assemblies applies when used with hand operated grease pumping equipment ONLY, such as grease guns or bucket pumps. DO NOT use with power operated equipment. Rupture of the hose can result in serious injury such as fluid injection into the flesh. For powered equipment refer to adapters and swivel devices on pages 46 and 47 of this catalog, which can be safely used where rapid pressure rises are encountered.

Manual Pumps:

15,000 psi High Pressure Bucket Pump

Part No: 6713-4
30 lb. bulk capacity. Delivers 1/16 oz. Per stroke. Equipped with dynamic primer and manually operated pressure relief valve. Pump outlet is 1/4" NPTF(f). Order hose separately.
Part No: 314898 optional follower plate.



Foot Operated Pump

Part No: 6299-J4
For all pressure gun lubricants. Capacity: 25 lbs. Delivery 1/8 oz. Per stroke. Equipped with air relief valve, hose hanger, lubricant strainer and follower plate. Easily operated foot-pedal linkage. Outlet: 1/4" NPTF(f). Order hose assembly separately. 8,000 psi.



Lubricators-3,500 psi Models

Part No: 7531-4
For all pressure gun lubricants. Equipped with 5' hose and coupler assembly 322434. Pump outlet: 3/8" NPTF(f). For 35 lb. pail. Furnished with flexible follower plate 337665.



Volume Delivery Bucket Pump-500 psi

Part No: 7181-4
For all oils and pressure gun lubricants. Equipped with 25 lb. capacity container. Adjustable leverage adapts pump to lubricant and operating conditions. Pump outlet: 3/8" NPTF(f).
7181-K includes hose 317807-5F and curved nozzle 306610.
7181-M includes 3631 meter, hose 317807-5F and curved nozzle 306610.



Bucket Pumps:

Multi-Pressure Bucket Pumps

Variable pressure 2,500 to 5,000 psi for 35 lb. capacity (or 5 gallons). Adjustable for all pressure gun lubricants. Adjustable leverage (three choices) adapts pump to all lubricant and operating conditions.

Model No.	Includes Hose Assy.	Hose Length (ft)	Coupler Type
7149-4	-	-	-
7149-A4	322434	5	Hydraulic (narrow)
7149-C4	6617-G	5-1/2	Hydraulic
7149-D4	**	5-1/2	Pin-type
7149-E4	6616-G	5-1/2	Standard button head
7149-F4	6615-G	5-1/2	Giant button head
7149-H4*	322434	5	Hydraulic (narrow)

*Includes gun loader kit 322630.
**Includes 317854-5F hose, 50491 coupler and A336 fitting.
7149-T is 7149-4 plus 6777-5 Porta-Cart
7149-V is 7149-C4 plus 6777-5 Porta-Cart



Cart:

Porta-Cart

Part No: 6777-5
Used with 6713, 7181 and 7149 series pumps. Speeds lubrication service where machines are widely separated. Reduces operator fatigue. Overall width: 18".

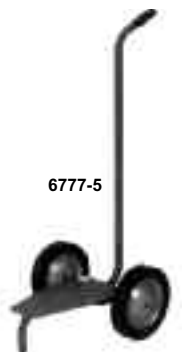

24 Maintenance Repair Operations

Maintenance, Repair & Operations

Alemite™

Hoses for Manual Pumps

WARNING: For use with manually operated equipment only. Single wire braid hose construction.

Model No.	Coupling Thread Size (in)	Hose ID (in)	Max Work Pressure
317853-5	1/8 NPTF(m) x 3/8 NPTF(m)	1/4	4,400 psi
317854-5F	3/8 NPTF(m) x 3/8 NPTF(f)	3/8	3,200 psi
317854-10	3/8 NPTF(m) x 3/8 NPTF(f)	3/8	3,200 psi

Hose for bucket pumps.

Hose Assemblies for Hydraulic Fittings

Model No.	Length (ft)	Coupler	Hose
6617-G	5-1/2	6304-C	317854-5F
6617-K	10	6304-C	317854-10
322434	5	308730-A	317853-5



Hose Assemblies for High Pressure Bucket Pumps

Part No: 6616-G
For standard button head fittings. Equipped with built-in check valve. Includes 51219 swivel, 317854-5F hose, 42030 coupler and 46405 valve.

Part No: 6615-G
For giant button head fittings. Equipped with built-in check valve. Includes 51219 swivel, 317854-5F hose, 304300 coupler and 46405 valve.



WARNING: The pressure rating on these hose assemblies apply when used with hand operated grease pumping equipment ONLY, such as grease guns or bucket pumps. DO NOT use with power operated equipment. Rupture of the hose can result in serious injury such as fluid injection into the flesh. For powered equipment refer to adapters and swivel devices, which can be used safely where rapid pressure rises are encountered.

Wheel Bearing Packers:

Drum Mounted

Combination pump and wheel bearing packer. Repacks all types of wheel bearings from 19/32" ID to 8" OD. All models include follower plate and drum cover. Units attach to original containers. 35 lb. model includes carrying handle.

Part No: 6709-A4 for 120 lb. drums
Part No: 6709-B4 for 35 lb. pails



Bench Top Model

Removes old grease from race and cage of roller and ball type bearings and repacks them with fresh lubricant. Handles all bearings from 3/4" ID to 6" OD. Cover keeps unit clean when not in use. Mounting holes for attachment to bench. Use with hand gun or power pump.

Part No: 6598-B



Volume Delivery Loader Pumps

For grease guns with Alemite loader fitting. Delivery: 1 lb. per 6 strokes. Includes 317219 loader extension.

Part No: 7537-4

For 35 lb. pail. Equipped with cover and flexible follower.

Part No: 7538-4

For 120 lb. drum. Equipped with cover and flexible follower 338802.

Part No: 7539-4

For 400 lb. drum. For mounting on full open drum, order drum cover 318040-4 and follower 338923.



Economy Loader Pump

Part No: 7118-1

For all pressure gun lubricants. Fits 25 and 35 lb. pails. For loading hand guns equipped with Alemite loader fitting. Includes follower plate, loader coupler, and drum cover.



Loader Fittings

For grease guns with 1/8" NPTF(f) port in head, remove plug and install.

Part No: B306740

For light and medium lubricants. Medium ball check passage. One piece construction.

Part No: B322610

For heavy lubricants. Large ball check passage. Two piece construction.



Loader Coupler

Part No: 306741

For installation on loader pumps. Used in conjunction with loader fittings B306740 and B322610. Thread: 3/8" NPTF(m).



Dual Leverage Dispensers

For fluid gear lubricants. Attach directly onto original containers. Delivery: standard leverage 1 pint per 6 strokes. 317809-5F 5-1/2" hose with 306610 curved nozzle. Pump outlet: 1/2" NPTF(f).

Part No: 7533-4 for 5 gallon pail. Pail cover included.

Part No: 7534-4 for 16 gallon drum. Drum cover included.

Part No: 7535-4 for 55 gallon drum. 2" NPTF(m) bung adapter included.



Economy Dispenser

Part No: 7117-1

For all fluid lubricants. Fits on 25 and 35 lb. pails. Delivery: 2.6 oz. per stroke. All-steel construction. Unit includes 5' hose assembly with curved nozzle and a pail cover assembly.



Standard Transfer Pump

Part No: 6796

For fluid lubricants, solvents, thinners, automotive additives, chemicals, and non-corrosive liquids. Delivery: 3/4 pint per stroke. 2" NPTF(m) thread on die cast base fits all standard bungs. Pump rotates in base. Self-adjusting, telescoping suction tube fits all drums. Floating check valve allows liquids to drain back from pump when not in use.



Alemite™

Diaphragm Transfer Pump

Part No: 6797

Handles an extensive variety of petroleum products for industry, farm, or construction. Delivery: 20 gallons per 100 strokes. Self-venting. Adjustable bung adapter allows adjustment of pump to any radial position. Made of heavy duty cast aluminum. Built-in strainer and vacuum breaker. Fits 16 and 55 gallon containers.



Needle Nose Adapter

Part No: B6783#

For use in all universal joints and lubrication tight spots. Consists of contact nozzle and locking sleeve. Length: 5".



Rigid/Flexible Extension

Part No: 6778

Can be bent around obstructions or made rigid for one hand lubrication. Meets safety requirements for use with air-operated lubrication equipment. Hose max working pressure: 20,000 psi. Overall length: 13-1/2". 1/8" NPTF(m) for use with all high pressure control valves.

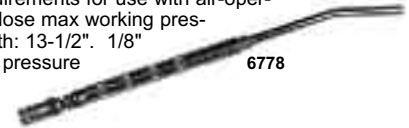

Swivels

Permit easy handling of control valves and prevent damage to hose from twisting. Ball bearing construction.



Straight	90°	Z-type	Thread (m) x (m)	Psi Rating
B52750#	B52751#	B52752#	1/4" NPTF x 1/2"-27*	10,000
54730	-	54732	1/8" NPTF x 1/8" NPTF	10,000
B321320#	-	B331107	1/4" NPTF x 1/4" NPTF	10,000
332912	-	-	1/2" NPTF x 1/2" NPTF	7,000

*NS taper #Indicates blister pack.

90° Angle Adapter

Part No: B6238#

Angle adapter specially made for compact, subcompact, and K-cars. Ideal for working in tight areas.



Needle Adapter

Part No: B6785#

Ideal for working on compact and subcompact automobiles.

#Indicates blister pack.



Adapters:

Injector Needle

Part No: B336770#

Snaps into all standard grease couplers. Permits greasing of sealed bearings and CV joints. Comes with plastic needle cover to protect when not in use.

#Indicates blister pack.



Swivel Adapter

Part No: B6278#

Consists of swivel hydraulic coupler 6509-D, locking sleeve, and extension. Length: 8".



Flexible Extension Adapter

Part No: 6248-1

Consists of locking sleeve, wire braid hose/metal guard assembly and hydraulic coupler 6304-B. Max working pressure: 3,000 psi. Length: 11-1/2".



Hydraulic Push-Type Adapter

Part No: B6239#

Adds extra length to control valve. Consists of push-type contact nozzle and locking sleeve. Length: 6".



Extra Length Adapter

Part No: 6279

Coupler mounted at 15° angle. Consists of hydraulic coupler 6304-B and locking sleeve plus extension. Length: 21".

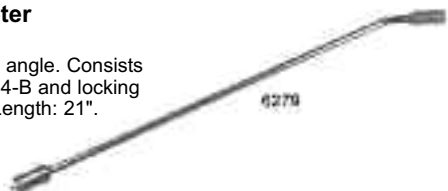

GREASE PUMPS AND ACCESSORIES

Standard Duty:

High Pressure Standard Duty Pumps (Stationary)

Recommended for piped installations of moderate length. Easily handles fibrous multi-purpose chassis lubricants. Equipped with air connector and quick detach air coupler. The 8540 series models have a 3" diameter air motor and the 8550 series models have a 2-7/16" diameter air motor. Air inlet 1/4" female pipe thread. Material outlet 3/8" female pipe thread.

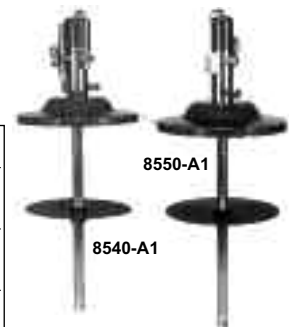

Model No.	Drum Size (lbs)	Pump Ratio	Approx. Del/Min#	Ship Wt. (lbs)
8540-A1*	120	70:1	2.25	35
8540-B	120	70:1	2.25	32
8549-B1+	400	70:1	2.25	35
8550-A1*	120	50:1	2.50	35
8559-B+*	400	50:1	2.50	35
331571-A5	120	26:1	5.25	34
331571-B5	400	26:1	5.25	44
331571-C5	35	26:1	5.25	29

Model No.	Air Hose	Mat'l Hose	Follower No.	Cover No.	Union No.
8540-A1*	317803-3	317876-5	338802@	338371	321155
8540-B	317803-3	317876-5	338802@	338371	321155
8549-B1+	317803-3	317876-5	338911@	318040-4	321155
8550-A1*	317803-3	317876-5	338802@	338371	321155
8559-B+*	317803-3	317876-5	338911@	318040-4	321155
331571-A5	317803-3	317875-25	338802	338371	321155
331571-B5	317803-3	317875-25	338911	318040-4†	321155
331571-C5	317803-3	317875-25	338825	338166	321155

Bold indicates included with pump model.

@Follower is flexible - works with straight or tapered drum.

#Free delivery NLGI # 1 at 77° F, 150 psi pump operating air pressure.

+Includes bung adapter model 326750.

*Equipped with Pressuretrol 319800-1.

†Bung adapter 326750 required to mount pump to cover.

Note: The 331571 series high-pressure pumps are designed to deliver light to medium viscosity non-fibrous lubricants, rust-proofing compounds and semi-solid fluids. All of these products are delivered directly from their original containers.

Maintenance, Repair & Operations

Alemite™

High Pressure PML Pumps (Stationary)

These pumps feature the exclusive Alemite PML air motor for quiet operation and quick serviceability. Recommended for piped installations of moderate length. Easily handles fibrous multipurpose chassis lubricants. Equipped with air connector and quick detach air coupler. Air motor is 3" diameter. Air inlet 1/4" female pipe thread. Material outlet 3/8" female pipe thread.



Model No.	Drum Size (lbs)	Pump Ratio	Approx. Del/Min#	Air Hose	Mat'l Hose	Follower No.	Cover No.	Union No.	Ship Wt. (lbs)
9640	120	70:1	3.25	317803-3	317876-5	338802@	338371	321155	30
9649	400	70:1	3.25	317803-3	317876-5	338911@	338163	321155	27
9650	120	50:1	3.00	317803-3	317876-5	338801@	338371	321155	17
9650-A	120	50:1	3.00	317803-3	317876-5	338801@	338371	321155	28
9679	400	50:1	4.50	317803-3	317876-5	338911@	338163	321155	24
9679-A	400	50:1	4.50	317803-3	317876-5	338911@	338163	321155	49

Bold print indicates included with model.
@Follower is flexible - works with straight or tapered drum.
#Free delivery NLGI # 1 at 77° F, 150 psi pump operating air pressure.

High Pressure Intermediate Duty Pump (Stationary) - PML

Ratio 50:1

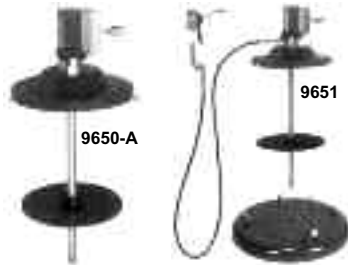

Model No.	Drum Size (lbs)	Pump Ratio	Approx. Del/Min#	Air Hose	Mat'l Hose	Follower No.	Cover No.	Union No.	Ship Wt.
9650	120	50:1	3	317803-3	317876-5	338801@	338371	321155	17
9650-A	120	50:1	3	317803-3	317876-5	338801@	338371	321155	28
9651	120	50:1	2	44734	317875-7	338801	6320-3	B52752	45
9651-T	120	50:1	2	44734	317875-7	338801	6320-3	B52752	45
9651-S	120	50:1	2	44734	317875-7	338801	6320-3	B52752	45

Bold indicates included with model.
@Follower is flexible - works with straight or tapered drum.
Note: 9651 includes dolly 316315-5 and 9651-T includes hand truck 338958.
9651-S has no dolly or hand truck.
#Free delivery NLGI # 2 at 77° F, 150 psi pump operating air pressure.

High Pressure Heavy Duty Pumps (Stationary)

These pumps are built for continuous operation. They are recommended for longer piped installations. These double-acting pumps will provide consistent, reliable delivery of hard to pump lubricants up to NLGI #3, direct from original drums or bulk containers. An air connector and quick detach air coupler are included with all models. All models have a 4-1/4" air motor except 7795-A5 and 7795-B5 which have 6" air motors. Air inlet and material outlet are 1/2" female pipe thread. Air outlet is 3/4" female pipe thread.



Model No.	Drum Size (lbs)	Pump Ratio	Approx. Del/Min#	Ship Wt.
7784-A4	400	25:1	32	76
7785-A5	400	40:1	22	77
7785-B5	120	40:1	22	72
7786-A5	400	75:1	12	75
7786-C	120	75:1	12	75
7795-A5	400	80:1	13	90
7795-B5	120	80:1	13	84

Model No.	Air Hose	Mat'l Hose	Follower No.	Cover No.	Union No.	Bung Adapter	Muffler
7784-A4	317811-5	317882-7	338912@	323847-4	321155	326750-B1	324170
7785-A5	317811-5	317882-7	338912@	323847-4	321155	326750-B1	324170
7785-B5	317811-5	317882-7	338804@	323800-4	321155	326750-B1	324170
7786-A5	317811-5	317882-7	338912@	323847-4	321155	326750-B1	324170
7786-C	317811-5	317882-7	338804@	323800-4	321155	326750-B1	324170
7795-A5	317811-5	317882-7	338912@	323847-4	321155	326750-B1	324170
7795-B5	317811-5	317882-7	338804@	323800-4	321155	326750-B1	324170

@Follower is flexible - works with straight or tapered drum.
#Free delivery NLGI # 2 at 77° F, 150 psi pump operating air pressure.

Medium Pressure Grease Pump 26:1 Ratio

Air operated unit designed to handle heavy oils and light greases. Used in a variety of agricultural and industrial equipment applications.

Model No.	Container Size (lbs)	Pump Ratio	Mat'l Hose	Swivel No.	Control Handle	Cover
8553-2	35	26:1	317875-25	B52752	6320-3	388166

Bold indicates included with model.



Portable High Pressure PML Pumps

These air powered mobile units feature the exclusive Alemite PML air motor for quiet operation and quick serviceability. Models include cover mounted pump, follower, 7' delivery hose, Z-swivel, control handle. All models include a built-in control handle on the cover. All models have a 3" diameter air motor. Air inlet is 1/4" female pipe thread (connector and quick detach coupler included). Material outlet is 3/8" female. Drum not included.



Model No.	Drum Size (lbs)	Pump Ratio	Approx. Del/Min#	Mat'l Hose	Follower No.	Swivel No.	Control Handle	Dolly	Ship Wt. (lbs)
9611+	-	50:1	2	-	-	-	-	-	12
9611-A	**	50:1	2	44734	317875-7	‡	B52752	6320-3	393629
9611-H	35	50:1	2	44734	317875-7	337665	B52752	6320-3	21
9611-B	**	50:1	2	44734	317875-7	‡	B52752	6320-3	46
9611-Z	35	50:1	2	44734	317875-7	337665	B52752	6320-3	338958

Bold indicates included with model.

@Follower is flexible - works with straight or tapered drum.
Free delivery NLGI # 2 at 77° F, 150 psi pump operating air pressure.
+ Complete replacement pump and downtube for model 9611-H order for replacement only.
‡ 337665 is for use with a 35 lb. container. 338801 is used with included container.
** Note: Model 9611-A will hold 70 lbs. bulk grease or 35 lbs. original refinery pail.

24
Maintenance
Repair
Operations

Alemite™

Multi-pressure Bucket Pumps

Variable pressure 2,500 to 5,000 psi for 35 lb. capacity (or 5 gallons). Adjustable for all pressure gun lubricants. Adjustable leverage (three choices) adapts pump to all lubricant and operating conditions.



Model No.	Container Size (gal)	Approx. Del (oz/stroke)	Mat'l Hose	Hose Length (ft)	Coupler Type	Dolly	Ship Wt. (lbs)
7149-A	5	1/3	-	-	-	6777-5	21
7149-A4	5	1/3	322434	5	Narrow hyd.	6777-5	22
7149-C4	5	1/3	6617-GXX	5-1/2	Hyd.	6777-5	22
7149-D4	5	1/3	-	5-1/2	Pin type	6777-5	22
7149-E4	5	1/3	6616-G	5-1/2	Std. Button	6777-5	22
7149-F4	5	1/3	6615-G	5-1/2	Giant button head	6777-5	22
7149-H4 X	5	1/3	322434	5	Narrow hyd.	6777-5	22
7149-T	5	1/3	-	-	-	6777-5	48
7149-V	5	1/3	6617-G	5-1/2	Hyd.	6777-5	48

Bold indicates included with model.

X Includes Gun Loader Kit, model number 322630 - XX Includes: 317854-5F, 50491, A336

Hose Reels:



Heavy Duty

Model No.	Bare Reel	Max Pressure	Delivery Hose	Connecting Hose	Union	Hose Stop	Swivel	Ship Wt.
8078-A	7334-B	6,000 psi	317874-30	317876-2	1001-86	337437	331107	56
8078-B	7334-B	6,000 psi	317874-50	317876-2	1001-86	337437	331107	59

Bold indicates included with model.

Note: Inlets are 1/2" NPTF(f) and Outlets are 3/8" NPTF(f) for both models.

Severe Duty

Model No.	Bare Reel	Max Pressure	Delivery Hose	Connecting Hose	Union	Hose Stop	Swivel	Ship Wt.
8078-G	7334-C	6,000 psi	317874-50	317876-2	1001-86	337437	331107	61

Bold indicates included with model.

Note: Inlets are 1/2" NPTF(f) and Outlets are 3/8" NPTF(f).

Extra Heavy Duty

Model No.	Bare Reel	Max Pressure	Delivery Hose	Connecting Hose	Union	Hose Stop	Swivel	Ship Wt.
8076-A	7232-B	6,000 psi	317870-50	317882-2	1001-86	337437	331107	75
8076-B	7232-C	6,000 psi	317870-70	317882-2	1001-86	337437	331107	75

Bold indicates included with model.

Note: Inlets are 1/2" NPTF(f) and Outlets are 3/8" NPTF(f) for both models.

WARNING: Mount reels no higher than 20 feet from floor on overhead mounting.

Dispensing Valves:

Standard Control Valve

Part No: 6320-3

Delivers pre-set, measured shots with trigger partially depressed. Provides continuous flow with trigger fully depressed. Includes 6-1/2" hydraulic extension and hydraulic coupler 6304-B. Control Valve inlet: 1/4" NPTF(f). The control valve is designed for high pressure applications (up to 7,500 psi).



Volume Valve

Part No: 6438

For medium-pressure, high-volume lubrication. Does not engage fitting directly. Uses whip-end hose for connection. Inlet: 3/8" NPTF(f). Outlet: 1/4" NPTF(f). The control valve is designed for high pressure applications (up to 6,000 psi).



- continues -

Dispensing Valves (continued)

Deluxe Control Valves

Part No: 7421-3

Selector provides full flow, wide range of measured shots. Built-in three-stage strainer prevents dirt from fouling valve or damaging bearings. Includes 6-1/2" hydraulic extension and hydraulic coupler 6304-B. Control valve inlet: 1/4" NPTF(f). The control valve is designed for high pressure applications (up to 7,500 psi).



Part No: 7421-A3

Model 7421-3 includes a high-low converter 6067-1.

Model No.	Measured Shot	Material Inlet (in)	Material Outlet (in)	Extension	Coupler	High-Low Converter
6320-3	Preset	1/4 NPTF(f)	1/8" NPTF(f)	49136	6304-B	-
6438	-	3/8 NPTF(f)	1/4" NPTF(f)	-	-	-
7421-3	Adjustable	1/4 NPTF(f)	1/8" NPTF(f)	49136	6304-B	-
7421-A3	Adjustable	1/4 NPTF(f)	1/8" NPTF(f)	49136	6304-B	6067-1

Bold indicates includes a high-low converter 6067-1.

Accessories: "Hi-Lo" Converter

This model is used as an in-line pressure reducer for high-pressure lubricant applications. The model has a two-position setting, which allows the user to maintain normal system pressure when set in the "Hi" position. When the unit is set in the "Lo" setting, system pressure is reduced to 10% of the system pressure entering the unit. Designed for use to prevent "blowing-out" of seals. 1/8" NPTF(f) inlet/outlet allows the unit to be installed in most in-line applications. **Part No: 6067-1**

OIL PUMPS AND ACCESSORIES

Hand Operated Medium Pressure Fluid Pumps

Hand-operated pumps provide economical and convenient dispensing when air operated units are not practical. Models available to dispense fluids with viscosity up to SAE 140. These pumps are ideal for farm, construction, or industry use. The model 6796 is an economical barrel pump for light fluids. The model 6797 is UL Listed and comes equipped with a static wire hose, it is an ideal pump for diesel fuel and light oils. Models 7534-4 and 8570-5 are for use with gear lube; model 8571-5 is for use with ATF and includes filter.

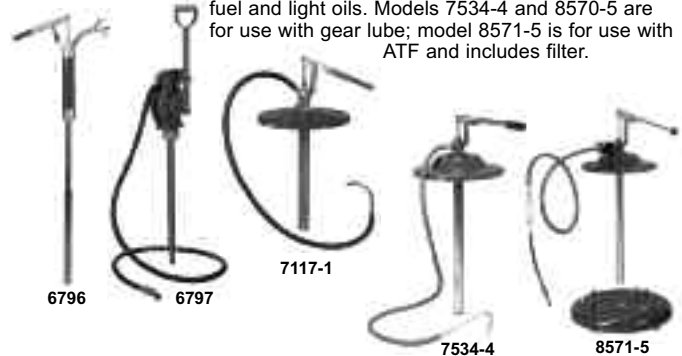

Model No.	Drum Size (gal)	Approx. del.	Mat'l Hose Lgth (ft)	Bung Adapter	Cover No.	Meter No.	Dispense Nozzle	Dolly	Ship. Wt. (lbs)
6796	16-55	3/4 pt/ stroke	N/A	Integral	-	-	-	-	6
6797	16-55	20 gal/ 100 strokes	8	Integral	-	-	-	-	13
7117-1	5	2.6 oz/ stroke	5	-	-	-	-	336575-A1	8
7533-4	5	1 pt/ 6 strokes	5-1/2	-	337729	-	306610	336575-A1	13
7534-4	16	1 pt/ 6 strokes	5-1/2	-	328245-4	-	306610	316315-5	20
7535-4	55	1 pt/ 6 strokes	5-1/2	326750-E1	-	-	306610	336899	20
8570-5	16	1QT/ 9 strokes	5-1/2	-	328245-4	3631	306610	316315-5	35
ATF									
8571-5	16	1QT/ 9 strokes	317809-5F	-	328245-4	3630	321203 317860-1 B326302	316315-5	38

Bold print indicates included with pump.

Maintenance, Repair & Operations

Alemite™

FITTINGS

1/4" - 28 Taper Thread Hydraulic Fittings

Used on most cars and trucks and on many industrial machines. Features dirt excluding ball check. Maximum pressure: 10,000 psi.

Fitting	Type	Overall Length (in)	Shank Length (in)	Hex Size (in)
1641-B	Str.	35/64	3/16	5/16
1652-B	Str.	11/16	23/64	5/16
1680-B	Str.	31/32	5/8	5/16
1698-B	Str.	1-1/8	25/32	5/16
3014-B	Str.	1-5/8	1	5/16
1637-B1	45°	13/16	13/64	3/8
3010-B1	65°	25/32	19/64	3/8
1911-B1	90°	3/4	13/64	3/8

SAE-LT - conforms to Society of Automotive Engineers lubrication thread specification.

1641-B (MS-15001-1) ▶
(9411027) GM/CH
(271287) GM
(87907-S8) Ford



1/4"-28 TAPER THD. (SAE-LT)

1652-B (9411028) GM/CH
(273326) GM

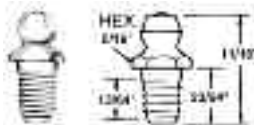

1/4"-28 TAPER THD. (SAE-LT)

1680-B (MS-15001-2) ▶
(271288) GM
(9411029) GM/CH

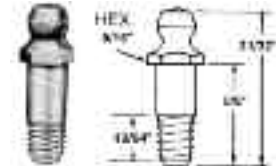

1/4" - 28 TAPER THD. (SAE-LT)

1698-B (128274) GM

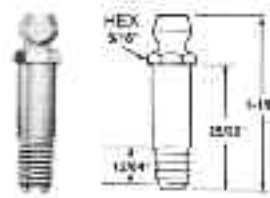

1/4" - 28 TAPER THD. (SAE-LT)

3014-B

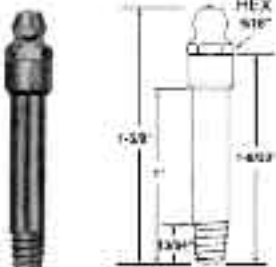

1/4"-28 TAPER THD. (SAE-LT)

1637-B1 (MS-15001-3) ▶
(9411030) GM/CH
(274508) GM

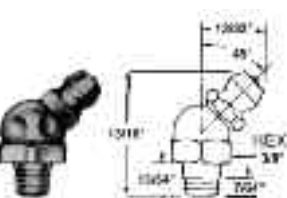

1/4"-28 TAPER THD. (SAE-LT)

3010-B1

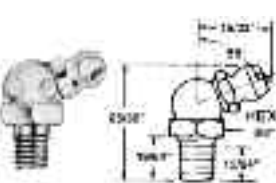

1/4"-28 TAPER THD. (SAE-LT)

1911-B1 (MS-15001-4) ▶
(9411032) GM/CH
(274510) GM

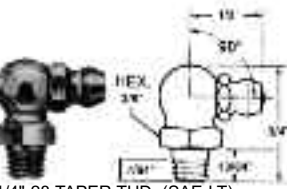

1/4"-28 TAPER THD. (SAE-LT)

It is recommended that SAE-LT taper threads be assembled into 1/4" - 28 UNF, Class 3B, straight threaded holes having a modified maximum minor diameter of 0.2151 in. to insure 75% minimum thread height.

1/4" - 28 Straight Thread

Fitting	Type	Overall Length (in)	Shank Length (in)	Hex Size (in)
1792-B	Str.	33/64	5/32	9/32
1770-B1	45°	39/64	1/8	3/8

1792-B (MS-15002-1) ▶
(9411244) GM
(271291) GM



1/4" - 28 UNF-2A

1770-B1 (MS-15002-3) ▶

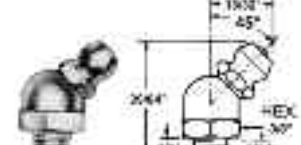

1/4" - 28 UNF-2A

1/8" PTF Hydraulic Fitting

Used on many industrial machines and heavy equipment. Features dirt excluding ball check. Maximum pressure: 10,000 psi.

Fitting	Type	Overall Length (in)	Shank Length (in)	Hex Size (in)
1644-B	Str.	9/16	15/64	7/16
1610-BL	Str.	11/16	19/64	7/16
1607-B	Str.	1-1/4	25/32	7/16
1669-B	Str.	1-3/4	1-17/64	7/16
1684-B	Str.	2-5/8	2-3/16	3/8
1618-B*	Str.	1	9/32	1/2
1958**	Str.	31/32	1/4	7/16
1611-B	30°	29/32	19/64	7/16
1638-B	30°	2-3/32	3/16	7/16
1688-B	45°	57/64	19/64	7/16
1620-B*	45°	1-1/8	13/32	7/16 SQ.
1612-B	65°	27/32	19/64	7/16
1623-B	65°	1-7/32	9/16	7/16
1649-B	65°	2-3/4	2-1/4	3/8
1613-B	90°	27/32	19/64	7/16
1606-B	90°	1-13/16	1-1/4	7/16

Note: * NPTF Female, ** Features dirt excluding ball check

1644-B



SAE Spec. Extra Short

1610-BL (MS-15003-1) ▶
(9411010) GM/CH



(191758) GM SAE Spec. Extra Short
(138332-H) IH

1607-B (MS-15003-2) ▶
(9411011) GM/CH
(271281) GM

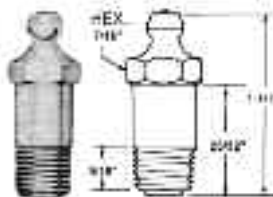

1669-B (273347) GM
(9411012) GM



1684-B (273348) GM
(9411013) GM



1618-B (273350) GM
(9411026) GM

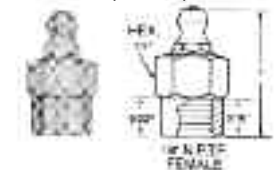

- continues -

24
Maintenance
Repair
Operations

Alemite™

1/8" PTF Hydraulic Fittings (continued)

1611-B (MS-15003-3) ▶
 (9411014) GM/CH
 (271282) GM

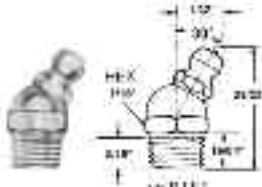

1958** (190811) GM

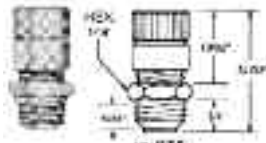

SAE Spec. Extra Short

**Designed for DUSTPROOF apps.
 Cap provides a second seal.

1688-B (MS-15003-4) ▶
 (271283) GM/IH
 (9411016) GM

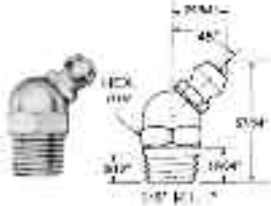

1638-B (9411015) GM/CH
 (273327) GM

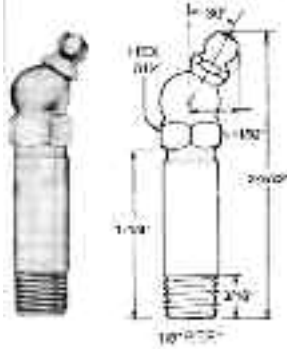

1612-B (MS-15003-5) ▶
 (9411017) GM/CH
 (271284) GM

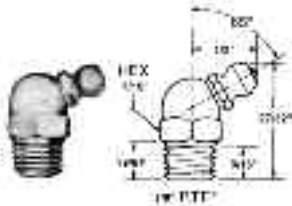

1620-B

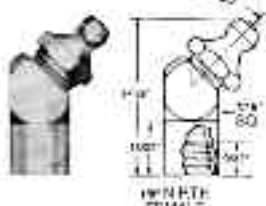

1649-B (273348) GM
 (9411013) GM

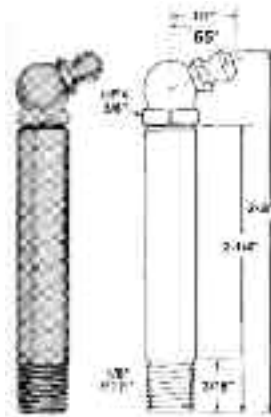

1623-B (273351) GM
 (9411018) GM

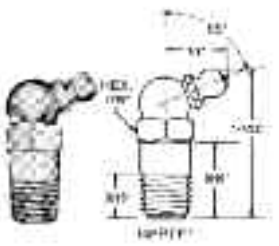

1613-B (MS-15003-6) ▶
 (9411019) GM/CH
 (271285) GM/IH

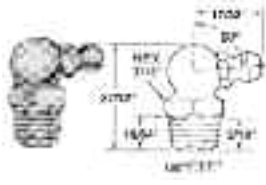

1606-B (9411020) GM/CH
 (273352) GM

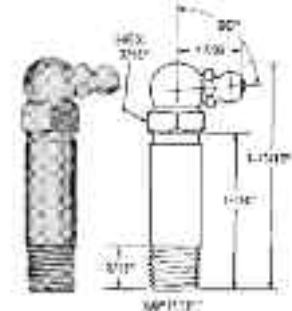

1/4" PTF Hydraulic Fittings

Widely used for larger bearings on farm machinery and heavy industrial equipment. Recommended for heavy lubricants in cold weather. Features dirt excluding ball check. Maximum pressure: 10,000 PSI.

Fitting	Type	Overall Length (in)	Shank Length (in)	Hex Size (in)
1627-B	Str.	7/8	27/64	9/16
1629-B	67-1/2°	31/32	11/32	9/16

1627-B (273349) GM

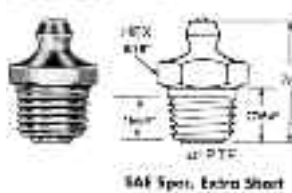

SAE Spec. Extra Short

1629-B

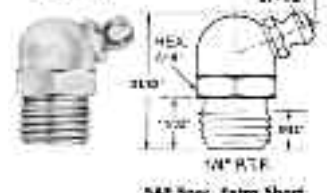

SAE Spec. Extra Short

Thread Forming Fittings

Thread forming fittings have special tapered drive threads to reshape the material in an untapped hole to provide a leak-proof seal. They are most effectively installed by spinning into the untapped hole, but they also may be driven straight into the untapped hole. Thread forming fittings may be replaced by any standard threaded fitting, or by another thread forming fitting that is spun. All Alemite thread forming fittings are dyed yellow for identification purposes. Maximum pressure: 10,000 psi.

Fitting	Thread (in)	Type	Hex Size (in)	Recommended Hole Size
3038-B	1/4"-28 Spl. Taper	Str.	5/16	.230 - .235
3053-B	1/4"-28 Spl. Taper	45°	3/8	.230 - .235
3054-B	1/4"-28 Spl. Taper	90°	3/8	.230 - .235
1720-B	1/8" Spl. Taper	Str.	7/16	.373 - .380
1724-B	1/8" Spl. Taper	45°	7/16	.373 - .380
1722-B	1/8" Spl. Taper	65°	7/16	.373 - .380
1723-B	1/8" Spl. Taper	90°	7/16	.373 - .380

3038-B



1/4"-28 SPECIAL TAPER THD.
 (Recommended hole size - .230 to .235)

3053-B

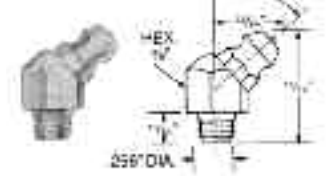

1/4"-28 SPECIAL TAPER THD.
 (Recommended hole size - .230 to .235)

3054-B



1/4"-28 SPECIAL TAPER THD.
 (Recommended hole size - .230 to .235)

1720-B (9411022) GM/CH
 (273321) GM

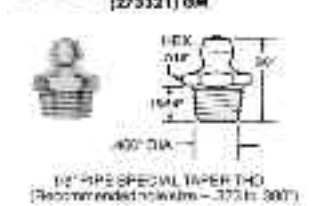

1/2" PIPE SPECIAL TAPER THD.
 (Recommended hole size - .373 to .380)

1724-B



1/2" PIPE SPECIAL TAPER THD.
 (Recommended hole size - .373 to .380)

1722-B (9411024) GM/CH
 (273323) GM

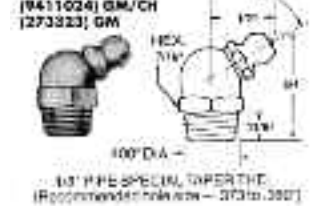

1/2" PIPE SPECIAL TAPER THD.
 (Recommended hole size - .373 to .380)

1723-B (9411025) GM/CH
 (273324) GM

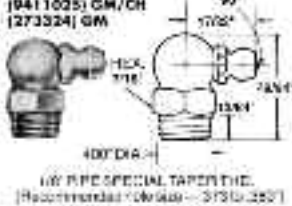

1/2" PIPE SPECIAL TAPER THD.
 (Recommended hole size - .373 to .380)

24 Maintenance Repair Operations

Maintenance, Repair & Operations

Alemite™

Drive Fittings

Used extensively to avoid tapping costs in a wide variety of applications. Alemite serrated shank grips securely and simplifies the replacement of damaged fittings in old or oversized holes. Recommended only for low and medium pressures.

Fitting	Type	Overall Length (in)	Shank Length (in)	Drill Dia. (in)
1736*	Str.	9/16	1/4	1/8
3019*	Str.	15/32	5/32	1/8
3009*	Str.	25/64	3/32	3/16
3005*	Str.	15/32	11/64	3/16
3006*	Str.	31/64	7/32	3/16
1728-B	Str.	33/64	1/4	3/16
1633*	Str.	5/8	1/4	3/16
1743-B	Str.	35/64	1/4	1/4
321381*	Str.	9/16	17/64	1/4
1952*	Str.	15/32	1/8	1/4
1608-B	Str.	35/64	1/4	5/16
1699*	Str.	5/8	7/32	5/16
1666*	Str.	37/64	7/32	3/8
1992-B1	45°	53/64	7/32	3/16
1646-B1	65°	45/64	7/32	3/16
1744-B1	65°	49/64	9/32	1/4
1630-B1	65°	45/64	7/32	5/16

NOTE: *No ball check
IMPORTANT: Actual drill sizes cannot be shown because drilling varies with hardness of metal. Drill sizes indicated on drawings are merely a guide. Exact drill size can only be determined by sample drilling of the actual metal. When drilled to proper tolerance, the serrated edge of the fitting will provide a secure, lasting grip.

Drive Fittings (continued)

1646-B1

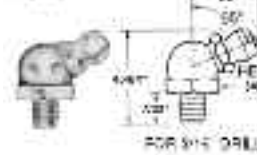

1744-B1

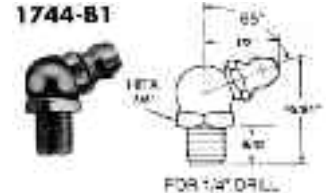

1630-B1

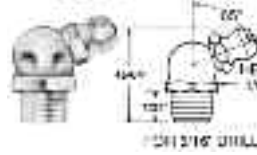

For Straight-Type Drive Fittings

Tool	For Drive Fitting
5253	1633, 1666, 1699, 1720-B, 1736, 1952, 3005, 3009, 3019
5253-1	1608-B, 1743-B, 3038-B, 321381
5253-2	3006
5253-3	1728-B

For Angle-Type Drive Fittings

Tool	For Drive Fitting
5254-1	1630-B1, 1646-B1, 1744-B1, 1992-B1, 1722-B, 1723-B, 1724-B

Metric Fittings

Taper metric thread conforms to German Standard DIN 71412. Maximum pressure 10,000 psi.

Fitting	Type	Thread (m)	Overall Length (in)	Shank Length (in)	Hex Size
2106	Str.	6mm x 1mm	19/32	1/4	7 mm
2107	45°	6mm x 1mm	13/16	7/32	10 mm
2108	90°	6mm x 1mm	3/4	7/32	10 mm
2103	Str.	8mm x 1mm	5/8	1/4	9 mm
2105	90°	8mm x 1mm	3/4	7/32	10 mm
2109	Str.	10mm x 1mm	5/8	1/4	11 mm

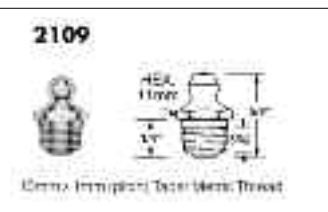
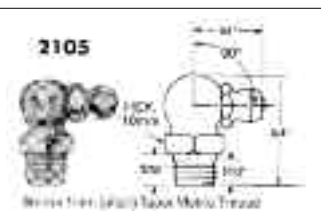
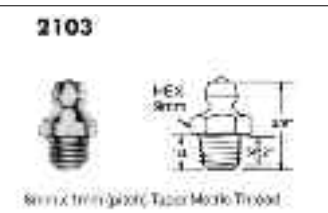
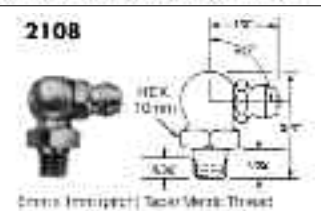
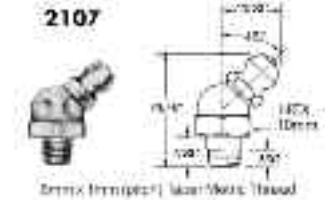
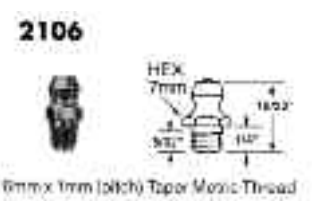
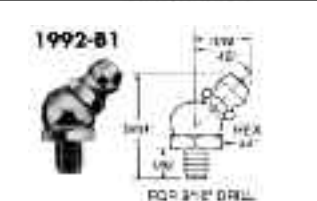
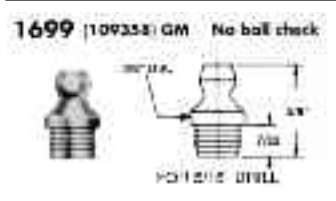
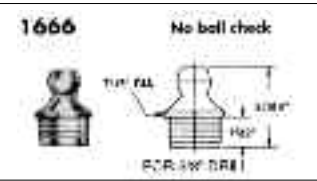
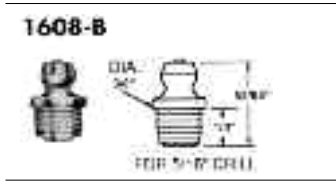
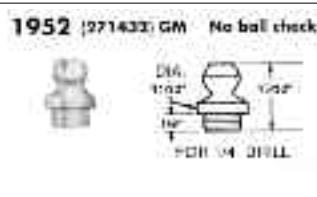
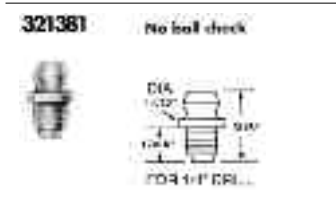
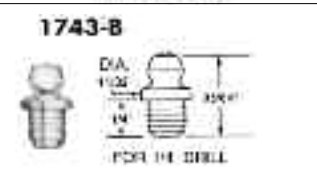
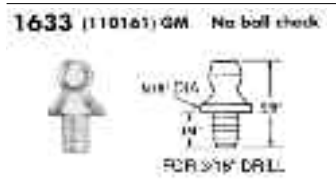
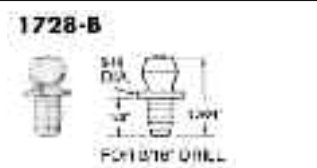
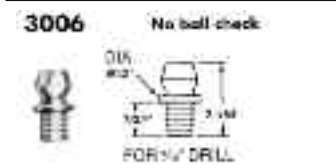
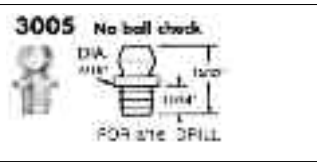
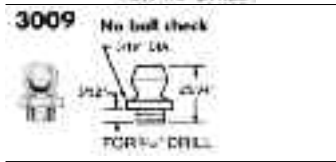
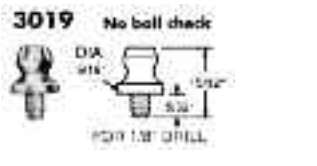

Alemite™

Non-Corrosive Fittings

Alemite non-corrosive fittings withstand the most severe corrosive conditions under which metal equipment can be used - in both marine and industrial applications. All Monel fittings have a single notch on the hex and all stainless steel fittings have two notches on the hex for easy identification.

Monel

Fitting	Type	Thread	Overall Length (in)	Shank Length (in)	Hex Size (in)
1966-B	Str.	1/4"-28 Taper	17/32	3/16	5/16
1968-B	45°	1/4"-28 Taper	13/16	13/64	3/8
1969-B	90°	1/4"-28 Taper	3/4	13/64	3/8
1962-B	Str.	1/8" P.T.F.	5/8	9/32	7/16
1961-B	Str.	1/8" P.T.F.	3/4	5/16	7/16
1921-B	30°	1/8" P.T.F.	1-1/4	11/32	7/16
1922-B	67-1/2°	1/8" P.T.F.	61/64	11/32	7/16
1923-B	90°	1/8" P.T.F.	7/8	11/32	7/16

Stainless Steel

Fitting	Type	Thread	Overall Length (in)	Shank Length (in)	Hex Size (in)
1966-S	Str.	1/4"-28 Taper	17/32	3/16	5/16
1968-S	45°	1/4"-28 Taper	13/16	13/64	3/8
1969-S	90°	1/4"-28 Taper	3/4	13/64	3/8
1961-S	Str.	1/8" P.T.F.	3/4	5/16	7/16
1921-S	30°	1/8" P.T.F.	1-1/4	11/32	7/16
1922-S	67-1/2°	1/8" P.T.F.	61/64	11/32	7/16
1923-S	90°	1/8" P.T.F.	7/8	11/32	7/16

Note: Bodies are made of Type 303 stainless steel - balls are of Type 440 stainless steel and tempered springs are of Type 302 stainless steel. To order, add suffix "S" to part number, i.e. 1921-S, 1922-S, etc.

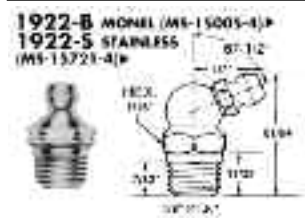
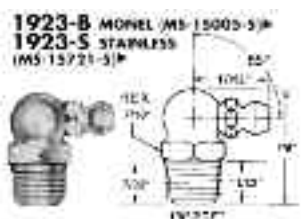
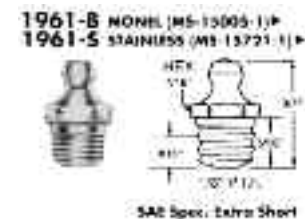
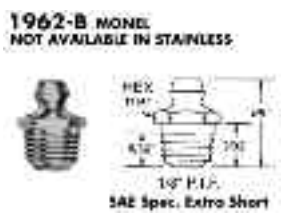
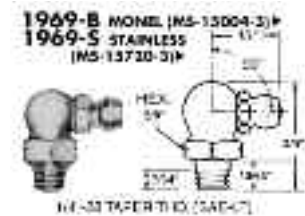
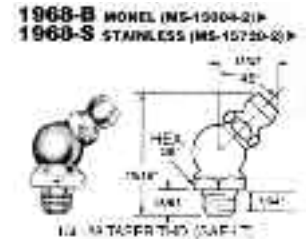
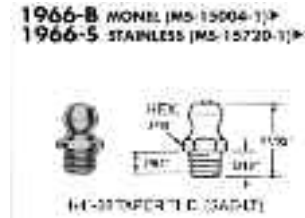

Standard Button Head Fittings

For rugged applications such as heavy machinery or contractor's equipment. All are straight fittings. Button head is 5/8" diameter. Maximum pressure: 6,000 psi.

Fittings	Thread (in)	Overall Length (in)	Shank Length (in)	Hex Size (in)
A1184	1/8" PTF	3/4	11/32	5/8
A1186	1/4" NPTF	53/64	27/64	5/8
1401	1/4" NPTF	7/8	15/32	5/8
A1188	3/8" NPTF	61/64	31/64	3/4
A1190	1/2" NPTF	1-1/16	35/64	7/8
C-69	1/8" NPTF(f)	31/32	13/32	5/8
M1184*	1/8" PTF	3/4	11/32	5/8

NOTE: *Non-corrosive Monel

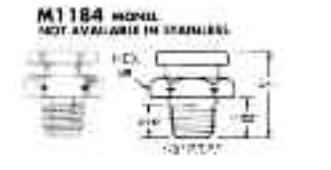
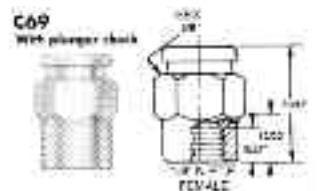
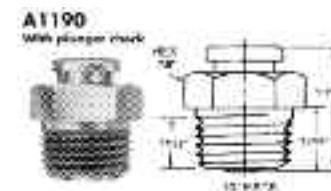
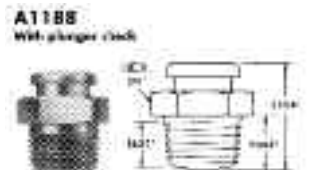
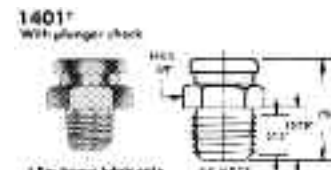
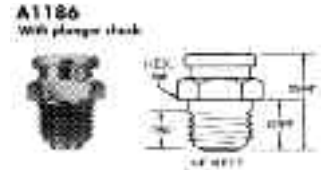
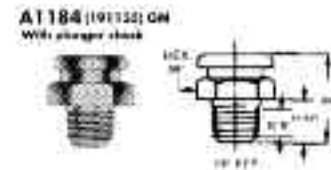

NOTE: *Non-corrosive Monel

Button Head Couplers

For use with standard or giant button head fittings.

Type	7/16"-27 NS-2(f) Thd.	1/8" NPTF (f) Thd.	1/4" PTF SAE Short (f) Thd.
Std. Pull-On	42030	42030-A	-
Std. Push-On	-	42031-A	-
Giant Pull-On	304300	304300-A	319702
Giant Hook-On	304301	-	-

Giant Button Head Fittings

Similar to standard button head fittings except larger (7/8" diameter) to withstand the roughest usage. All are straight fittings. Maximum pressure: 15,000 psi.

Fittings	Thread (in)	Overall Length (in)	Shank Length (in)	Hex Size (in)
1823-1	1/4" NPTF	1-1/4	1/2	7/8
1822-A1	3/8" NPTF	1-5/16	9/16	7/8
1820-1	1/2" NPTF	1-1/16	1/2	7/8

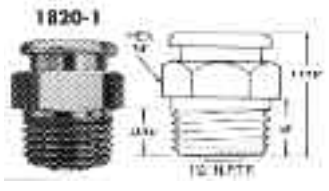
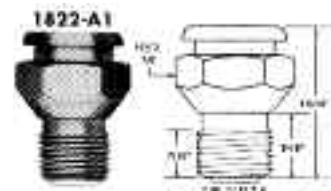
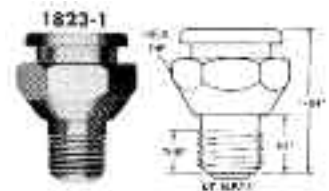

24
 Maintenance
 Repair
 Operations

Maintenance, Repair & Operations

Alemite™

Giant Button Head Couplers

Type	7/16"-27 NS-2(f) Thd.	1/8" NPTF (f) Thd.	1/4" PTF SAE Short (f) Thd.
Giant Pull-On	304300	304300-A	319702
Giant Hook-On	304301	-	-

Relief Fittings

For use on gear box housings and bearings, (such as king pins, universal joints, etc.), where excessive lubricant pressures are not desirable. These safety valves open at the pre-determined pressures shown in table. All relief fittings are 1/8" PTF SAE special short threads.

Relief Fitting	Pressure (psi)		Overall Length (in)	Shank Length (in)	Hex Size (in)
	Min.	Max.			
317400	1/4	1	1/2	19/64	7/16
47200	1	5	1/2	19/64	7/16
47640	7-1/2	15	1/2	19/64	7/16
323060	15	25	1/2	19/64	7/16
47100	45	80	1/2	19/64	7/16
50500	400	650	1/2	19/64	7/16
321839	1	5	1/2	-	-
338382	80	140	9/16	11/32	7/16



1/8" PTF
*SAE Special Short
Drive Fitting (3/8" Drill)
Leakproof (1/8" PTF)

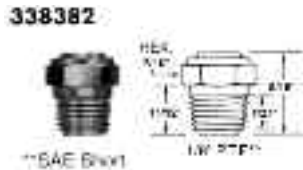
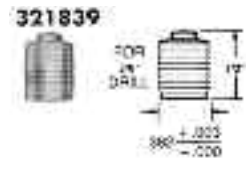

Flush Type Couplers

Used with rigid extension for flush type fittings.

Nozzle	Type	Thread NPTF
314150*	Midget	1/8" (f)
Z737	Standard	1/8" (f)

Rivet Fitting

Recommended for special applications where threaded or drive fittings cannot be used. Commonly used for king pin applications.

Fitting	Type	Overall Length (in)	Fitting Dia. (in)	Rivet Dia. (in)
1675-B	Str.	1/2	3/8	5/16



Pin Type Fittings

Positive locking action of coupler and cross pins assures leakproof connection.

Fitting	Type	Thread (in)	Overall Length (in)	Shank Length (in)	Drill Dia. (in)
A336	Str.	1/8" PTF	31/32	17/64	7/16
A359	Str.	1/4" NPTF	1-3/32	5/16	17/32
M336**	Str.	1/8" PTF	31/32	17/64	7/16

NOTE: **Brass

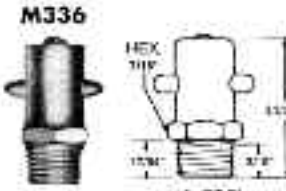
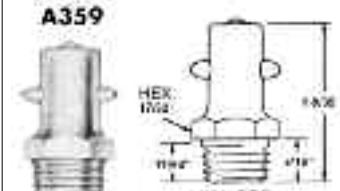
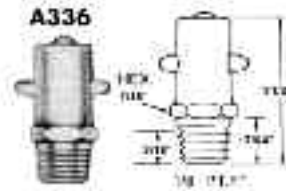

*SAE Special Short

Flush Type Fittings

For installations where protruding fittings cannot be used. Fittings sit flush, and are not easily damaged. For use on line shafting pulleys or revolving bearings. Fitting 1814 is a drive type oiler for lubrication with an ordinary oil can.

Fitting	Type	Thread	Overall Length (in)	Shank Length (in)	Drill Dia. (in)
1815	Slotted	1/8" NPTF	23/64	19/64	-
1452	Slotted	1/8" NPTF	17/32	-	-
Z741-A	Slotted	1/4" NPTF	9/16	-	-
1851	Hex	1/4-28" NF	13/32	19/64	-
3036	Str.	Drive	3/8	5/16	3/16
1877	Str.	Drive	11/64	1/8	.123 - .125
1885	Str.	Drive	9/32	15/64	1/4
1814	Str.	Drive	21/64	9/32	5/16

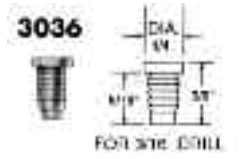
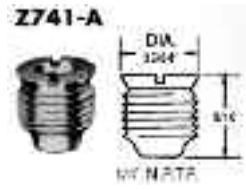
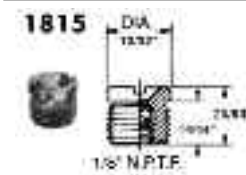

Pin Type Couplers

Provides quick, positive, and leakproof connection with pin type fittings.

Part No.	Thread
VB-942	1/8" NPT (f) without wing
50491	1/8" NPT (f) with wing
5118	1/8" NPTF (f) with wing

Hydraulic Shut-Off Fittings

Fittings positively shut-off at pressures specified, preventing over-lubrication and blowing out of bearing seals. 1/8" PTF thread.

Fitting	Type	Overall Length (in)	Shank Length (in)	Hex Size (in)	Shut-Off Pressure
1940-B	60°	1	17/64	5/8	5-20 lbs.
1795-B	60°	1	17/64	5/8	60-110 lbs.

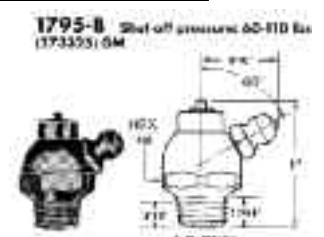
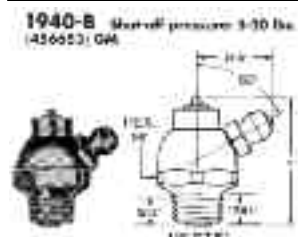

*SAE Special Short Threads

24
Maintenance
Repair
Operations

Alemite™

Leakproof Fittings

Leakproof fittings have a Buna-N seal instead of a ball check - for light oils and other fluids up to 5,000 lbs. applied pressure.

Fitting	Type	Thread (in)	Overall Length (in)	Shank Length (in)	Hex Size (in)
1650	Str.	1/8 NPT	29/32	25/64	7/16
1692	30°	1/8 NPT	1-7/32	25/64	7/16
1693	90°	1/8 NPT	31/32	25/64	7/16
1634	Str.	1/8 PTF	27/32	23/64	7/16
1634-B †	Str.	1/8 PTF	1	33/64	7/16

NOTE: † Has double ball check and brass insert seat for grease, heavy and medium oils. Up to 10,000 lbs. applied pressure.

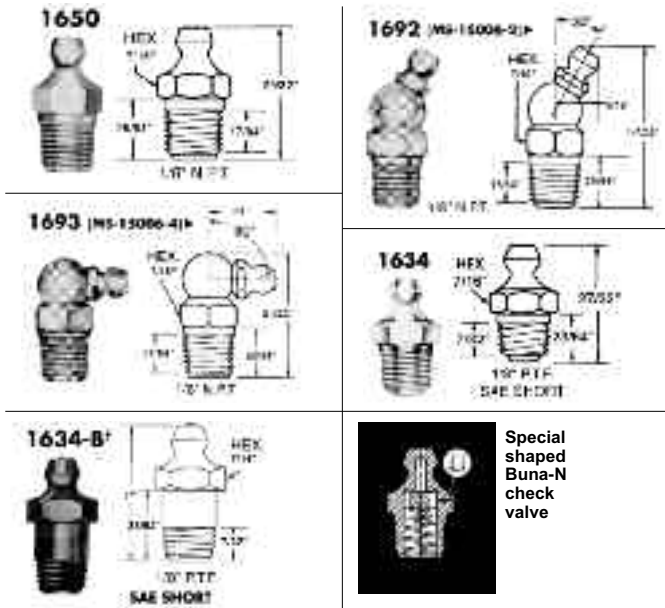

Air Vents

For use on transmissions, differentials, speed reducers, gear housings, etc., (above normal level of lubricant) - allows air to escape when internal pressures are built up. Special cap prevents water or dirt from entering.

Vent	Overall Type	Shank Length (in)	Opening Length (in)	Hex Pressure	Size (in)
300805	Breather	1	17/64	-	7/16
304810	Valve	1	17/64	1-3" water	7/16
131000	Valve	1	17/64	12" water max	7/16
327240	Valve	1	17/64	1 to 1-1/2 psi	7/16
330766	Valve	1	17/64	3-1/2 to 4 psi	7/16
301370	Breather	25/32	17/64	-	7/16
321620+	Breather	25/32	17/64	-	7/16
326315**	Breather	1-11/32	21/64	-	11/16
313650**	Breather	1-1/2	33/64	-	3/4

NOTE: + Zinc Dichromate Plating *SAE Special Short
 **Two Baffles 1" water = .03613 psi

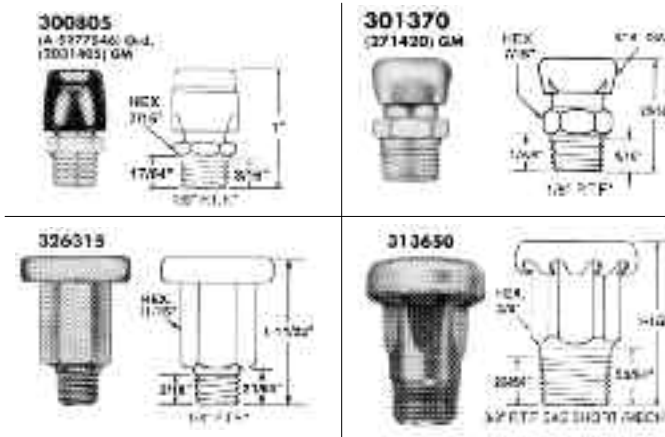

Special Thread

Special threads and sizes for special lubrication purposes. All have high pressure ball check unless otherwise specified.

Fitting	Thread Type	Overall (in)	Shank Length (in)	Hex Length (in)	Size (in)
3016*	Str.	10-32 UNF-2A	1/2	1/8	1/4
3018	Str.	6-40 UNF-2A	1/2	7/64	1/4
1711-B	Str.	5/16"-24 UNF-2A	21/32	5/32	3/8
1631-B	Str.	5/16"-32 UNEF-2A	21/32	15/64	3/8
1648-B1	65°	5/16"-32 UNEF-2A	51/64	7/32	3/8

*No ball check

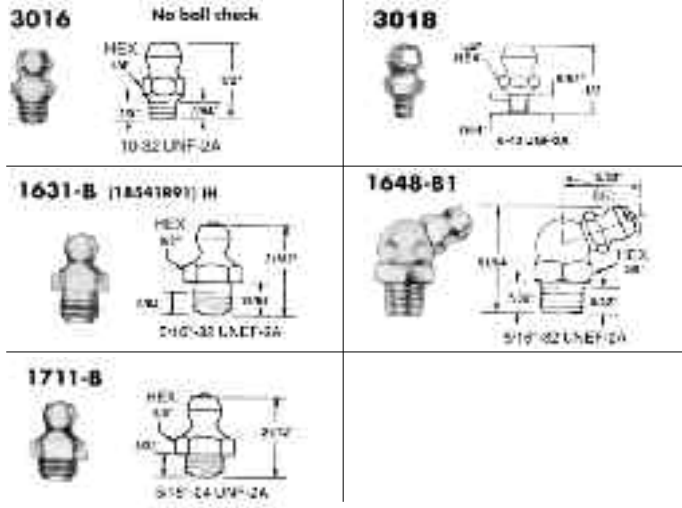

Plugs

Fitting	Description
1480	1/8" N.P.T.F. Square Head
17831	1/8" N.P.T.F. Hex Socket
170008	1/4" N.P.T.F. Hex Socket
69795	1/8" N.P.T.F. Slotted
328224	1/4"-28 Taper Thd. (SAE-LT) Hex Head
328435	1/4"-28 Taper Thd. (SAE-LT) Thread Forming Hex Head

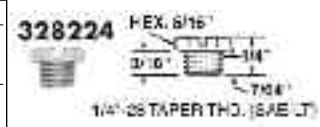

Assortments

Vehicle Fitting Assortment Assortment 2398-1

Box contains six types of popular fittings. An identifying chart is included in the cover. Assortment includes:

Fitting	Type	Thread (in)	Quantity
1610-BL	Str.	1/8" P.T.F.	24
1688-B	45°	1/8" P.T.F.	12
1613-B	90°	1/8" P.T.F.	12
1641-B	Str.	1/4"-28 Taper	24
1637-B1	45°	1/4"-28 Taper	12
1911-B1	90°	1/4"-28 Taper	12



All Purpose Fitting Assortment Assortment 2364-1

Metal box contains eight types of popular fittings. Also includes two tools for extracting fittings and rethreading holes. An identifying chart is included in the cover. Assortment includes:

Fitting	Type	Thread (in)	Quantity
1610-BL	Str.	1/8" P.T.F.	36
1611-B	30°	1/8" P.T.F.	12
1688-B	45°	1/8" P.T.F.	12
1612-B	65°	1/8" P.T.F.	12
1613-B	90°	1/8" P.T.F.	12
1641-B	Str.	1/4"-28 Taper	24
1637-B1	45°	1/4"-28 Taper	12
1911-B1	90°	1/4"-28 Taper	12
315790	Fitting Tool	for 1/4"-28 thread fitting	(1)
317591	Fitting Tool	for 1/8" PT fitting	(1)



Maintenance, Repair & Operations

Alemite™

Metric Fitting Assortment

Assortment 2371

Box contains six types of popular metric fittings. An identifying chart is included in the cover. Thread conforms to German Standard DIN 71412. Assortment includes:

Fitting	Type	Thread (m)	Quantity
2106	Str.	6mm	10
2107	45°	6mm	6
2108	90°	6mm	6
2103	Str.	8mm	6
2105	90°	8mm	6
2109	Str.	10mm	10

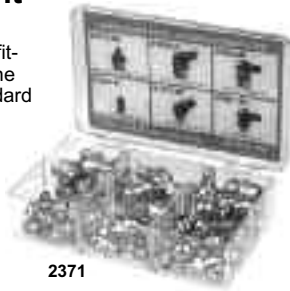

2371

Pocket Pack Fitting Assortment

Assortment 2365-1

Box contains six types of popular fittings. An identifying chart is included in the cover. Assortment includes:

Fitting	Type	Thread (m)	Quantity
1610-BL	Str.	1/8" PTF	12
1688-B	45°	1/8" PTF	6
1613-B	90°	1/8" PTF	6
1641-B	Str.	1/4"-28 Taper	12
1637-B1	45°	1/4"-28 Taper	6
1911-B1	90°	1/4"-28 Taper	6



2365-1

Couplers:

Button Head Couplers

For use with standard or giant button head fittings.

Type	7/16"-27 NS-2 (I) Thd.	1/8" NPTF 1/4" (I) Thread	PTF SAE Short (I) Thd.
Std. Pull-On	42030	42030-A	-
Std. Push-On	-	42031-A	-
Giant Pull-On	304300	304300-A	319702
Giant Hook-On	304301	-	-



Flush Type Couplers

Used with rigid extension for flush type fittings.

Nozzle	Type	Thread NPTF
314150*	Midget	1/8" (f)
2737	Standard	1/8" (f)

*314150 is used on 1877 flush-type fitting



Hydraulic Couplers

Provides quick, positive and leakproof connection with hydraulic fittings.

Part No.	Type	Thread
6304-B	Standard	1/8" NPTF (f)
6304-C*	Standard	1/8" NPTF (f)
308730	Narrow	1/8" NPTF (f)
308730-A*	Narrow	1/8" NPTF (f)
330070**	Narrow	1/8" NPTF (f)

*Equipped with built-in check valve
**High pressure, metal seal



308730-A

Pin Type Couplers

Provides quick, positive, and leakproof connection with pin type fittings.

Part No.	Thread
VB-942	1/8" NPTF (f) without wing
50491	1/8" NPTF (f) with wing
5118	1/8" NPTF (f) with wing



50491

Swivel Hydraulic Couplers

Couplers swivel full 360 degrees, lock in any of eight positions. Use 1/8" NPTF pipe extension to connect coupler to gun outlet.

Part No. 6509-D Standard swivel coupler. Metal seal, length: 3-1/2".

Part No. 6509-E Narrow diameter swivel coupler. Rubber seal, length: 4".



6509-D

Fitting Extensions

1/8" NPTF (f) x 1/8" P.T.F. SAE Special Short (m)

Fitting	A Angle (in)	B Overall Length (in)	C Thread Length (in)	D Shank Length (in)
43761	3/4	3/16 *	9/32	1/2
43762	1-1/4	17/64	11/16	1/2

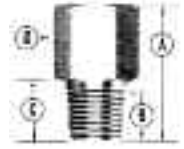

Adapters

Fitting	Type	Thread
51942	Str.	1/4"-28 Taper Thread (SAE-LT) (m) x 1/8" NPTF (f)
51943	90°	1/4"-28 Taper Thread (SAE-LT) (m) x 1/8" NPTF (f)
310912	45°	1/4"-28 Taper Thread (SAE-LT) (m) x 1/8" NPTF (f)

Bushings

Fitting	A Female NPTF (in)	B Male NPTF (in)	C Hex Size (in)	D Overall Length (in)	E (&) Thread Length (in)	F Shank Length (in)
A112	1/8 *	3/8	11/16	17/32	13/32	3/8
A113	1/8 *	1/2	5/8 (Sq.)	21/32	1/2	5/8 (Sq.)
40996	1/4	3/8	3/4	23/32	13/32	37/64
45120	1/8	1/4	9/16	3/4	13/32	1/2
131586	3/8	1/2	7/8	25/32	17/32	9/16

*N.P.S.I. Pipe Thread

Elbow Bodies

Fitting	A Angle°	B Overall Length (in)	C Thread Length (in)	D Shank Length (in)
1/8" NPTF (f) x 1/8" PTF SAE Short (m)				
43706	90°	1-1/8	17/64	17/32
43716	45°	1	7/32	7/16
44701	90°	1	7/32	7/16
1/8" NPTF (f) x 1/4" PTF SAE Short (m)				
43718	90°	1-3/16	13/32	5/8
1/4" NPTF (f) x 1/4" PTF (m)				
43748	90°	1-11/32	13/32	19/32

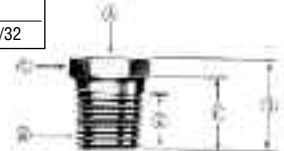
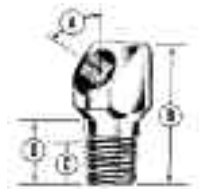

Drive Tools for Straight and Angle-Type Drive Fittings

These special tools simplify the original installation of Drive and Thread Forming fitting in untapped holes.

For Straight-Type Drive Fittings

Tool	For Drive Fitting
5253	1633, 1666, 1699, 1720-B, 1736, 1952, 3005, 3009, 3019
5253-1	1608-B, 1743-B, 3038-B, 321381
5253-2	3006
5253-3	1728-B



For Angle-Type Drive Fittings

Tool	For Drive Fitting
5254-1	1630-B1, 1646-B1, 1744-B1, 1992-B1, 1722-B, 1723-B, 1724-B

Easy-Out Fitting Tools

All-in-one tool to extract broken fittings, rethread holes and install new straight and angle-type fittings.

Tool	For Fittings With Thread
B315790	1/4"-28 Taper Thread
B315791	1/8" NPTF



B315790

Alemite™/CH Hanson Co.

Header Blocks

Hard-to-reach machine bearings requiring lubrication can be connected to central points by tubing or whip hose leading from the bearings to header blocks. Blocks equipped with hydraulic fittings are available for three or six bearings. With compression fitting connections for 1/4" tubing. Inlet/outlet threads are 1/8" NPTF (f).

Part No.	Size	Length (in)	Block Only
6135	3-point	2-3/4	42702
6136	6-point	5-3/4	42703



How to Determine Pipe Thread Sizes:

Male Threads - Measure outside diameter or large portion of thread at "A"; find figure nearest this dimension in column I of chart; and directly opposite in column II is the nominal pipe (or Pipe Thread) size.

Female Threads - Measure outside diameter of thread at "B"; find figure nearest this dimension in column I of chart; and directly opposite in column II is the nominal pipe (or Pipe Thread) size.

Outside Approx. (Fraction) inch	I Actual (Decimal) inch	II Nominal (P.T.) inch	Nominal Engagement for Tight Joint (Dim. "C") inch	No. of Threads per inch
13/32	.405	1/8	1/4	27
35/64	.540	1/4	3/8	18
43/64	.675	3/8	3/8	18
27/32	.840	1/2	1/2	14
1-3/64	1.050	3/4	9/16	14
1-5/16	1.315	1	11/16	11-1/2
1-21/32	1.660	1-1/4	11/16	11-1/2
1-29/32	1.900	1-1/2	11/16	11-1/2
2-3/8	2.375	2	3/4	11-1/2

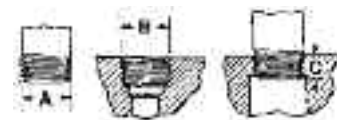

Seal can be maintained up to 20° total angularity range.

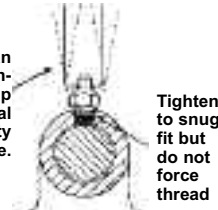

Tighten to snug fit but do not force thread

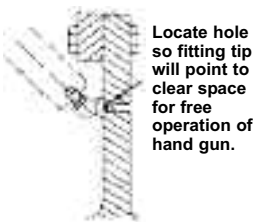

Locate hole so fitting tip will point to clear space for free operation of hand gun.

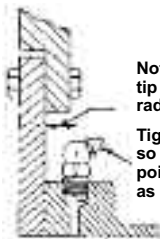

Note required tip turning radius.
Tighten fitting so that tip will point outwards as shown.

American National Pipe Thread Code

P.T.F. – SAE short taper pipe thread

N.P.T.F. – American National taper pipe thread for Dryseal pressure-tight joints

N.P.S.M. – American National straight pipe thread for mechanical joints

N.P.S.I. – American National straight intermediate pipe thread

CH Hanson Co.

REESE'S BRASS ADJUSTABLE STENCILS

- Durable brass stencils slide together and come apart easily.
- Use brush or spray ink, paint or markers.
- Quick, legible signs on all surfaces.

Sets contain the following:

- NUMBERS ONLY, SINGLE SETS

(15 pieces): 1-9, 0, 0, Beginner, Plain Ender, Period, Dash



- LETTERS ONLY, SINGLE SETS (33 pieces): A-Z, &, Beginner, Period Ender, Spacer, Comma, Dash, Period.

- LETTERS & NUMBERS (92 PIECES): AAA, BB, CC, DD, EEEE, FF, GG, HH, III, JJ, KK, LL, MM, NNN, OOO, PP, Q, RR, SSS, TT, UU, VV, WW, XX, ZZ, &&, 111, 22, 33, 44, 55, 66, 77, 88, 99, 000, Beginner, Plain Ender, 3 Spacers, Comma, Dash, 2 Periods.

ITEM CODE NUMBERS - GOTHIC STYLE CHARACTERS

Size (in)	Numbers 15 pcs.	Letters 33 pcs.	Letters & No's 92 pcs.
1/2	10006	10026	10146
3/4	10007	10027	10147
1	10008	10028	10148
1-1/2	10009	10029	10149
2	10011	10031	10151
2-1/2	10012	10032	10152
3	10013	10033	10153
4	10014	10034	10154
5	10015	10035	10155
6	10016	10036	10156
Note: Following larger size number sets have only 13 pieces: 0-9, Beginner, Plain Ender, Period, Letter sets are same assortment as smaller sizes. Combination sets not available in larger sizes.			
8	10160	10165	-
10	10161	10166	-
12	10162	10167	-

Lead Sealing Press (27905)

- Strong, small press (2-1/2" x 5" closed).
- Copy of up to 4 characters is available to mark lead seals.



Maintenance, Repair & Operations

Crown
Crown

LUBRICANTS

Cutting Oil

All Purpose Lubricant and Coolant

Handles Extreme Temperature and Pressure Requirements.

This cutting oil is designed for applications requiring cooling and lubricating at the point of work. Excellent for difficult operations (grinding, deep drawing and forming). Safe for hard and soft metals. Transparent on the surface; easy removal with commercial cleaners.

- Provides maximum lubricity for ferrous and non-ferrous machining. Reduces down-time and sharpening needs; extends tool life.
- Clings at any angle!
- Easy to spray hard-to-reach areas for more complete coverage. Fine adhesion means less waste.

Applications: Turret lathes, gear cutter, grinders, automatic screw machines and pipe threaders.



Size	Part No.
12 AV OZ. aerosol	7020
1 gallon	7021
5 gallon	7022

Tap Tool

Produces Cleaner Threads

Reduces friction on the surface, acts as an anti-weld on the bottom. Carries heat away from the tool and cutting edge. Reduces tap breakage. Increase tool life by as much as 200%. Contains no sulfur and is not petroleum based. Excellent for all metals, including aluminum, stainless steel and titanium.

Applications: Drilling, tapping, milling, threading, boring, broaching, reaming, turning and engraving



Size	Part No.
14 AV OZ aerosol	9106
(pinpoint extension tube included)	
1 quart	9101
1 gallon	9102
5 gallon	9103

Buttercutt

Cutting Compound

Buttercutt stays put! Excellent for precision production needs. Minimizes tool sharpening even on spring steel and implement metals. High temperature, high pressure film strength.

Safe! Safe! Safe! A special fatty compound founded on natural lard oil binds Buttercutt to working edges. Biodegradable, non-hazardous... no solvents and no harmful vapors.

Applications: Boring, drilling, planing, milling, sawing, tapping and many other close tolerance operations.



Size	Part No.
1 pint	5040
1 gallon	5041
5 gallon	5042
55 gallon drum	5043

TFE Lubricant Permanent Film

Stays on the Surface! Non-Yellowing Resin Bonded, Self Polishing, Stays Put

Heavy duty protection and lubrication of all sliding surfaces. Forms a continuous, tough film and provides an extremely low coefficient of friction. Resists moisture and will not combine with process materials. Excellent for use where cleanliness and non-contamination are critical. Safe for metals, wood, rubber, leather, plastic, glass and painted products. Test on small area before using on plastic or paint.

Applications: Conveyor belts, machine tools, dies and locking mechanisms.



Size	Part No.
10.5 AV OZ. aerosol	6078

Dry Film

Lubricant & Mold Release Agent (TFE)

Clear... clean... dry Teflon* Formula - Clean, slippery, dry and invisible when applied. Lubricates without grease. Resistant to dirt and dust. Durable beyond normal lubricant breakdown... works up to 500° F.

Use where silicone, oil or wet lubricants can not be tolerated. Ideal for parts which are impractical to relubricate after assembly, such as electrical equipment, sealed cams and switches. Safe for rubber, wood and metals.

This is the lubricant which provides efficient protection well beyond normal break-in periods. Will not interfere with post finishing operations. Very effective under extreme dust conditions, such as encountered in mining and quarry operations.

Offers Excellent Adhesion And Durability.

- Non-staining
- Chemically Inert
- Reduces Clean-up Time

Applications: Electrical equipment, precision machines, survey instruments, industrial sewing machines, conveyors and chutes

*Dupont Trademark



Size	Part No.
10.5 AV OZ. aerosol	6075
1 gallon	6076

All-4

Moisture Displacing Lubricant Multi-purpose Problem Solver

all-4's unique formula combines the essential ingredients necessary to clean, lubricate and protect metal in a single product.

- Displaces Moisture
- Cleans and Penetrates
- Prevents Rust
- Lubricates
- Silicone Free
- Especially Effective in High Humidity

Applications: Bulbs and sockets, circuit breakers, cables, elevators, generators, ignition systems, lift trucks, coils and transformers.



Size	Part No.
12 AV OZ. aerosol	7340
1 gallon	7342
5 gallon	7343
55 gallon	7344

Penetrating Oil

Penetrates Metal Pores; Releases Rust Fast

Penetrates and loosens rust, tar, dirt, carbon and corrosion, even on stubborn, rusted bolts. Creeps into tight spaces.

- Reduces tugging and pounding
- Accurate, pinpoint control
- Only a few drops needed
- Effective against salt water corrosion
- Contains no acid
- Pinpoint extension tube included with each aerosol

Applications: Quick release for nuts, bolts, fittings, hinges & valves



Size	Part No.
11.2 AV OZ. aerosol	6030
1 quart	6026
1 gallon	6027
5 gallon	6031
55 gallon drum	6048

Lubricating Oil

General Purpose For Stocking Tool Cribs

Blend of oils which coats or lubricates rubbing surfaces with extremely close tolerances. Reduces wear and noise; protects sliding surfaces; waterproofs and rustproofs. Will not become brittle and has no unpleasant odor. Replaces the old messy oil can.

Applications: Slide bars, ball bearings, guides, drill chucks, door hinges and metal locks.

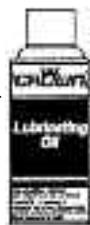

Size	Part No.
5 AV OZ. aerosol	6028

24
Maintenance
Repair
Operations

Crown

Food Grade Silicone Lubricant Special Purpose Lubricants for the Food Processing Industry

Authorized by USDA for use in federally inspected meat and poultry plants. Specifically developed for use near food processing. Has no odor, taste or color. Not a food additive, but safe where incidental contact may occur.

- No Chlorofluorocarbons
- Non-corrosive
- Non-toxic

Effective for wood, metal, most plastic or rubber. Lubricates a surface except those which need post-decorating.

Applications: Cams, conveyors, freezers, ovens, slides, rollers, and belts on food machinery.



Size	Part No.
10 AV OZ. aerosol	8036

Food Safe Lubricant Contains No Silicones

Authorized by USDA for use in federally inspected meat and poultry plants. Safe for machinery in close proximity to foods. Contains no chlorofluorocarbons. Reduces noise and wear where friction occurs. Penetrates surface and prevents sticking. Leaves no gummy residue. Contains aliphatic and naphthenic hydrocarbons (in the Federal Register of the FDA, paragraph CFR 178.3620, sub-paragraph 172.878) and propellant. Spray application is simple, clean and easy. The propellant flashes off in a few seconds, leaving a clear, slippery film that will not stain.

Applications: Grinders, belts, mixers, slides, conveyors and slicing machines, bakeries.



Size	Part No.
14 AV OZ. aerosol	6035

Silicone Lubricant - General Purpose Will Not Form Residues!

Lubricates from -100° F to 500° F without freezing or oxidizing. Coating withstands pressures less than 2,000 psi. Eliminates carbonaceous and lacquer deposits. Reduces friction and heat build-up.

Resists acids and alkalis. Moisture and oxidation resistance are excellent. Except for parts to be painted, it is safe for wood, nylon, metal, rubber, leather, canvas and chrome.

Applications: Precision instruments, gears, tools, wheels & locks.



Size	Part No.
10.5 AV OZ. aerosol, pinpoint extension tube included	8034
1 gallon	8028
5 gallon	8033
55 gallon drum	8032

Lithium Grease Excellent All-weather Protection for Moving Parts

Penetrates deep to form a protective film withstanding all loads and speeds. Effective both indoors and out in temperatures from -70° F to 360° F. Eliminates squeaks and squeals.

Applications: Gears, ball and roller bearings, speed reducers, cams, pumps, bolts and studs.



Size	Part No.
11 AV OZ. aerosol, pinpoint extension tube included	7037

Heavy Duty Open Gear and Wire Rope Lube

Tough and Pliable with Extra Adhesion

Lubricates As It Waterproofs - Superior mastic and wicking properties. Tough and pliable with superior adhesion. Penetrates deep into wire rope and cable, and reduces wear and noise. Foaming action insures total coverage.

Weather-Resistant - Withstands extreme temperature and pressure. Will not become brittle or break down under prolonged use. Dark color helps determine proper and uniform application.

Applications: Wire rope and open gears, fifth wheels on tractor trucks, screw threads, power take-offs, drive chains, die-set leader pins and flexible coupling



Size	Part No.
12 AV OZ. aerosol	7045

Moly Open Chain Lube Oil

Penetrates Deep Between Roller Chain Drive Bushings

Reduces the stress of start-ups and high temperature breakdowns.

Provides Critical Lubrication - Solvents drive deep into tight, inaccessible areas. Provides superior lubrication where high pressure or temperatures cause breakdowns of protective films.

Applications: Hoist chains, saws, conveyors, link and roller assemblies, chain drives and other equipment that calls for a high-grade light oil.



Size	Part No.
12.7 AV OZ. aerosol	7043

Moly Grease/Lift Truck Grease

Heavy Duty for Higher Temperatures - Provides longer periods of lubrication with less reapplication. Stays put where ordinary greases squeeze out under heavy loads or vibrations.

Waterproofs... Rustproofs

Coats and adheres to metal surfaces. Use with any equipment subjected to extra pressures. Withstands heat up to 450° F.

Applications: Gear boxes, drive chains, wire ropes, hoists, die-set leader pins and flexible couplings.



Size	Part No.
11 AV OZ. aerosol	7041

Dry Graphite Lubricant and Parting Compound

Temperature Range from -100° F to +1000° F

Used throughout the world for extreme temperature lubrication requirements. Coats surfaces with a super slippery, long-lasting protective film. Stops squeaking and sticking.

Slippery... Clean... Dry Non-Oily... Non-Staining

Use where petroleum products must be avoided. Contains no oils or moisture-based diluents.

Applications: Will not collect dirt or grime.

Lubricant: bearings, locks, oven parts, pre-assembly of moving parts, sliding windows and doors

Parting Compound: dies, sand cores, match plates, drawing extrusions, die casting, pewter molding

Coating Compound: Conductive materials, sealants.



Size	Part No.
12 AV OZ. aerosol	8078

24
Maintenance
Repair
Operations

Maintenance, Repair & Operations

Crown

Dry Moly Lubricant

Use for the Most Demanding Conditions

Performs at pressures up to 100,000 PSI and temperatures up to 700° F. This dry, molybdenum disulfide product contains no oils or moisture-based diluents.

Quick-drying Tight Adhesion

Forms a dry, thin black film imparting anti-friction and anti-seizure properties. Bonds to metal surfaces. Provides long-lasting, noise-reducing protection. Use where a dirt and grime-resistant lubricant is needed.

Applications: Grinding mills, crushers, mechanical presses, cams and slides



Size	Part No.
11.6 av. oz. aerosol	6080

PAINTS & INKS

Maintenance and Touch-Up Paints

22 Nonfading, Lead-free Colors

Heavy duty, industrial grade OSHA safety paints meet federal requirements. Quick and easy application. Provides uniform coverage on most surfaces. Dries fast.

Contains no Chlorofluorocarbons (CFC19)

Formulated to fight corrosion, a perfect bond to metal surfaces. Ideal for hard-to-reach areas.

Applications: Color marking of physical hazards, safety, firefighting and protective equipment, metal decks, storage tanks, farm machinery and off-shore equipment.



Size	Part No.
12 av. oz. aerosol	7103 to 7199

Meets OSHA Color Safety Coding Standards

Part No.	Color
7103	New Cat Yellow
7104	Alpine Green
7109	Tractor Green
7159*	Light Green
7160*	Red
7161	Dark Green
7162*	Yellow
7163	Dark Blue
7164*	Orange
7165	Light Blue
7166	Brown
7172*	Gloss White

Part No.	Color	(cont.)
7173*	Gloss Black	
7175	Aluminum	
7176	Silver	
7177	Gold	
7179	Flat White	
7180	Royal Blue	
7186	Dark Gray	
7190	Machine Tool Gray (ASA 33)	
7191	Flat Black	
7195	Dove Gray (ASA 61)	
7199*	Purple	

*OSHA Safety colors

Fluorescent Paint

Dazzling colors highlight hazards, get attention fast. Primer improves color intensity. Lasts indefinitely inside and up to two years outside.

Applications: Loading docks, fire escapes, hand rails, ladders, safety lanes, fire extinguishers



Size	Part No.	Color
11 av. oz. aerosol		
7201	Red	
7202	Green	
7203	Yellow-orange	
7206	Red-orange	

High Temperature Paint

TAKES THE HEAT! Two colors: Black (7221) withstands 500° to 800° F intermittent temperatures, aluminum (7222) withstands 1,000° to 1,500° F constant and up to 2,000° F intermittent. Dries tackfree in approximately 10 minutes

Applications: Exhaust stacks, oven parts, furnaces, heat exchangers, stoves, hot steel surfaces, radiators, etc.

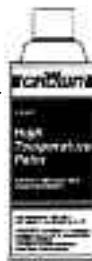

Size	Part No.
12 av. oz. aerosol (Black)	7221
12 av. oz. aerosol (Aluminum)	7222

Red Oxide Primer, Gray Primer

Sprays like a lacquer with no sags or runs. Fights corrosion and dries quickly.

Applications: Underground pipe, storage tanks and old machinery.



Size	Part No.
12 av. oz. aerosol (Red)	7212
12 av. oz. aerosol (Gray)	7219

Upside Down Paint

Save time as you mark pavement, construction sites, excavation areas and underground utility locations

- **No. 1240 Safety Red** - Marks electrical line locations
- **No. 1241 Caution Blue** - Marks water line locations
- **No. 1242 Safety Green** - Marks sewer line locations
- **No. 1243 Traffic Yellow** - Warns of gas and oil lines; also used for curb and pavement lane markings
- **No. 1244 Alert Orange** - Marks all types of communication transmission lines
- **No. 1245, White** - Marks recreational activity areas. Provides contrast on dark surfaces. Chosen by cable companies to prevent confusion with other utilities
- **No. 1246 Clear & No. 1247 Hot Pink** - Used to mark traffic hazards, obstructions, safety and parking lanes, underground utility locations, construction sites, highway accident scenes or any application where spraying upside down makes the job easier or faster.



Guideliner Applicator (No. 1239)

Enjoy professional results as you save time and energy with Crown's new Guideliner. Fully assembled and ready to use. Best of all, it's easy on your back!

Spra-Line Paints

For Economical Color Coding in 10 Vivid Colors

Specialty paints formulated for economy and ease when color coding stock and other materials. Lead-free... fast drying. Can be applied to almost any surface. Spra-line Paints resist corrosion and most chemicals.

Applications: Color coding stock and materials, grading lumber, spot-marking logs, pipe, steel and concrete

Size	Part No.	Color
11 av. oz. aerosol		
1201	Red	
1204	Dark Green	
1207	Yellow	
1212	Dark Blue	

Part No.	Color	(cont.)
1216	Orange	
1219	Gloss White	
1222	Gloss Black	
1227	Flat White	
1230	Machine Tool Gray	
1236	Flat Black	



Toolmaker's Ink

Precise Scribing without Chipping

Enables accurate scribing without glare. Produces quick-drying film that won't peel, flake or rub off. Contains no acids and resist heat.

Dries Quickly.

Suggested for dies, templates, tools and machined parts. Excellent adhesion to metal, glass and plastic. Removes easily with Crown's Toolmaker's Ink Remover. Available in blue (all sizes)

Applications: Patternmaking, model making and production layouts.

Size	Part No.
12 av. oz. aerosol can	6001
7.5 fl. oz. brush top	6015
1 quart	6017
1 gallon	6018



Toolmaker's Ink Remover

Dissolves All Layout Fluids

Special solvents remove inks without bothersome residues. Can also be used as a paint stripper. Safe and convenient aerosol application. Also available in non-aerosol bulk.

Size	Part No.
10.5 av. oz. aerosol	7001
1 quart	7003
1 gallon	7004
5 gallon	7005
55 gallon drum	7006



Crown

Stencil Ink

Crown's exclusive formula sprays evenly, dries less than 10 minutes. Sharp, permanent markings will not "bleed" under stencils.

This waterproof ink saves time and money; won't smear or smudge.

Size	
11 AV. OZ. aerosol.	
Part No.	Color
7080	Black
7081	Red
7082	Yellow
7083	White



CORROSION PREVENTATIVES

Cold Galvanizing Compound

- The best long-term rust protection you can buy
- 93% Zinc-rich coating is electrochemically fused to iron and steel
- Equal to hot dip galvanizing
- Aerosol will not clog or sputter

The longest-term rust prevention available. If the surface is scratched, an electrochemical reaction causes the zinc to sacrifice itself for the base metal's protection. This keeps corrosion off the protected surface. You will have no rust or rust creepage.

Incomparable Corrosion Prevention! Authorized by USDA for use in federally inspected meat and poultry plants.

Durable and Reliable. In an independent laboratory test, Cold Galvanizing Compound withstood over 2000 hours of salt-spray testing (Federal Test Standard No. 151a. Method 811 1.) Also, passed Preece Test for hot-dip galvanizing. Cold Galvanizing Compound is resin bonded and has a light gray, matte finish.

Simple Application. Cold Galvanizing Compound can be easily sprayed, brushed, or dipped onto any metal surface. Suggestions for application include welded joints, guard rails, bridges, damaged surfaces, fences, heat duct, storage tanks, pipe lines and offshore equipment.

Size	Part No.
14 oz. aerosol	7007
1/2 pint	7002
1 quart	7008
1 gallon	7009
5 gallons	7013

USDA approved for use in federally inspected meat and poultry plants. Bulk products meet Mil Specs: Mil-P-46105, Mil-P-21035, DOD-P-21035a.



Galva Bright Premium

Glistening zinc coating that will restore galvanized steel to the bright look of Hot Dip. Galva Bright will stop rust and corrosion on any iron or steel surface. It's zinc rich formula provides long lasting protection.

Applications: Cosmetic repair of welds, hand rails, rims, highway guard rails, metal chain fences, pipes, TV towers, refinery piping, corrugated metal buildings, heavy equipment, and anywhere the bright look of hot dipped surfaces is preferred.

Size	Part No.
13 AV. OZ. aerosol	7707
Quart	7708



Rust Inhibitor

Contains Fortified Lanolin for Moisture Absorption

Protects and lubricates indoor equipment such as tools, parts and machinery. Penetrates deep, absorbs moisture and neutralizes corrosive acids. Waxy, elastic film removes easily with any paint solvent.

Lasting Rust Protection

Applications: Twist drills, nuts and bolts, plow blades, pumps and machinery.

Size	Part No.
11 AV. OZ. aerosol	6007
1 gallon	6008
5 gallon	6009
55 gallon	6011



Formula 101 Corrosion Suppressant

Recommended for long, low-cost corrosion protection requirements. Petroleum based with excellent chemical resistance. Penetrates surface and forms transparent film that will last until you want it removed.

Applications: Construction equipment, bridgework, tanks, pipe, farm machinery, marine equipment and shipping deck cargo

Size	Part No.
10.5 AV. OZ. aerosol	6013
1 gallon	6032
5 gallon	6033
55 gallon drum	6043



Kleer Kote

Crystal Clear Acrylic Protects and Waterproofs

An excellent weatherproof and waterproofer. Provides lasting protection against wear, handling and oxidation—prevents bleaching or fading from sunlight as well as tarnishing. Resists salts, alkalis, weak acids, heat or cold. Adheres to metals, wood, and paper.

Covers and seals with a lustrous, smooth finish that makes most surfaces mar-resistant and chip-proof. Will not cause discoloration.

Has No Equal!

Dries quickly at room temperature. Becomes tacky at 35° F, but regains hardness upon cooling.

Applications: Brass fixtures, blueprints, tubing and machine parts.

Size	Part No.
12 AV. OZ. aerosol	6004



Vinyl Strippable Coating

Sprays On... Peels Off

Sprays a vinyl film and dries to a rubbery, protective coating. Clean-up requires no solvents—simply peel the coating off. Quick, clean protection from corrosion, dust, dirt and paint spray. Excellent for storage or shipping. Best when applied to smooth surfaces.

Not recommended for plastics or substrates in which ketones can cause solvent action in materials to be coated.

Peels Off in Sheets

Apply 2 or 3 coats 15 minutes apart for best results

Applications: Precision tools, castings, anodized aluminum, highly polished surfaces and lenses

Size	Part No.
11 AV. OZ. aerosol	8040



CLEANERS

All Purpose Cleaner

Contains Ammonia, Cuts Dirt Faster

Cleans and polishes in one application. Just spray lightly, allow foam to loosen dirt, wipe clean with a damp cloth.

Quickly dissolves soap scum, dirt, grease and grime. Unbeatable for cleaning tough granite surfaces.

Applications: Metal, stainless steel, tile, formica and wood

Size	Part No.
15 AV. OZ. aerosol	5055



Anti-Vandal Spray

Professional Strength

Removes stubborn graffiti quickly. Spray-on solvent cleans unwanted marks from spray paint, ink, crayon, rubber heel marks and others.

Say Good-bye to Graffiti

Safe for hard surfaces such as ceramic tile, brick, aluminum, steel, brass, chrome, vinyl and ceramics.

Applications: Signs, overpasses, restroom walls, sidewalks, bridges, buildings

Size	Part No.
14 AV. OZ. aerosol	5062



Maintenance, Repair & Operations

Crown

Emulsifiable Degreaser

Cleans As It Degreases

Removes grease, oil and other heavy solid quickly without damaging metals, paints or rubber. Dries fast; leaves no residues. Washes off with water.

Applications: Engines, tables, benches, walls, floors and exhaust hoods

Size	Part No.
12.5 AV.OZ. aerosol	7015



Heavy Duty Cleaner

A strong cleaner that contains no CFC's or chlorinated solvents. This product acts quickly, but stays on the surface long enough to attack and dissolve dirt and grease. Heavy Duty Cleaner/Degreaser can be used on alternators, bearings, pulleys, chains, cable connections, brakes, engines, power and air tools, forklifts, terminals, switches and other grimy surfaces. Safe on most plastics and metals. Always test on surface before using.

Size	Part No.
14 AV.OZ. aerosol	8260



Off-Line Contact Cleaner

An excellent contact cleaner that contains no CFC's or chlorinated solvents. It evaporates quickly, leaves no residue and has a low odor. Off-Line Contact Cleaner is very attractively priced. Because this product is flammable, it is intended to be used on equipment that is not in service. Use on relays, switches, contacts, circuit breakers, plugs and jacks, terminals, circuit boards, generators, electro-mechanical assemblies, fusible disconnects and some plastic conveying equipment. Safe on most plastics and metals. Always test on surface before using.

Size	Part No.
10.9 AV.OZ. aerosol	8276



Electronic Component Cleaner

Excellent to use on electronic components to flush away contaminants and film. It evaporates quickly, leaves no film or residue and has a low odor. Electronic Component Cleaner has No Flash Point. It can be used on relays, switches, contacts, circuit breakers, plugs, jacks, terminals, circuit boards, generators, electro-mechanical assemblies and fusible disconnects. Can also be used as a flux remover. Avoid use on certain plastics, including ABS, Acrylic and Styrene. Always test on surface before using.

Size	Part No.
16 AV.OZ. aerosol	8376



Safety Solvent

Dissolves Grease Fast, Leaves Surfaces Clean and Dry
Contains No CFC's
Contains No Class I or II O.D.C.'s

Dissolves heavy grease, oil, dirt, inks, paints, and sludge. Eliminates lubricant build-up. Provides sparkling clean metal surfaces. Prevents costly and dangerous flashovers. Acts faster than any petroleum solvent.

Fast Evaporation

Flash-off happens in seconds. Surfaces are clean and dry with no powdery or oily residues. Provides in-place cleaning of operating equipment. Also ideal for removing spots and fingerprints.

No Need to Wash or Flush

Requires no after-neutralization and no sticky film remains.

- Low Toxicity
- Non-Flammable
- Consistent Cleaning Power
- User/Workplace Friendly

Applications: Electric motors, lathes, mining equipment, grease fittings, molds, switches, generators, relays, brake linings, rheostats and fuse holders.

Note: Always test on plastic and other surfaces before using.

Size	Part No.
20 AV.OZ. aerosol, pinpoint extension tube included	8060
1 gallon	8061
5 gallon	8062
55 gallon	8064



MOLD RELEASES

Silicone Mold Release

Contains solvents, pure silicone and chemically inert propellant. Purity cuts rejects and reduces markings, spotting or sticking. Will not carbonize, melt, freeze or gum. Tenacious film resists breakdown under mechanical shear and heavy loads. Formulated for acrylics, cellulose, ABS resins, polystyrenes, polyesters, rubber and melamines. Safe for temperatures up to 500° F.

Part No.	Type	Size
3023	Regular	18.5 AV.OZ. aerosol
3123	Rapid	13 AV.OZ. aerosol
3223	Ready	18 AV.OZ. aerosol
3423	Reliable	13 AV.OZ. aerosol
3045	Regular Heavy Duty	18.5 AV.OZ. aerosol
3145	Rapid Heavy Duty	13 AV.OZ. aerosol
3245	Ready Heavy Duty	18 AV.OZ. aerosol
3445	Reliable Heavy Duty	13 AV.OZ. aerosol
3201	Ready	18.5 AV.OZ. aerosol



Epoxy Mold Release

Meets the needs of compression molders using all types of epoxy and phenolic resins, as well as producers of flexible and rigid polyurethane. Contains no silicones and is readily removed with industrial washers and cleaners usually employed prior to painting operation. Contains wax.

Size	Part No.
Regular 16 AV. OZ. aerosol	3070
Ready 17 AV. OZ. aerosol	3270
Reliable 13 AV. OZ. aerosol	3470



Food Safe Mold Release

Requires only a simple rinse for post molding decoration. Food Safe... does not contain silicones. Ideally suited for all polypropylene and polyurethane moldings, including toys, food containers and closures.

Size	Part No.
Ready 18 AV. OZ. aerosol	3280
Reliable 13 AV. OZ. aerosol	3480



SPECIALTIES

Wasp and Hornet Killer

- Kills wasps, hornets and yellow-jackets. Penetrates nest, cracks and crevices. High-pressure aerosol spray allows you to stay safely away from the nest.
- Deadly Accurate Jet Spray
- Lasting residual action prevents reinfestation for weeks. EPA Registered.
- Dielectric Strength Over 40,000 Volts Per centimeter!
- Provides safety when spraying near electrical wires.
- Improved Formula Does Not Harm Most Plastics.

Size	Part No.
15 AV.OZ. aerosol	5161



Drive Belt Dressing

- Increases Gripping and Pulling Power
- Prevents slippage of all types of flat, round, or v-belts.
- **Stops Squeaks and Squeals** - Softens gummed dirt, stops pulley Squeaks, and won't shrink or stiffen belts. Effective indoors and out.
- Will Not Collect Dust or Dirt.
- Helps preserve leather and rubber.

Applications: Compressors, pumps, conveyors, generators, fans and textile, automotive and farm equipment.

Size	Part No.
12 AV. OZ. aerosol	8079
Quart, Squirt Top Can	8046



Crown

Welder's Anti-Spatter

Eliminates bothersome clean-up! Makes welding easier and cleaner by reducing spatter cleaning problems. No. 8030 powder prevents spatter build-up on welding equipment. No. 8031 sprays on and spatter wipes off without causing post-decorating problems.

- Leaves the Surface Clean
- No Scraping
- No Wire-brushing
- Saves time and money in all welding operations
- * Spray inside nozzles of Mig, Tig and Tag Tips...They Last Longer



Size	Part No.
16 AV.OZ. powder aerosol	8030
12.6 AV.OZ. liquid aerosol	8031
1 gallon (liquid)	8026
5 gallon (liquid)	8025

FAULT FINDER

Dye Penetrant Inspection Systems

Group 1A (Inspection Kit 1010)

1. Cleaner - No. 1011
2. Penetrant - No. 1012
3. Developer - No. 1013

Conforms to MIL-1-25135. Active ingredients meet chlorine and sulfur requirements of NAVSHIPS 250-1500 and MIL STD 271.

Advantages of Groups 1 and 1A:

- Portability
- Accuracy
- Versatility
- Simplicity
- Availability
- and affords immediate results!

Group 1A is Certified Low in Chlorine and Sulfur-Bearing Solvents. Because of its carrier solvents, Group 1A is our least flammable system.



Product	8.5 av.oz. Part No.	1 gallon Part No.
Cleaner	1011	1024
Penetrant	1012	1014
Developer	1013	1017

Group 1 (Inspection Kit)

1. Cleaner - No. 1071
2. Penetrant - No. 1075
3. Developer - No. 1079

Contains No Chlorine or Sulfur-bearing Solvents.

It was developed specifically for testing materials where halogenated safety solvents are not permitted. This system meets the RDT F-3-6T standard as established by the Atomic Energy Commission. You'll see red if this system detects any faults.

Conforms To MIL-1-25135 Active ingredients meet chlorine and sulfur requirements of the RDT F-3-6T standard, NAVSHIPS 250-1500 and MIL STD 271.

Product	Part No.	Size
Cleaner	1071	7.5 AV. OZ.
Penetrant	1075	8.5 AV. OZ.
Developer	1079	7 AV. OZ.

Fully Portable Inspection Kits

Find cracks and other faults fast. Convenient spray cans make for an easy, no-waste application.

Crown® Products Give You a Choice:

- Group 1A Inspection Kit #1010
- Group 1 Inspection Kit #1070

Each kit is complete with convenient carrying case, instructions, 4 cans cleaner, 2 cans penetrant and 2 cans developer

Nondestructive Testing - Simple... Simple... Easy

1. Spray on cleaner and wipe off.
2. Spray on penetrant and allow time to set.
3. Wipe excess penetrant from surface with cleaner.
4. Spray on thin layer of white developer.
5. Visual inspection. Red cracks and other faults will appear in white developer area.



ELECTRICAL

Red Insulating Enamel

Hard Glossy Finish - Protects against moisture and corrosion. Forms a seal against dirt and grime. Air dries to a hard, glossy, flexible state providing excellent and high dielectric strength. Resists oils, acids, alkalies and chemicals.

Applications: Primer and finish, motor, generator, transformer bearings, anti-moisture coating, thermostat, water cooler insulation, coils, armatures sealer, concrete floors, pipe threads, vacuum system

Size	Part No.
13 AV.OZ. aerosol	6086



Red Insulating Varnish

Protects With Outstanding Adhesion - Dries to a flexible, tough, oil-proof film that protects electrical equipment. Highly resistant to acids, alkalies, oils, moisture and heat and strongly adheres to metal and insulating components. It has a dielectric strength of 1200 V/MIL wet, 2100 V/MIL dry (ASTM).

Applications: Armature and stator windings, high voltage circuits, commutator ends, coils... to protect leads, to coat frayed insulation, and to restore dielectric properties lost from frictional wear or corrosion.

Size	Part No.
13 AV. oz. aerosol	6084



Electrical 88

Displaces Moisture - Hydrophobic action lifts moisture from surfaces effectively drying mechanical parts and electrical systems. Penetrates and acts as a light lubricant. Silicone-free. Non-gummy, non-sticky.

Protects Against Rust - Acts as an excellent rust inhibitor for up to one year outside and two years inside storage.

Applications: Moisture-proofing electrical equipment, motors, solenoids, controls, terminals, capacitors, transformers, fuse boxes, switches, and switch gears, multiple connectors, ignition systems and welding equipment.

Size	Part No.
14 AV.OZ. aerosol	8070



Off Line Contact Cleaner

An excellent cleaner that contains no CFC's or chlorinated solvents. It evaporates quickly, leaves no residue and has a low odor.

Applications: Use on relays, switches, contacts, circuit breakers, plugs and jacks, terminals, circuit boards, generators, electromechanical assemblies, fusible disconnects and some plastic conveying equipment. Safe on most plastics and metals. Always test on surface before using.

Size	Part No.
10.9 AV.OZ. Aerosol	8276



Battery Terminal Coating

Airtight and Waterproof

Protects against leaking, acid and corrosion. Provides a visible (yellow) airtight and waterproof insulation. Guards against current loss and prolongs life. Resists gasoline, oil and heat. Will not crack or peel.

Applications: Connections or other electrical installations

Size	Part No.
12 AV.OZ. aerosol	6005



Maintenance, Repair & Operations

Crown/General Chemical

Heavy Duty Permanent Adhesive

Aggressive holding power! A super-tough formula that holds heavier objects with a strong, instant grip. For those that require more, coat both surfaces. High shear and peel strength with good initial grab.

Applications: Wood, paper, glass, plastics, vinyl used by asbestos abatement contractors.



Size	Part No.
11.57 Av.Oz. aerosol	8091

General Purpose Adhesive

Just spray on and press into place. Saves time. Sticks to most any surface-rough or smooth. Adheres to paper, fabric, plastic, lightweight metal pieces without mess or waste. Permits sufficient time to position materials.

The Ideal Adhesive for Light Production Work - Temporary pinning alignment of parts for final assembly.



Size	Part No.
11.0 Av.Oz. aerosol	8090

Spray Contact Adhesive

Provides strong contact bond quickly, one minute dry time for most materials, up to 3 minutes for laminates. Stands up to high temperatures, 220°F. Permanently affixes flexible materials, such as laminates and many plastics, to metal, wood and other rigid surfaces. Not recommended for vinyls.

Applications: Used extensively in auto trim applications and van conversions, cabinet shops and manufacturing assembly operations.



Size	Part No.
17.0 Av.Oz. aerosol	8192

General Chemical

FLAKE CALCIUM CHLORIDE

**CALCIUM CHLORIDE
VERSUS
COMPETITIVE DEICERS ALONE**

Rock Salt (Sodium Chloride)

- has substantially diminished effectiveness below 25°F (-4°C). The amount of ice melted per pound of rock salt drops 61% from 30°F to 25°F.
- melts less ice in a given time period.
- has slower melting action.
- bounces and scatters off road (typically 30%)
- has environmentally-negative impact.

Sand and/or Abrasives

- do not melt ice and snow, just provides *some* traction.
- bounces and scatters off road.
- requires clean-up.

Rock Salt and Sand/Abrasives Combined

- offer less melting performance over rock salt alone.

General Chemical

Melts more ice than other deicers

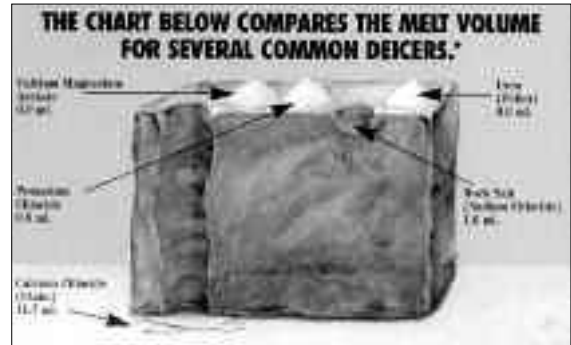

All deicers need moisture to dissolve and become effective. Because flake calcium chloride is hygroscopic, it draws this needed moisture from the air and ice itself. This allows flake calcium chloride to work under conditions that render other deicers ineffective. Plus, flake calcium chloride produces an exothermic reaction as it works, giving off heat - so it works quicker and melts more ice, at lower temperatures than any other deicer... down to -25°F!

Speedy Dry Granular Sorbent

- The original clay sweep and dry absorbent product
 - Used for the cleanup of oils, motor oils, greases, solvents, water, acids, paints, inks, chemicals and other liquids
 - Packaged in 50 lb bags
- Note: Contaminated product must be disposed of in accordance with applicable federal state and local regulations*



Floor sweeping Compound

Recommended for use on polished and all fine floors of asphalt, tile and linoleum. Also used light to medium sweeping of concrete warehouse floors. The Green Abrasive is oil-based and recommended for heavy-duty cleaning situations. The Red Wax base is non-abrasive for cleaning and polishing hardwood floors.



Weiler Brushes

Weiler Brushes

Floor Brooms - Plastic

No.	Head Size or Item (in)	Filling Material
42035	18	Black Plastic
42037	24	Black Plastic
2PP30	30	Black Plastic
42095	36	Black Plastic



Garage Brooms - Palmyra

No.	Head Size or Item (in)	Filling Material
42023	24	Palmyra
42138	36	Palmyra
42022	18	Palmyra



Street Broom

No.	Head Size or Item (in)	Filling Material
2RD18	18	Green Poly
2RD24	24	Green Poly
2RD16	16	Blue Poly
1SN18	18	Brown Poly



Counter Dusters

No.	Head Size or Item (in)	Filling Material
11HPL8	9	Horsehair-Tampico-Plastic Mix



Truck Brush

No.	Head Size or Item (in)	Filling Material
44510	9.5 x 2.75	Polystyrene



Dairy & Auto (Pot)

No.	Head Size or Item (in)	Filling Material
44017	20	Tampico



Mill & Warehouse Brooms - (Excellent Quality)

(Wire Band for Extra Reinforcement)

No.	Filling Material
70308	All Corn (35 lb.)



Whisk Brooms

No.	Head Size or Item (in)	Filling Material
275	10"	All Corn

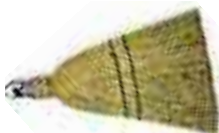

Janitor Dust Pans – Metal - Black Enamel

No.	Head Size or Item (in)	Filling Material
71078	12" Wide	Heavy Gauge Steel



Parts Cleaning Brush

No.	Head Size or Item (in)	Filling Material
40035	2.5 x 1.25	Nylon



Wet Mops

No.	Head Size or Item (oz)	Filling Material
75104	24	8 ply cotton
75105	32	8 ply cotton



Wet Mops Handles - Metal Frame

No.	Head Size or Item	Filling Material
75131	Screw Type Sr.	w/54" Wood Hdl.
75132	Spring Type Sr.	w/54" Wood Hdl.



Squeegees

Heavy Duty, 4-Way Reversible for long life

No.	Head Size or Item (in)	Filling Material
Floor, Metal		
45507	24	Black Rubber
75202	36	Black Rubber
45534	30	Black Rubber
Floor, Metal CURVED		
45511	36	Black Rubber
45535	30	Black Rubber



Broom Handles

No.	Head Size or Item	Filling Material
Street Broom		
44020	60	Lacquered Wood
Heavy Duty Handle		
44300	60	Metal Thread
Extension Handles - Fiberglass		
STR-SE48	4' - 8'	Extension Handle



Wire Scratch Brushes

No.	Head Size or Item	Filling Material
25154	3 x 19 Rows	Wire



Paint Brushes

No.	Head Size or Item (in)	Filling Material
40179	1 x 5/16	White Bristle
40180	1-1/2 x 5/16	White Bristle
40181	2 x 5/16	White Bristle
40182	2-1/2 x 3/8	White Bristle
40183	3 x 3/8	White Bristle
40184	4 x 4/8	White Bristle



Handle Braces

No.	Description
44290	Wide Angle
A-807	Broom Brace



Maintenance, Repair & Operations

Your One-Stop-Shop



CUSTOM FABRICATION

Can't seem to find anything "off the shelf" that fits your rigging needs? Custom sling fabrication is where we shine! We can custom design wire rope, chain, or synthetic slings to fulfill your most challenging requirements. We offer wire rope single part slings up to and including 3" diameter.



RENTALS

Hanes Supply offers a large inventory of rental tools and equipment ready to be picked up or delivered to your job site. Whether you are in need of individual products, or you are looking to save on a **complete equipment package** to be rented for a particular job, our rental department has the tools you need.



REPAIR SERVICES

Hanes Supply is an authorized warranty center with factory authorized/certified technicians. Quality workmanship and great customer service are our top priorities! We can service and repair electric tools, hydraulic and pneumatic tools, hoists, winches, small engines, slings and more!



FIELD SUPPORT

We offer **24/7/365** field support when and where you need it. Emergencies happen from time to time. We will come to your aid in those tight deadline situations, even if it's outside of the normal 9-5 work week. Rely on HSI to keep your project moving forward and on time.



INSPECTIONS

Our trained and experienced rigging and fall protection experts offer inspection services for all of your wire rope, chain, synthetic slings, rigging hardware and fall protection gear. Our inspection teams provide written records of our inspections to comply with the ASME B30.9 Standard.



FIRE EXTINGUISHER SERVICES & SALES

Our full-service, mobile fire shop will come to you! *(Buffalo and Rochester, NY areas only)*. Services include annual and monthly extinguisher inspections, maintenance and repair, recharges, hydro-testing as well as safety training with live burn demos.



TESTING & CERTIFICATION

HSI offers proof and destructive load testing up to **600,000 lbs.** including cycle loading. Testing comes complete with certifications. Additionally, we also offer magnetic particle testing as well as gas monitor calibrations and respirator fit testing services.

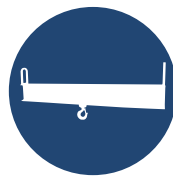

BELOW-THE-HOOK LIFTING DEVICES

Full support from Engineered Lifting Technologies (eltlift.com) - Offering **stock and custom lifters** including lifting and spreader beams, coil handling hooks, forklift attachments, best-in-class man baskets, and more.



PROUD MEMBER OF WORLD-CLASS ORGANIZATIONS

Our strength is built on our relationships with industry leaders, enabling us to deliver world class service that you can count on. Put your trust in the experience and expertise of HSI.



LA-CO® - Markal®

LA-CO® - Markal®

MARKERS & HOLDERS

Paintstick® Markers:

B Paintstick® Marker

Marks on Any Material, Surface or Texture

- Real paint in stick form.
- Weather-resistant, UV-resistant.
- Ideal for layout, color coding, fabrication and identification.
- Marks through oil and water
- Marks on smooth, rough, rusty or dirty surfaces.
- For use on metal, wood, plastic, concrete, rubber, glass, cardboard and paper
- Lead-free, non-toxic.
- Available In 3 sizes.
- B & B-1" Unit packaging: 12 of one color to a box.
- B-3/8" Unit packaging: 36 of one color to a box



Size:
11/16" x 4-3/4"
Marking Range:
-50°F to 150°F

Part No.	Color	Part No.	Color	Part No.	Color
Std. Size					
84810	White	84833	Aluminum	80200	White
84813	Black	80220	White	80201	Yellow
84811	Yellow	80221	Yellow	B-3/8" Paintstick®	
84812	Red	80222	Red	80420	White
84814	Orange	80223	Black	80421	Yellow
84815	Blue	80224	Orange	80422	Red
84816	Green	80225	Blue	80423	Black
84817	Pink	80226	Green	80424	Orange
84818	Purple	90227	Pink	80425	Blue
84819	Brown	80228	Purple	80426	Green
84830	Gray	80229	Brown	B-1" Paintstick®	
84831	Flur.Yellow	80230	Gray	80260	White
84832	Gold	80231	Gold	80261	Yellow
		80232	Aluminum		
		82821	Flur.Yellow		

B-E Paintstick® Marker

For Marking Very Rough Surfaces

- Real paint in stick form.
- For marking forgings, castings, rough logs, lumber, concrete and other rough surfaces.
- Marks will withstand prolonged immersion in water.
- Lead-free, non-toxic.
- Long lasting, weather-resistant, fade-resistant.
- Unit packaging: 12 of one color to a box.



Part No.	Color	Part No.	Color
80620	White	80624	Orange
80621	Yellow	80625	Blue
80622	Red	80626	Green
80623	Black		

Size:
11/16" x 4-3/4"
Marking Range:
-50°F to 150°F

BL Paintstick® Marker

Bleeds Through Solvent-Based Paints

- Real paint in stick form.
- Marks bleed through solvent or oil-based paints.
- For fabricating structural steel, or layout work where the marks are required to bleed through a primer coat covering the marks.
- To prevent bleeding through the finish coat, seal the marked areas with water-based epoxy paint.
- For marking under water-based primers use the BL-W Paintstick®.
- Unit packaging: 12 to a box.



Part No.	Color
80725	Blue
84834	Blue

Size:
11/16" x 4-3/4"
Marking Range:
-50°F to 150°F

BL-W Paintstick® Marker

Bleeds Through Water-Based Paints

- Real paint in stick form.
- Marks bleed through water-based paints.
- For fabricating structural steel or layout work where the marks are required to be seen through the primer coat covering the marks.
- For marking under solvent or oil-based primers use the BL Paintstick.
- Unit packaging: 12 to a box.

Part No.	Color
84835	Blue
80735	Blue



Size:
11/16" x 4-3/4"
Marking Range:
-50°F to 150°F

C Paintstick® Marker

For Marking on Smooth Surfaces

- Real paint in stick form.
- For marking on smooth surfaces such as: cold rolled steel, sheet metal, plate glass and plastic.
- Long-lasting, weather-resistant, fade-resistant.
- Unit packaging: 12 of one color to, a box.



Part No.	Color
80820	White
80821	Yellow
80822	Red

Part No.	Color
80823	Black
80825	Blue

Size:
11/16" x 4-3/4"
Marking Range:
0°F to 150°F

E Paintstick® Marker

For High Visibility Marks

- Real paint in stick form.
- High intensity colors.
- For greater visibility in dimly lit areas.
- For coding, identification, layout and fabricating work.
- Long-lasting, weather-resistant, fade-resistant.
- Available in regular and king size.
- Unit packaging: 12 of one color to a box



Part No.	Color
Std. Size	
84840	White
84841	Yellow
84844	Orange
84845	Blue
88620	White

Part No.	Color
88621	Yellow
88624	Orange
88625	Blue
E-1" Paintstick®	
88640	White
88641	Yellow

Size:
11/16" x 4-3/4"
& 1" x 4-3/4"
Marking Range:
-50°F to 150°F

F Paintstick® Fluorescent Marker

All Purpose Fluorescent Marker

- Real paint in stick form.
- Ultra high visibility fluorescent colors.
- For marking metal, wood, glass, plastic, concrete, rubber, cardboard and paper.
- Marks through oil and water.
- Ideal for layout, inspection, and color coding.
- Unit packaging: 12 of one color to a box.



Part No.	Color
82831	Yellow
82832	Red
82834	Orange

Part No.	Color
82835	Blue
82836	Green
82842	Pink

Size:
11/16" x 4-3/4"
Marking Range:
-50°F to 150°F

Fast Dry Paintstick® Marker

Dries in 5 Minutes

- Paint in stick form.
- Marks dry in 5 minutes.
- Ideal for marking in fabricating shops and assembly lines where immediate handling is necessary.
- For marking metal, wood, glass, plastic, concrete, rubber, cardboard and paper.
- 3/8" site for marking smaller items.
- Unit packaging: 12 of one color to a box.



Part No.	Color
Std. Size	
82720	White
82721	Yellow
82722	Red
82723	Black

Part No.	Color
3/8" Size	
82730	White
82731	Yellow

Size:
11/16" x 4-3/4"
& 3/8" x 4-1/4"
Marking Range:
-50°F to 150°F

Maintenance, Repair & Operations

LA-CO® - Markal®

M & M-10 Paintstick® Markers

Marks Annealed, Normalized & Heat Treated Surfaces

- Real paint in stick form.
- Marks withstand annealing and heat treating operations.
- For welds, ingots, castings, forgings and annealed parts.
- Will not come off in oil or water baths.
- Unit packaging: 12 of one color to a box.

Part No.	Color	Part No.	Color
Std. Size		M-10 Paintstick®	
81920	White	82020	White
81921	Yellow		
81922	Red		
81923	Black		



Size:
11/16" x 4-3/4"
Mark at room temp.
M withstands 1600°F
M-10 withstands 1800°F

N Paintstick® Marker

Marks Will Not Show Through Top Coat

- Real paint in stick form, dries overnight.
- Marks will not show through top coat of primer or finish layer of paint.
- Ideal for shipbuilding or other metal fabrication that will be given a final coat of paint.
- For marking metal, wood, glass, plastic, concrete, rubber, cardboard and paper.
- Unit packaging: 12 of one color to a box.

Part No.	Color	Part No.	Color
82120	White	82122	Red
82121	Yellow	82123	Black



Size:
11/16" x 4-3/4"
Marking Range:
0°F to 150°F

O-10 Paintstick® Marker

Marks Heavily Oiled Surfaces

- Real Paint in stick form, dries overnight.
- For marking heavily oiled cold rolled steel and other oily surfaces.
- Unit packaging: 12 to a box.

Part No.	Color
82220	White



Size:
11/16" x 4-3/4"
Marking Range:
0°F to 250°F

HOT SURFACE PAINTSTICK® MARKERS:

H Paintstick® Marker

- Real paint in stick form.
- Bright colors for higher visibility.
- Mark hot coils, billets, slabs, bars, ingots, etc.
- Marks will not run, char, discolor, peel or crack.
- Marks are weather and fade-resistant.
- Unit packaging: 144 of a single color to a case.

Part No.	Color	Part No.	Color
81020	White	81025	Blue
81021	Yellow	81026	Green
81022	Red	81029	Brown
81023	Black		



Size:
3/8" x 4-5/8"
Marking Range:
150°F to 1200°F

HT Paintstick® Marker

- Real paint in stick form.
- Bright colors for higher visibility.
- Mark very hot coils, billets, slabs, bars, ingots, etc.
- Marks will not run, char, discolor, peel or crack.
- Marks are weather and fade-resistant.
- Available in two sizes, regular and king size.
- HT Unit packaging: 144 of a single color to a case plus I-# 100 holder.

Part No.	Color	Part No.	Color
Std. Size		King size	
81220	White	81225	Blue
81221	Yellow	81226	Green
81222	Red		
81223	Black	81210	White



Size:
3/8" x 4-1/2" Std.
3/4" x 4-5/8" King Size
Marking Range:
250°F to 1600°F

HT-34 Paintstick® Marker

- Real paint in stick form.
- Bright colors for higher visibility.
- Mark very hot coils, billets, slabs, bars, ingots, etc.
- Marks will not run, char, discolor, peel or crack.
- Marks are weather and fade-resistant.
- Available in two sizes, regular and king size.
- HT Unit packaging: 144 of a single color to a case plus I-#100 holder.

Part No.	Color	Part No.	Color
Std. Size		King Size	
84720	White	84710	White

Size:
3/8" x 4-1/2" Std.
3/4" x 4-5/8" King Size
Marking Range:
400°F to 1800°F

HT-40 Paintstick® Marker

- Real paint in stick form.
- Bright colors for higher visibility.
- Mark very hot coils, billets, slabs, bars, ingots, etc.
- Marks will not run, char, discolor, peel or crack.
- Marks are weather and fade-resistant.
- Available in two sizes, regular and king size.
- Unit packaging: 144 to a case plus I-#100 holder.

Part No.	Color	Part No.	Color
Std. Size		King Size	
84730	White	81610	White

Size:
3/8" x 4-1/2" Std.
3/4" x 4-5/8" King Size
Marking Range:
250°F to 1700°F

HT-75 Paintstick® Marker

- Real paint in stick form.
- Bright colors for higher visibility.
- Mark aluminum, steel, hot rubber, etc.
- Marks are weather and fade resistant.
- Makes broad, highly visible marks.
- Unit packaging: 12 to a box.

Part No.	Color
84820	White



Size:
3/4" x 4-5/8"
Marking Range:
150°F to 1000°F

J Paintstick® Marker

- Real paint in stick form.
- Bright colors for higher visibility.
- For foundries and mills where extreme temperature variance is encountered.
- Marks on surfaces subject to wide temperature variances.
- Marks will not run, char, discolor, peel or crack.
- Unit packaging: 144 of a single color to a case plus I-#100 holder.

Part No.	Color
81720	White
81721	Yellow

Size:
3/8" x 4-5/8"
Marking Range:
120°F to 600°F

K Paintstick® Marker

- Real paint in stick form.
- Marks on red hot steel.
- Marks will not run, char, discolor, peel or crack.
- Marks iron and steel castings, ingots, forgings, blooms, billets and high temperature metal alloys.
- Unit packaging: 12 to a box.

Part No.	Color
81820	White



Size:
3/4" x 4-5/8"
Marking Range:
1400°F to 2200°F

X-5 Paintstick® Marker

- Real paint in stick form.
- Marks on surfaces subject to wide temperature variances.
- Marks will not run, char, discolor, peel or crack.
- Marks on hot slabs, rough castings, ingots, forgings and rough surfaces that encounter wide temperature variations.
- Bright colors for higher visibility.
- Unit packaging: 144 of a single color to a case.

Part No.	Color
82520	White
82521	Yellow

Size:
3/8" x 4-1/2"
Marking Range:
150°F to 900°F

24
Maintenance
Repair
Operations

LA-CO® - Markal®

FIBER TIP MARKERS:

Dura-Ink® #15 Marker

Fine Tip

- Ideal for fine line marking.
- Extra tough tip, won't spread or mush.
- Smear-resistant, water-resistant fast-drying.
- Marks on metal, wood, cardboard, paper, plastic, glass, etc.
- For identification of parts, layout work, and marking cartons and crates.
- Available on blister card for point-of-purchase display.
- Meets U.S. Fed. Spec. TT-1-544.
- Unit packaging: 12 of one color to a box.



Part No.	Color	Part No.	Color
96021	Yellow	96026	Green
96022	Red	96028	Purple
96023	Black	96029	Brown
96024	Orange	96030	Black ²
96025	Blue	96033	Black ¹

Dura-Ink® #25 Marker

King Size

- Chisel tip makes fine lines or broad marks.
- Extra large ink supply for greater mileage.
- Heavy duty metal barrel.
- Use on cardboard, wood, metal, paper, ceramics, glass, and leather.
- For identification of equipment, marking shipping cartons and sign making.
- Meets Fed. Spec. TT-1-544.
- Unit packaging: 12 of one color to a box.



Part No.	Color	Part No.	Color
96221	Yellow	96225	Blue
96222	Red	96226	Green
96223	Black	96229	Brown
96224	Orange	96223	Black ¹

Dura-Ink® #50 Marker

- High intensity colors.
- Long mileage.
- Smear-resistant, water-resistant, fast-drying.
- Tough cap and plastic barrel for industrial use.
- Use for cardboard, ceramics, glass, leather, lumber, paper, rubber, steel.
- Unit packaging: 12 of one color to a box.



Part No.	Color	Part No.	Color
96522	Red	96525	Blue
96523	Black	96526	Green

LIQUID PAINT MARKERS:

Ball Paint Marker™

- Marks with real paint, dries in 5 minutes
- Durable metal ball tip marks on smooth or rough surfaces.
- Marks on metal, wood, plastic, glass, any hard surface.
- Lead-free, non-toxic.
- Marks are weather and fade-resistant
- Unbreakable plastic bottle with 1/8" steel ball tip.
- Stores in pocket for easy access.
- Plastic cap keeps tip clean between jobs.
- Unit packaging: 12 of one color to a box.



Marking Range:
-50°F to 150°F

Part No.	Color	Part No.	Color
84600	White ¹	84624	Orange
84601	Yellow ¹	84625	Blue
84620	White	84626	Green
84621	Yellow	84627	Fluorescent Pink
84622	Red		
84623	Black		

Valve Action™ Paint Marker

- Marks with real paint, dries in 3 minutes.
- Valve action nib releases paint as needed for continuous marking.
- Marks on all surfaces including: metal, wood, glass, plastic, rubber, cardboard and paper.
- Lead-free, low halogens.
- The fiber nib is replaceable to assure complete use of each marker.
- Durable metal barrel.
- Meets California VOC Regulations.
- Unit packaging- 12 of one color to a box.
- Assorted includes 8 white, 8 yellow, 4 red and 4 black.



Marking Range:
-50°F to 150°F

Part No.	Color	Part No.	Color	Part No.	Color
Bulk		96832	Aluminum Lt. Blue	Display Packs	
96809	Brown	96835		96810	White
96817	Purple	Carded - I/Card		96811	Yellow
96820	White	96800	White	96812	Red
96821	Yellow	96801	Yellow	96813	Black
96822	Red	96802	Red	96814	Orange
96823	Black	96803	Black	96815	Blue
96824	Orange	96804	Aluminum	96816	Green
96825	Blue	96805	Blue	96818	Aluminum
96826	Green	96806	Green	96819	Assorted ²
96827	Gold	96807	Orange	Tips	
				96867	Replacement Tips

CHALK:

Railroad Chalk

- Ideal for making temporary marks on most surfaces.
- Marks on metal, wood, concrete, cardboard, rubber, plastic, plus much more.
- The easy-to-hold 4" x 1" tapered shape makes broad, easy-to-read marks.
- Unit packaging: 144 per box. Packed 4 one gross boxes per case to prevent breakage during shipping. No broken cases are allowed on this product.

Part No.	Color	Part No.	Color
80500	White	80505	Blue
80501	Yellow	80506	Green
80502	Red		



Size: 1" x 4"

PENCILS:

Carpenter Pencil

- Available in three different leads.
- Premium quality.
- Flat lead design for easier marking.
- Makes clean, accurate marks on wood and other surfaces.
- Unit packaging: 12 per sleeve.



Length: 7"

Part No.	Color	Part No.	Color
96927	Hard Lead	96929	Soft Lead
96928	Med. Lead	96930	Med. Lead ¹

SOAPSTONE:

Soapstone Markers

- For the temporary marking of metal surfaces during welding and fabrication.
- Made of all natural soapstone for superior marking.
- Marks will not contaminate welds and are easily removed.
- Available in flat, round and square shapes. Holders available for the flat and round sizes.
- Soapstone is packed 3 one gross boxes per case to prevent breakage during shipping. No broken cases are allowed on these products.

Part No.	Size (in)
80129	5" x 1/2" x 3/16" flat
80130	5" x 1/4" round
80131	5" x 1/4" x 1/4" square



Maintenance, Repair & Operations

LA-CO® - Markal®

CRAYONS:

Lumber Crayon #500

- Also known as layout chalk or "keel"
- Longer lasting than ordinary crayons.
- Makes weather-resistant, water-resistant marks.
- Lead-free.
- Marks on concrete, wood, metal, plastic, rubber, paper, cardboard and ceramics.
- Fluorescent colors work well with computerized cut-off saws.
- Standard 1/2" hex shape fits the #109 Peterson holder, #106 holder and #108 holder.
- Other colors available on request
- Unit packaging: 12 of one color to a box.



Size:
1/2" x 4-5/8"
Marking Range:
-50°F to 150°F

Part No.	Color	Part No.	Color	Part No.	Color
Std. Colors					
84850	White	80322	Red	80341	Yellow
84851	Yellow	80323	Black	80342	Red
84852	Red	80324	Orange	80343	Black
84853	Black	80325	Blue	80345	Blue
84854	Orange	80326	Green	Fluorescent Colors	
84855	Blue	80327	Pink	80451	Yellow
84856	Green	80328	Purple	80452	Red
84857	Pink	80329	Brown	80454	Orange
84858	Purple	80332	Aluminum	80455	Blue
84859	Brown	80339	Terra Cotta	80456	Green
84860	Aluminum	Soft Grade		80462	Pink
85861	Terra Cotta	84881	Yellow	King Size	
80320	White	84882	Red	80371	Yellow
80321	Yellow	84883	Black		
		84885	Blue		

PLUMBING & PIPING SUPPLIES

FLUXES:

F-A-S-T 50/50 & 95/5

Flux & Solder Combination

- Premium grade of flux and solder combination.
- Combines virgin 50/50 or 95/5 finely powdered solder with LA-CO® Regular Flux Paste.
- Non-acid, contains no zinc chloride.
- Clean, leaves no black residue to obscure the soldering operation.
- 95/5 lead-free, non-toxic, safe for potable water systems.
- 50/50 contains lead, do not use on potable water systems.



Part No.	Color	Part No.	Color
50/50			
32003	3 oz. ²	31206	1/2 lb.
32006	1/2 lb.	32706	1/2 lb.
32007	1 lb.	32707	1 lb.
32033	3 lb.		

Aluminum Solder #60

- Use with LA-CO® Aluminum Flux Paste.
- Low temperature.
- High tensile strength.
- Stronger than ordinary solders.
- Resists galvanic action on aluminum.
- Melting point 390°F



Part No.	Size (lb)
36404	1/4 lb.

HOLDERS:

#101 Holder

5" Metal holder for Paintstik® markers: B, B-E, BL-W, C, E, N, O-10, P, BL, M, M-10.



Length: 4-3/4"

Part No.	Color
85000	#101

#108 Holder

- For all 1/2" hexagonal markers.
- Durable aluminum construction.
- Push-button operation.
- Protects crayon from breakage.
- Comes with leather wrist thong.
- 2' and 3' extensions available on special order.



Length: 6"

Part No.	Color
85400	#108
85410	w/2' extension
85420	w/3' extension

#110 Holder

- (Formerly #200) 11" Push-button wooden holder for hot surface markers: H, H-T, HT-25, HT-34, HT-40, J, X-5 Paintstick® markers.
- 3' extension available on special order.



Length: 13"

Part No.	Color
85600	#110
85610	w/3' extension

Soapstone Holders

- All metal construction for long work life.
- Prevents breakage.
- Allows fill use of each soapstone marker.
- Handy pocket clip.



Length: Flat - 5-3/4"
Round - 5-1/4"

Part No.	Desc.
80140	Flat for 5" x 1/2" x 3/16" size
80141	Round for 5" x 1/4" size

Silver Brazing Flux Paste

- Powerful cleaning action reduces waste of expensive silver solders.
- Packed in break-resistant plastic jars.
- Use with torch, furnace, resistance or induction heating
- Production sizes available,
- Meets Mil. Spec. MIL-F-4883.
- Certified by NSF to meet ANSI/NSF Std. 61 for use on potable water.
- Temperature range: 1000°F to 1700°.



Part No.	Size	Part No.	Size
22302	2 oz. ¹	22308	5 lb.
22305	6 oz.	22317	30 lb.
22395	6 oz. ³	22319	60 lb.
22307	1 lb.		

Certified to ANSI/NSF Std. 61

THREAD SEALANTS:

SLIC-TITE® Paste with Teflon*

Heavy-Duty Thread Sealing Compound

- Contains more Teflon* particles for greater sealing power.
- Use on metal, PVC, CPVC and ABS plastic pipe threads.
- For sealing water, air, steam, natural gas, LP gas, refrigerants, ammonia, gasoline, and oil.
- Do not use on Oxygen service, use Teflon* Tape or Oxytite® Paste.
- Washes off hands and clothing easily.
- Non-toxic, non-drying.
- Sealing temperature range: -50°F to 500°F.
- Working Pressures: 3,000 PSI for Gas, 10,000 PSI for liquids.
- USDA approved for use in federally inspected meat and poultry plants.



Part No.	Size	Part No.	Size
41209	1/4 pt. ³	42029	1 pt. ⁴
41219	1/2 pt. ⁴	42013	1 qt.
42002	1-1/2 oz. ⁵	42049	1 qt. ⁴
42009	1/4 pt. ⁴	42014	1 gal.
42019	1/2 pt. ⁴	42015	5 gal.
42012	1 pt.	42069	55 gal

24
Maintenance
Repair
Operations

LA-CO® - Markal®

Pipe Thread Tape of Teflon*

Standard Grade

- Thickness-3 mils.
- Standard grade, low density.
- Provides a highly resistant seal on pipe threads for all types of service.
- Suitable for use with solvents, chemicals, oxygen and on food lines.
- Non-toxic.
- Permits easy disassembly, even after years of service.
- Meets Mil. Spec T-27730A.
- Sealing temperature range: -450°F to 550°F.
- Pressures: to 2000 PSI.



Part No.	Size (in)	Part No.	Size (in)
44070	1/4 x 520	44077	1 x 260
44071	1/2 x 260	44078	1 x 520
44072	1/2 x 520	44079	1 x 1296
44073	1/2 x 1296	47271	1/2 x 260
44074	3/4 x 260	47272	1/2 x 520
44075	3/4 x 520	47274	3/4 X 260
44076	3/4 x 1296	47275	3/4 X 520

CEMENTS, PLASTIC PIPE:

LA-CO® LOC® PVC Cement, Clear

Regular Body

- For types I and II PVC pipe & fittings, schedule 40 thru 4" diameter.
- Fast set
- For use in all climates.
- Meets ASTM D-2564.
- Application temp. ranges: 35°F to 110°F.



Part No.	Size
19101	1/4 pt. ¹
19102	1/2 pt. ¹
19103	1 pt. ¹
19104	1 qt. ¹
19105	1 gal.

TEMPERATURE INDICATORS:

Thermomelt Temperature Indicator

- Accurate, fast, low-cost method for measuring surface temperatures.
- Accurate to within $\pm 1\%$ of stated temperature.
- 4-1/2" Thermomelt® Stik® features a stainless steel holder with pocket clip for convenient, easy use.
- Thermomelt® Liquid is ideal for hard to measure inaccessible and vertical surfaces such as glass, plastic, polished metal, etc.
- Thermomelt® Pellets are used in areas inaccessible to Stik® application, such as furnace interiors, where temperatures are observed at a distance.
- Meets ANSI/ASME CODE B31, & B31.3, AWS D1.1 and ASME Code Sec.I, III and VII, NIST traceable.

Type	Size
Thermomelt® Stik®	4-1/2" size - features stainless steel holder & pocket clip
Thermomelt® Liquid	2 oz. bottle
Thermomelt® Pellets	20 to a vial

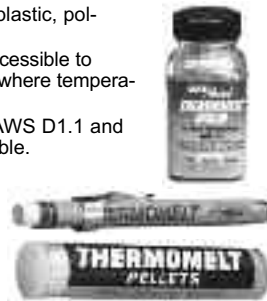

- continues -

Thermomelt Temperature Indicator (continued)

Temp. °F	Stik	Part No. Liquid	Pallets
100	86400	86406	86403
109	86409	86415	86412
113	86418	86424	86421
119	86427	86433	86430
125	86436	86442	86439
131	86445	86451	86448
138	86454	86460	86457
150	86463	86469	86466
163	86472	86478	86475
175	86481	86487	86484
182	86490	86496	86493
188	86499	86505	86502
194	86508	86514	86511
200	86517	86523	86520
206	86522	87185	86521
213	86526	86532	86529
219	86535	86541	86538
225	86544	86550	86547
238	86553	86559	86556
250	86562	86568	86565
256	86569	87184	86570
263	86571	86577	86574
269	86580	86586	86583
275	86589	86595	86592
282	86598	86604	86601
288	86607	86613	86610
294	86616	86622	86619
300	86625	86631	86628
306	86634	86640	86637
313	86643	86649	86646
319	86652	86658	86655
325	86661	86667	86664
331	86670	86676	86673
338	86679	86685	86682
344	86688	86694	86691
350	86697	86703	86700
363	86706	86712	86709
375	86715	86721	86718
388	86724	86730	86727
400	86733	86739	86736
413	86742	86748	86745
425	86751	86757	86754
438	86760	86766	86763
450	86769	86775	86772
463	86778	86784	86781

Temp. °F	Stik	Part No. Liquid	Pallets
475	86787	86793	86790
488	86796	86802	86799
500	86805	86811	86808
525	86814	86820	86817
550	86823	86829	86826
575	86832	86838	86835
600	86841	86847	86844
625	86850	86856	86853
650	86859	86865	86862
700	86868	86874	86871
750	86877	86883	86880
800	86886	86892	86889
850	86895	86901	86898
900	86904	86910	86907
950	86922	86928	86925
1000	86931	86937	86934
1022	86940	86946	86943
1050	86949	86955	86952
1100	86958	86964	86961
1150	86967	86973	86970
1200	86976	86982	86979
1250	86985	86991	86988
1300	86994	87000	86997
1350	87003	87009	87006
1400	87012	87018	87015
1425	87021	87027	87024
1450	87030	87036	87033
1480	87039	87045	87042
1500	87048	87054	87051
1550	87057	87063	87060
1600	87066	87072	87069
1650	87075	87081	87078
1700	87084	87090	87087
1750	87093	87099	87096
1800	87102	87108	87105
1850	87111	87117	87114
1900	87120	87126	87123
1950	87129	87135	87132
2000	87138	87144	87141
2050	87147	87153	87150
2100	87156	87162	87159
2150	87165	87171	87168
2200	87174	87180	87177

Note: 12 Thermomelt® Sticks® are considered a case for combination with other Markal products. Temperatures can be assorted within 1 doz. box.

Maintenance, Repair & Operations

LOCTITE

Anti-Slip Coatings

Big Foot™ epoxy flooring products provide tough, long-lasting anti-skid surfaces for added safety. Easily applied to potentially hazardous surfaces. Big Foot coatings stand up to heavy traffic and harsh environments.



Big Foot™ Low Profile Pedestrian Grade

A two-component, water-borne epoxy for recreation and bare foot traffic areas.

Big Foot™ Heavy Duty Pedestrian Grade

For areas with heavy pedestrian or light rolling traffic. Ideal for ramps, walkways, locker rooms, stairs and assembly areas.

Big Foot™ Acrylic Pedestrian Grade

A single-component elastomeric anti-slip floor and deck coating for optimum adhesion to asphalt and flexible applications.

Big Foot™ Vehicular Grade

Withstands even the heaviest rolling equipment traffic. Resists liquids as harsh as jet fuels and hydraulic fluids. Superior adhesion forms a solid bond to metal, concrete and wood.

Big Foot™ Zero V.O.C.

This 100% reactive, solvent-free epoxy has the most aggressive profile in the Big Foot line. Use in odor-sensitive areas such as wineries, food processing plants, hospitals or for confined spaces.

Big Foot™ Glow Coat

A unique glow-in-the-dark formula gives off a luminescent glow in total darkness for up to four hours after only a few seconds of exposure to artificial light. For indoor use only.

Big Foot™ Metal Primer

Two-component, epoxy-polyamide primer increases adhesion between Big Foot anti-slip coatings and metal surfaces.

Big Foot Acrylic Primer

A single-component, clear, zero V.O.C., water-based primer designed for use with Big Foot™ Acrylic Pedestrian Grade coating.

Big Foot Primer/Sealer

Specially formulated to increase adhesion and coverage of all Big Foot anti-slip coatings. For use on concrete, wood, tile and other porous substrates. Water-based.

Anti-Slip Coatings/Properties Chart

Product	Prod. No.	Container	Coverage	Color	Mixed Viscosity (cp)	Maximum Temp. (°F)	Working Time (min)	Functional Cure (hrs)
Big Foot™ Low Profile Pedestrian Grade	95631	1 gal. kit	90 ft. ²	Black	-	140	60	12
	95641	1 gal. kit		Grey				
Big Foot™ Heavy Duty Pedestrian Grade	96211	1 gal. can	50 ft. ²	Black	12,500	140	N/A	12
	96261	1 gal. can		Grey				
	96215	5 gal. pail		Black				
	96265	5 gal. pail		Grey				
Big Foot™ Acrylic Pedestrian Grade	95591	1 gal. pail	70 ft. ²	Gray	-	140	N/A	12
Big Foot™ Vehicular Grade	96221	1 gal. kit	40 ft. ²	Black	11,000	140	120	12
	96251	1 gal. kit		Grey				
	96225	5 gal. kit		Black				
	96255	5 gal. kit		Grey				
Big Foot™ Zero V.O.C.	96231	1 gal. kit	35 ft. ²	Black	10,000	140	60	24
	39915	1 gal. kit		Grey				
	96235	5 gal. kit		Black				
	96245	5 gal. kit		Grey				
Big Foot™ Glow Coat	96271	1 gal. can	70 ft. ²	Luminescent	10,000	140	N/A	4
Big Foot™ Metal Primer	96132	1 gal. kit	250 ft. ²	Clear	3,000	140	240	12
Big Foot™ Acrylic Primer	95581	1 gal. pail	250 ft. ²	Clear	-	140	N/A	1-2
Big Foot™ Primer Sealer	94142	1 gal. kit	320 ft. ²	Clear	500	140	120	3-6

- continues -

Anti-Slip Coatings (continued)

Anti-Slip Coatings/Application Selection Guide

Product	Asphalt	Wood	Concrete	Metal	Flexible Coating	Weather Resistant	Water Based	Chemical Resistant	Anti-Slip Pedestrian	Anti-Slip Vehicular	Anti-Slip Zero V.O.C.	Anti-Slip Glow in the Dark
Big Foot™ Low Profile Pedestrian Grade		X	X	X			X	O	X			
Big Foot™ Heavy Duty Pedestrian Grade		X	X	X				X	X	O		
Big Foot™ Acrylic Pedestrian Grade	X	X	X	X	X	X			X			
Big Foot™ Vehicular Grade		X	X	X				X	O	X		
Big Foot™ Zero V.O.C.		X	X	X				X	O	O	X	
Big Foot™ Glow Coat	X	X	X	X			X	O	O	O		X

X = Preferred Choice, O = Good Choice

Big Foot™ Accessories Selection Guide

Product	Prod. No.	Qty.	For Use With:
Phenolic Rollers	96121	4/case	For use with Big Foot™ Heavy Duty, Low Profile and Acrylic Pedestrian Grade, Vehicular and Zero V.O.C. Grades
Bristle Rollers	96153	2/case	For use with Big Foot™ Glow Coat, Acrylic Pedestrian Grade Primer, Metal Primer and Primer Sealer
Jiffy Mixers	96131	1/case	For use with all Big Foot™ coatings

Belt Repair

Fixmaster® belt repair products are tough urethanes designed to repair conveyor belts and other damaged rubber equipment quickly and easily. Durable, flexible repairs can be performed using formulas for temporary or lasting wear.



Fixmaster® Rapid Rubber Repair Urethane

Fast curing, abrasion-resistant urethane. Repairs will have the same durability and flexibility as the belt. The 400 ml cartridge requires the use of a Rapid Rubber Repair Gun.

Fixmaster® Flex Conveyor Belt Repair Kit

Makes lasting belt repairs. Recommended for applications where speed of application is not critical. Cures in 8-12 hours.

Fixmaster® Instant Belt Repair

Single-component, heat curing material for fast, temporary belt repairs. Requires no priming. Equipment can be operated in 30 minutes.

Fixmaster® Rapid Rubber Repair Kit

Our premium quality belt repair product, designed to repair conveyor belts and other damaged rubber equipment quickly and easily. Urethane is extremely tough, forming a repaired area that matches the belt in durability and flexibility. Returns equipment to service in as little as three hours. Requires Rapid Rubber Repair Gun.

Fixmaster® Rapid Rubber Repair Static Mixers

Use with Fixmaster Rapid Rubber Repair Gun to dispense 400 ml cartridges.

Fixmaster® Rapid Rubber Repair Gun

Use to dispense Fix master Rapid Rubber Repair 400 ml cartridges. Gun is hand-held and operates manually.

- continues -

LOCTITE

Belt Repair (continued)

Belt Repair/Properties Chart

Product	Prod. No.	Container	Coverage (in ²) @1/4" Thickness	Color	Max. Operating Temperature (°F)	Adhesive Tensile Strength (psi)	Working Time (min)	Functional Cure (hours)
Rapid Rubber Repair Urethane	96673 96671 96672	Kit 400 ml cartridge 150ml coaxial cartridge	88 33	Black	180	1,300	1	2
Flex Conveyor Belt Repair Kit	98693	1 lb. kit	94	Black	180	1,500	10	8
Instant Belt Repair	97033	1 lb.	115	Yellow	150	175	N/A	30 min.
Rapid Rubber Repair Gun	39635	Required for use with 400 ml Rapid Rubber Repair Urethane						
Rapid Rubber Repair Static Mixers	39633	Packaged 6/bag - for mixing & dispensing Rapid Rubber Repair Urethane in 400 ml cartridge						

Properties based on mixing one lb. unit at 77°F, 7 days cure

Belt Repair/Application Selection Guide

Product	Rubber Equipment	Conveyor Belt Repair: Long Term	Conveyor Belt Repair: Temporary	Heat Cure	Non-Shrinking	Oil, Grease and Water • Resistant	Lining Pumps	Forming Expansion Joints
Rapid Rubber Repair Urethane	○	×			×	×	○	○
Flex Conveyor Belt Repair		○			×	×		
Instant Belt Repair			×	×	×	×		

X = Preferred Choice, ○ = Good Choice

Cleaners

Loctite offers a complete line of highly effective general-purpose or application-specific cleaners and degreasers. Included are both aqueous and solvent-based products, all of which are free of Class I ozone-depleting compounds.

Natural Blue® Cleaner & Degreaser

Biodegradable, all-purpose, industrial strength, concentrated cleaner and degreaser. Can be economically diluted with water. Natural Blue is formulated for wipe down, pressure spraying and immersion cleaning processes – at room temperature or heated. Pine-scented, non-flammable and non-toxic. Contains no ODCs.



Fragrance-Free Natural Blue® Cleaner & Degreaser

Same product as Natural Blue but without added fragrance. It can be used in all departments of a food processing plant. Contains no ODCs.

ODC-Free Cleaner & Degreaser (Naphtha)

A non-aqueous, hydrocarbon-based solvent designed for general-purpose industrial cleaning. Safe on aluminum, rubber and most plastics, and will not cause flash rusting on water-sensitive parts. Dries residue free. Contains no ozone-depleting compounds. (Formerly referenced as 7070.)

Aqua Power™ Cleaner & Degreaser

Penetrates, dissolves and removes dirt and oil. Fast drying and residue-free. Environmentally friendly product is biodegradable, has low toxicity, no ODCs and is non-corrosive/non-caustic.

Non-Chlorinated Parts Cleaner

Penetrates, dissolves and removes dirt and oil from metal parts. Leaves no residue. Does not contain 1,1,1 trichloroethane; helps manage EPA halide limits.

Pro Strength Degreaser

Quickly dissolves and removes grease, oil and dirt from: iron, steel, aluminum, magnesium, copper, rubber, plastic and concrete. Rinses off with water.

- continues -

Cleaners (continued)

Pro Strength Parts Cleaner

Aggressively penetrates, dissolves and removes oil and grease from parts. Dries quickly with no residue. Contains no ODCs.

Pro Strength Varnish Remover

Super jet spray quickly cuts and removes grease, gum and varnish from chokes, baffle plates and carburetor linkage. Improves performance and fuel efficiency.

Battery Cleaner

Spray it on to remove corrosion from batteries. Works in just three minutes.

Battery Protector & Sealant

Stops terminal corrosion and increases battery life. Spray on battery terminals.

Cold Parts Immersion Cleaner

Removes grease, gum, varnish, paint and barrel carbon from carburetor assemblies and all metal parts. Works on all types of engines and equipment.

Electrical Contact & Parts Cleaner

Fast evaporating cleaner removes grease, oil and other contaminants from electrical parts and mechanical equipment. Contains no CFCs or HCFCs and is safe on most plastics. Non-conductive, non-corrosive.

Non-Flammable Electrical Contact Cleaner

Removes grease, oil and other contaminants from electrical parts to prevent contact failure. Dries residue-free in seconds. Nonconductive, non-corrosive, nonflammable. Contains no CFCs or Class I ODCs. Contains HCFC-141 b. May attack some sensitive plastics.

Multi-Purpose Glass Cleaner

Fast-acting professional-strength cleaner removes tough grease and dirt from glass, chrome, aluminum, stainless steel and enamel finishes. Orange-scented formula will not run or streak. Contains no ODCs.

Paint Stripper

Quickly strips and removes paint. Eliminates sanding and scraping. Works in 10-15 minutes at temperatures from -40°F to 100°F. Contains no ODCs.

Plastic Cleaner

Cleans and polishes acrylic plastic surfaces, fiberglass, formica, enamelled surfaces, ceramics, stainless steel and glass - all without scratching. Removes dirt, grease and stains. Forms a water-repellent, anti-static shield which resists fogging. Contains no ODCs.

Radiator Cleaner

This heavy duty radiator cleaner removes rust and scale from engines, radiators and water jackets. Cleans and unclogs steam cleaner coils and boiler tubes.

Chisel® Gasket Remover (Methylene Chloride)

Removes gaskets from any type of assembly in 10 to 15 minutes. Prepares metal parts for new gaskets, eliminating scraping and sanding. Works on wood; non-corrosive on aluminum. Not for use on plastics, linoleum or synthetic fibers.

Cleaners/Property Chart

Product	Prod. No.	Container
Natural Blue® Cleaner & Degreaser	82244	4 fl. oz. bottle
	82249	24 fl. oz. spray bottle
	82251	1 gal. bottle
	82253	5 gal. pail
	82254	15 gal. pail
82255	55 gal. drum	
Fragrance-Free Natural Blue® Cleaner & Degreaser	23811 20279	1 gal. bottle 55 gal. drum
Aqua Power™ Cleaner & Degreaser	30565	17 oz. net wt. aerosol
ODC-Free Cleaner & Degreaser	22355	15 oz. net wt. aerosol
	20162	16 fl. oz. pump spray
	20260	1 gal. can
Non-Chlorinated Parts Cleaner	30545	14.75 oz. net wt. aerosol
Pro Strength Degreaser	30521	15 oz. net wt. aerosol
Pro Strength Parts Cleaner	30548	19 oz. net wt. aerosol
Pro Strength Varnish Remover	30529	12 oz. net wt. aerosol
Battery Cleaner	30531	5 oz. net wt. aerosol
Battery Protector & Sealant	30532	5 oz. net wt. aerosol
Cold Parts Immersion Cleaner	30547	3.5 gal. pail
Electrical Contact & Parts Cleaner	25791	11 oz. net wt. aerosol
Multi-Purpose Glass Cleaner	30546	18.75 oz. net wt. aerosol
Non-Flammable Electrical Contact Cleaner	24379	15 oz. net wt. aerosol
Paint Stripper	81716	18 oz. net wt. aerosol
Plastic Cleaner	30559	16 fl. oz. can
Radiator Cleaner	30519	32 fl. oz. bottle
Chisel® Gasket Remover	79040	18 oz. net wt. aerosol

24 Maintenance Repair Operations

Maintenance, Repair & Operations

LOCTITE

Coatings

Loctite offers a variety of coatings to protect, seal, insulate, prevent corrosion, color code and gripping power. Many products provide excellent resistance to acids, alkalis, salt and moisture that can damage equipment.



Color Guard® Tough Rubber Coating

Inhibits rust and corrosion; seals, insulates and identifies almost any material in minutes. Creates a non-slip gripping surface. Rubber Coating won't crack or chip. Acid and alkali resistant. Lasts for years. Use to 200°F Dip, spray or brush to apply. Suggested applications include: tools, metal, electrical connections, masonry, wood, conveyors, glass, rope, fabric.

Belt Dressing & Conditioner

Extends belt life. Penetrates the cord fibers of "V" belts to restore pliability and flexibility. Prevents belt slippage due to heat, cold, dampness, and dust. Eliminates squeaking and glazing.

Extend® Rust Treatment

One-step rust treatment goes on white and converts rust to a durable, black, metal-protective coating in 10 minutes. Wirebrush parts and apply with brush or spray. Surface rust must be present. Use as a primer or finish coat. Resists temperatures to 250°F intermittent, 200°F continuous.

Rubberized Undercoating

This heavy duty undercoating seals, protects and insulates. Rubberized for maximum durability.

Maxi-Coat

Heavy duty coating provides long-term protection for metal parts, equipment and machinery. Forms a protective, waxy film which seals out moisture, air, acid and other corrosive elements. Great for protecting parts in storage. Removable.

Coatings/Properties Chart

Product	Prod. No.	Container	Color
Color Guard® Tough Rubber Coating	81812	14.5 oz. can	Black
	81808	1 gal. can	Black
	81814	14.5 fl. oz. can	Blue
	81810	1 gal. can	Blue
	81881	14.5 fl. oz. can	Clear
	81882	1 gal. can	Clear
	81811	14.5 fl. oz. can	Red
	81807	1 gal. can	Red
	81885	14.5 fl. oz. can	Safety Orange
	81886	1 gal. can	Safety Orange
	81925	14.5 fl. oz. can	White
81924	1 gal. can	White	
81813	14.5 fl. oz. can	Yellow	
81809	1 gal. can	Yellow	
Primer for Color Guard® Tough Rubber Coating	81857	1 gal. can	Gray
Thinner for Color Guard® Tough Rubber Coating	81835	1 gal. can	—

Coatings/Properties Chart

Product	Prod. No.	Container	Coating Appearance	Dry Time	Temp. Resistance (°F)
Belt Dressing & Conditioner	30527	12 oz. net wt. aerosol	White	N/A	Up to 200
Extend® Rust Treatment	30539	10.5 oz. net wt. aerosol	Converts from a white liquid to a black coating	30 min. to touch	Up to 250
	75430	1 qt. bottle			
	75448	1 gal. bottle			
75465	5 gal. pail				
Rubberized Undercoating	30538	16 oz. net wt. aerosol	Brown to black film	20 min. to touch	Up to 200
Maxi-Coat	51211	16 oz. net wt. aerosol	Yellow/off white	1-2 hours	Up to 200
	51213	1 gal. can			

Epoxies

Fixmaster® filled and general-purpose epoxies repair, rebuild and restore damaged parts to quickly return equipment to service. Cured epoxies can be drilled, tapped and machined – just like the original metal. These non-shrinking products are available in a range of performance characteristics for specific applications. Each epoxy is capable of bonding to metal, ceramic, wood, glass and some plastics.



Fixmaster® 4 Minute Epoxy

Translucent, gel-like adhesive. Sets up in 4-6 minutes. Temperature resistant up to 160°F Ideal for emergency repairs or where reduced fixturing time is desirable. Cartridge requires Fixmaster® Applicator Gun.

Fixmaster® Fast Cure Epoxy Mixer Cups

Premeasured epoxy mixer cups. Bonds in 5-15 minutes. Excellent chemical resistance. Fills porosities and can be used to build up worn parts. Ideal for bonding glass, hard plastics, rubber and metal.

Fixmaster® Fast Cure Epoxy Mixer Cups

Premeasured epoxy mixer cups. One hour working time. Fills porosities and can be used to build up worn parts. Ideal for bonding glass, hard plastics, rubber and metal.

Fixmaster® General Purpose Epoxy Mixer Cups

Premeasured epoxy mixer cups. One hour working time. Fills porosities and can be used to build up worn parts. Ideal for bonding glass, hard plastics, rubber and metal.

Fixmaster® High Performance Epoxy

Fiberglass reinforcement gives this adhesive outstanding tensile, shear strength and shock resistance up to 180°F. Recommended for forming permanent, water-resistant bonds in production and maintenance applications. Cartridge requires Fixmaster® Applicator Gun.

Fixmaster® Underwater Repair Epoxy

This putty-like material is ideal for plumbing, irrigation and marine applications because it is unaffected by chlorinated or salt water. It is hand kneadable and fully cures in 1 hour.

Fixmaster® Fast Set Steel Epoxy

Steel filled. Reaches functional cure in 10 minutes. Temperature resistant up to 200°F Recommended for repairing pipes and other equipment that must be back in service in minutes. Cartridge requires applicator gun.

Fixmaster® Applicator Gun

Sturdy hand-held manual applicator for 50 ml Fixmaster Epoxy cartridges. (Not for use with urethanes or Rapid Rubber Repair).

Fixmaster® Static Mixers

Mixing nozzles for use with Fixmaster® 50 ml epoxy cartridges. (Not for use with Rapid Rubber Repair).

Fixmaster® Aluminum Liquid

Two-part pourable epoxy system heavily reinforced with aluminum powder. For casting & repairing of aluminum parts & for making molds and fixtures.

Fixmaster® Aluminum Putty

Aluminum-filled epoxy rebuilds and repairs aluminum equipment, forming a non-rusting finish.

Fixmaster® Fast Set Steel Putty

Steel filled. Non-sagging epoxy for filling and repairing damaged metal parts quickly. Functional cure in about 10 minutes.

Fixmaster® Metal Magic Steel™

Steel epoxy in stick form. Cut off a section, knead and apply to leaking pipes or damaged equipment. Cures in 10 minutes. NSF approved, Standard 61.

Fixmaster® Stainless Steel Putty

Stainless steel filled. Forms a non-rusting, very hard, durable finish on damaged stainless steel surfaces.

– continues –

LOCTITE

Epoxies (continued)

Fixmaster® Steel Liquid

Steel filled. Pourable and self-leveling. Epoxy is recommended for casting into hard-to-reach areas, anchoring and leveling, and forming molds and fixtures.

Fixmaster® Steel Putty

Steel filled. Non-sagging, two-part epoxy that cures to a metal-like finish for rebuilding, repairing metal parts.

Fixmaster® Superior Metal

Ideal for renewing or protecting surfaces subject to corrosion, abrasion and harsh environments. Ferro-silicon filled epoxy has outstanding compressive strength, chemical resistance. Non-rusting.

Fixmaster® Wear Resistant Putty

Ceramic fibers give this trowelable putty excellent wear- and abrasion-resistance properties. Cures to smooth, low friction surface. For surfaces exposed to wear, erosion and cavitation. Non-rusting.

Fixmaster® Wet Surface Repair

Use this unique, trowelable epoxy to repair and rebuild wet, even underwater, surfaces. Bonds to wood, concrete, steel, iron, aluminum, brass and some plastics.

Epoxies/Properties Chart

Product	Prod. No.	Container	Color (cured)	Temperature Resistance, (°F)	Adhesive Tensile Shear (psi)	Working Time (min)	Fixture Time†	Full Cure
Fixmaster® 4-Minute Epoxy	97434	50 ml. cartdg. (2.0 oz.)	Trans-lucent	160	2000	3-4	10 min.	1 hr.
Fixmaster® Fast Cure Poxy Pak™ Epoxy	81120	1 oz. syringe	Clear	250	2300	1	4-6 min.	1 hr.
Fixmaster® Faster Cure Epoxy Mixer Cups	21425 21426	10-12 fl. oz. cups 10-1 oz. cups	Gray	300	2000	5	10 min.	12 hr.
Fixmaster® General Purpose Epoxy Mixer Cups	21427	10-12 fl. oz. cups	Trans-lucent	180	2000	60	1.5 hr.	24 hr.
Fixmaster® High Perform. Epoxy	99393 99394 99392	1 oz. cartdg. 50 ml cartdg. 2 gal. kit	Tan	180	3800	30	8 hr.	24 hr.
Fixmaster® Underwater Repair Epoxy	82093	4 oz. stick	White	300	700	2	5 min.	1 hr.
Fixmaster® Fast Set Steel Epoxy	96604	50 ml cartdg.	Gray	200	2600	3	5 min.	1 hr.
Fixmaster® Gun	96030	Required for use with 50 ml Fixmaster® Epoxies						
Fixmaster® Static Mixers	39634	Packaged 6/bag - for mixing & dispensing epoxies in 50 ml containers.						

Properties based on ultimate cure
Epoxy properties based on mixing 20 g. mass at 77° F.
† Time to reach handling strength.

Metal-Filled Epoxies/Properties Chart

Product	Prod. No.	Container	Coverage (in ²) @ 1/4" Thickness	Color	Max. Operating Temperature (°F)	Tensile Strength (psi)	Working Time (min)	Functional Cure (hours)
Aluminum Liquid	97453	1 lb. kit	17 in. ³	Alumin.	200	4,900	20	6
Aluminum Putty	97463	1 lb. kit	0.5	Alumin.	225	4,000	20	6
Fast Set Steel Putty	39917	1 lb. kit	0.4	Gray	200	4,600	3	10 min.
Metal Magic Steel™	98853	4 oz.	7 in. ²	Gray	250	2,500	3	10 min.
Stainless Steel Putty	97443	1 lb. kit	0.25	Gray	225	4,600	20	6
Steel Liquid	97483 97484 97482	1 lb. kit 4 lb. kit 16 lb. kit	13 in. ³ 52 in. ³ 208 in. ³	Gray	225	6,000	25	6
Steel Putty	99913 99914 99912	1 lb. kit 4 lb. kit 25 lb. kit	0.3 1.2 7.5	Gray	225	6,000	30	6
Superior Metal	97473	1 lb. kit	0.25	Dark Gray	250	5,500	20	6
Wear Resistant Putty	98742 98743	1 lb. kit 3 lb. kit	0.36 1.1	Gray	225	4,900	30	6
Wet Surface Repair Putty	96583	1 lb. kit	0.5	Gray	150	3,500	30	18

Properties are based on mixing one lb. mass at 77°F, 7 days cure.
† Ultimate cure.

Flex Urethanes

Fixmaster® urethanes are two-component repair materials that can be troweled, cast or brush-applied to rebuild or protect critical operating equipment. Tough, rubber-like properties provide protection from impact, abrasion and corrosion. Fixmaster® urethanes are non-shrinking and unaffected by oil, grease and water. Use of the recommended accessory products ensures maximum adhesion and product reliability.



Fixmaster® Flex Brushable

Two-part urethane brushes on to form abrasion and impact-resistant linings.

Fixmaster® Flex 80 Putty

Trowelable, two-part urethane for rebuilding, repairing rubber parts and linings, providing impact, abrasion and corrosion-resistant protection.

Fixmaster® Flex 80 Liquid

Castable, two-part urethane for making molds, fixtures, expansion joints and non-scratching holding fixtures.

Flex Urethanes/Properties Chart

Product	Prod. No.	Container	Coverage (in ²) @ 1/4" Thickness	Color	Max. Operating Temperature (°F)	Adhesive Tensile Strength (psi)	Working Time (min)	Functional Cure (hours)
Flex 80 Liquid	97413 97412	1 lb. kit 6 lb. kit	27 in. ³ 162 in. ³	Black	180	1,800	20	8
Flex 80 Putty	97423 97422	1 lb. kit 6 lb. kit	94 564	Black	180	1,500	10	8
Flex Brushable	97401	1 lb. kit	2160 @ 20 mis.	Black	180	2,200	10	6

Properties are based on mixing one lb. mass at 77°F, 7 days cure.

Flooring and Grout

Fixmaster® flooring products are specialty repair materials that fill or level industrial surfaces. A cost-effective, high-performance alternative to conventional flooring systems, these epoxies are non-shrinking and have good chemical and corrosion resistance and high compression strength.



Fixmaster® Deep Pour Grout

Aggregate-filled epoxy system for pours up to 6" deep, including self-leveling applications under rails and sole plates. High-strength material bonds to steel, concrete and itself. Withstands high torque loading.

Fixmaster® Fast Set Grout

Self-leveling, non-shrinking grout for installing machinery, setting anchor bolts. Cures quickly. Can be poured up to 1" thick. Compression strength and chemical resistance are superior to concrete. Forms strong bonds to old concrete and to itself.

Fixmaster® Floor Fill

Trowelable. For repairing & resurfacing cracks in concrete floors. Bonds to old and new concrete & provides greater strength & chemical resistance.

Fixmaster® High Performance Quartz

Trowelable epoxy for repairing and protecting floors exposed to concentrated acids, alkalis and solvents. Recommended for restoring and protecting old concrete.

Fixmaster® Magna-Crete

A two-component, rapid-setting concrete repair and grouting system. Chemical resistant to most common liquids and chemicals. Bonds to concrete, wood, glass, steel and other construction materials.

Fixmaster® Marine Chocking

Self-leveling, fast-curing, non-shrinking grout. Outstanding chemical and vibration resistance and compressive strength to withstand maximum loads. Approved by American Bureau of Shipping.

- continues -

24 Maintenance Repair Operations

Maintenance, Repair & Operations

LOCTITE

Flooring and Grout (continued)

Flooring & Grout/Properties Chart

Product	Prod. No.	Container	Coverage (in ²) @ 1/4" Thickness	Color	Mixed Viscosity (cp)	Maximum Temperature (°F)	Working Time (min)	Functional Cure (hours)
Deep Pour Grout	99545	5 gal. kit	660 in. ³	Black	Pourable	225	30	24
Fast Set Grout	39637	2 gal. kit	347 in. ³	Red	5,500	200	10	12
Floor Fill	99361 99365	10 lb. kit 40 lb. kit	133 in. ³ 532 in. ³	Grey	Semi-pourable	225	40	24
High Performance Quartz	96495	42 lb. kit	15 ft. ²	Gray	Paste	150	60	24
Magna-Crete	95551 95555	1 gal. kit 5 gal. kit	4.8 ft. ² 21.6 ft. ²	Gray	-	2000	15	1-2
Marine Chocking	97572 96102	2 gal. kit 2 gal. kit	370 in. ³	Green Orange	15,000	250	10	24

Gasket and Sealing

Loctite® innovative gasketing products offer precise, reliable sealing. They can be applied manually - or, for high volume assembly - can be applied by automated methods, such as tracing, stenciling and screen printing.

A leader in form-in-place gasket makers, gasket dressings and general purpose sealants, Loctite offers a choice of RTV Silicones or solvent-based products to meet broad gasketing and sealing needs.



Instant Gasket

Makes high-performance, leakproof gaskets in one minute. Equipment can be returned to service immediately. Blowout resistant and outperforms pre-cut gaskets.

Superflex™ Silicone Adhesive Sealant

General-purpose, one-part silicone adhesive sealant cures at room temperature to form a tough rubber seal. Will not slump in overhead or vertical applications. Formulated to withstand extreme temperature cycling, U.V. light & ozone. Cannot be painted. Available in aluminum, black, clear & white.

Superflex™ Blue RTV Silicone Adhesive Sealant

Cures to a tough, flexible rubber. Makes reliable "formed-in-place" gaskets that resist shrinking, cracking and migrating. Coats pre-cut gaskets to increase reliability. Temperature range -65°F to 500°F intermittent. Low volatility. Fills gaps to .25".

Superflex™ Red High Temp. Silicone Adhesive Sealant

Makes gaskets that resist temperatures to 600°F intermittent. Resists aging, weather and thermal cycling without shrinking, cracking, hardening. Fills gaps to .25".

Superflex™ Non-Corrosive RTV Silicone Clear

Neutral curing and non-corrosive. For aluminum, concrete, electrical applications. Temperature resistant to 400°F continuous service, 500°F intermittent. TT-S-00230C Type II. TT-S-001 543A, Class A.

Ultra Black® Silicone Gasket Maker

Retains high flexibility and oil resistance for longer gasket life. Temperature range -75°F to 625°F intermittent. Low odor, non-corrosive, low volatility. Resistant to most chemicals and solvents. Fills gaps to .25".

Ultra Blue® Silicone Gasket Maker

Forms tough, flexible gaskets directly on the flange. Offers excellent adhesion to oily surfaces. Low odor, non-corrosive, low volatility. Withstands temperatures to 500°F intermittent. Resistant to most chemicals and solvents. Fills gaps to .25".

Ultra Copper® High Temp. Silicone Gasket Maker

Premium silicone that can withstand operating environments to 700°F intermittent. Superior oil resistance. Low odor, non-corrosive, low volatility, non-conductive. Resistant to most chemicals and solvents. Fills gaps to .25".

Ultra Grey® Silicone Gasket Maker

Remains flexible and withstands high vibration. Designed for high-torque applications. Withstands temperatures from -75°F to 625°F Outstanding oil and shop fluid resistance. Non-corrosive, low odor.

- continues -

Gasket and Sealing (continued)

Aviation Gasket Sealant

Reliable liquid gasket sealant, dressing and coating. Thin, brushable dressing or sealer for close-fitting parts. Use to 400°F Resistant to gasoline and other solvents. Tested to MIL-S-45180 D.

Gasket Sealant #1

Reliable paste-like gasket sealant/dressing/coating. Sets quickly to a hard set and is recommended for rigid, permanent assemblies. Use to 400°F Resistant to gasoline and other solvents. Tested to MIL-S-45180 D.

Gasket Sealant #2

Reliable paste-like gasket sealant/dressing/coating. Sets more slowly to a pliable film best suited for non-rigid, vibrating assemblies. Use to 400°F Resistant to gasoline and other solvents. Tested to MIL-S-45180 D.

Hi-Tack Gasket Sealant

Red colored liquid sealant that holds gaskets in place during assembly. Seals and bonds rubber, cork, paper, felt, metal, and asbestos gaskets. Sets quickly to a very tacky film. Suitable to 500°F. Contains no ozone-depleting compounds.

High Temperature Gasket Sealant

Slow setting, non-hardening, high temperature sealant. Recommended for heavy-duty applications. Temperature range -65°F to 600°F intermittent. Resists common shop fluids.

Copper Hi-Temp Gasket Sealant Spray

Fast drying, metallic copper sealant helps dissipate heat, prevent gasket burnout and improve heat transfer. Fills hot spots and surface imperfections. Temperature range -50°F to 500°F. Resists shop fluids.

Gasket and Sealing/Properties Chart

Product	Prod. No.	Container	Color
Instant Gasket	30684	4 oz. can	Black
	30509	5 oz. cartridge	
	30507	7 oz. can	
Superflex™ RTV Silicone Adhesive Sealants	82236	300 ml cartridge	Aluminum
	59330	80 ml tube	Black
	59375	300 ml cartridge	Black
	30563	7.25 oz. can	Black
	59530	80 ml tube	Clear
	59575	300 ml cartridge	Clear
	30562	7.25 oz. can	Clear
	59430	80 ml tube	White
	59475	300 ml cartridge	White
82518	7.25 oz. can	White	
Superflex™ Blue RTV Silicone Adhesive Sealant	30560	80 ml tube	Blue
	30533	300 ml cartridge	
	30541	7.25 oz. can	
	30518	12 oz. tube	
Superflex™ Red High Temp RTV Silicone Adhesive Sealant	59630	80 ml tube	Red
	59675	300 ml cartridge	
	30564	7.25 oz. can	
82279	12 oz. tube		
Superflex™ Non-Corrosive RTV Silicone	51387	80 ml tube	Clear
	51388	300 ml cartridge	
Ultra Black® RTV Silicone Gasket Maker	59830	70 ml tube	Black
	59875	300 ml cartridge	
	59866	8.75 oz. can	
	59891	40 lb. pail	
Ultra Blue® RTV Silicone Gasket Maker	58730	70 ml tube	Blue
	58775	300 ml cartridge	
	30567	8.75 oz. can	
	58791	40 lb. pail	
Ultra Copper® RTV Silicone Gasket Maker	30542	70 ml tube	Copper
	82046	300 ml cartridge	
Ultra Grey® RTV Silicone Gasket Maker	18718	70 ml tube	Gray
	18581	300 ml cartridge	
Aviation Gasket Sealant	30517	0.25 pt. brush	Dark red-dish brown
	30516	1 pt. brush can	
Gasket Sealant #1	30510	1.5 oz. tube	Reddish brown
	30511	3 oz. tube	
	30512	11 oz. tube	
Gasket Sealant #2	30513	1.5 oz. tube	Black
	30514	3 oz. tube	
	30515	11 oz. tube	
	80964	5 gal. can	
Hi-Tack Gasket Sealant	30524	0.25 pt. brush can	Red
	30525	1 pt. brush can	
	30526	9 oz. aerosol	
High Temp. Gasket Sealant	30558	7 ft. oz. tube	Black
Copper Hi-Temp Gasket Sealant Spray	30535	9 oz. aerosol	Copper

LOCTITE

Lubricants

A variety of penetrants, greases, oils and anti-seize formulas are available for lasting, general-purpose lubrication or specific applications.

Anti-seize compounds protect mated metal parts against friction, galling and corrosion. Anti-seize also reduces wrench torque to facilitate assembly and disassembly of threaded connections.

Super Lube® synthetic-based lubricants last four times longer than traditional petroleum-based greases and work in high and low temperatures, food grade and multi-purpose applications.



C5-A® Copper Based Anti-Seize

Exclusive formula suspends copper and graphite in a high quality grease. Protects metal parts from rust, corrosion, galling and seizing at temperatures to 1800°F. Tested

Silver Grade Anti-Seize

Heavy duty, temperature-resistant, petroleum-based lubricant compound fortified with graphite and metallic flake. Inert, will not evaporate or harden in extreme cold or heat – assemblies up to 1600°F.

Nickel Anti-Seize

Copper-free. Recommended for stainless steel and other metal fittings. For preventing corrosion, seizing and galling in harsh chemical environments and temperatures to 2400°F.

Heavy Duty Anti-Seize

Metal-free. Excellent lubricity. Provides outstanding lubrication to all metals including stainless steel, aluminum, and soft metals up to 2400°F.

Moly Paste

Very low friction. Lubricates press fits, protects during break-in and under high static loads up to 750°F. Allows maximum clamping from available torque.

Food Grade Anti-Seize

Prevents seizure, galling and friction in stainless steel and other metal parts up to 900°F

Graphite-50 Anti-Seize

Electrically conductive, nonmetallic. Temperature resistant up to 900°F. Highly electrically conductive in metal-to-metal joints.

Moly-50 Anti-Seize

General-purpose thread lubricant tested to MIL-PRF-83483. Temperature resistant to 750°F. Provides excellent lubricity.

Zinc Anti-Seize

Protects aluminum and ferrous surfaces from seizure and corrosion up to 700°F Tested to AA 59313.

N-1000 High Purity Anti-Seize

Certified pure. Copper-based. Suitable for critical, long-term stainless steel applications and high nickel alloy bolting. Recommended for protecting Class 2 and 3 power plant hardware. Temperature resistant to 1800°F

N-5000 High Purity Anti-Seize

Nickel-based. Lubricates and protects Class 1, 2 and 3 power plant hardware. Recommended for highly corrosive environments to 2400°F

High Performance N-5000 High Purity Anti-Seize

Nickel-based. Maximum lubricating and anti-seize properties for Class 1, 2 and 3 power plant hardware. Temperature resistant to 2400°F

N-7000 High Purity Anti-Seize

Metal-free formulation provides high levels of purity and excellent lubricating properties. For Class 1, 2 and 3 power plant hardware. Temperature resistant to 2400°F.

– continues –

Lubricants (continued)

C-200® Solid Film Lubricant

Bake on solid film protection for engine parts, bearings and servo-mechanisms. Temperature resistant up to 750°F as a dry film lubricant, 2400°F as an anti-seize.

Dielectric Grease

Provides a moisture-proof barrier that lubricates and protects electrical equipment from salt, dirt and corrosion. High dielectric strength. Good thermal, oxidation and chemical stability.

Disc Brake Quiet

Prevents brake squeal by dampening vibration at caliper/brake pad interface. Allows a tighter fit and easier disassembly. Protects against corrosion.

Extreme Pressure Grease

Lubricates gears, bearings and slides up to 450°F. NLGI #1 rated. Withstands extremes of pressure, resists water washout. Maintains pumpability at low temperatures; will not take a hard set after cooling.

Food Grade Grease

Extreme pressure grease with temperature resistance to 450°F. NLGI #2 rated. Protects after flushouts and steam cleaning.

Gear, Chain & Cable Lubricant

Protects and prolongs the life of gears, chains, wire rope and cable. Repels dirt, sand and dust with minimum “throw-off” from centrifugal force. Contains no ozone-depleting compounds.

Hydraulic Jack Oil

Non-corrosive oil improves lubrication in all types of hydraulic units (except hydraulic brakes). Contains antioxidant, anti-rust and anti-wear additives.

Maintain™ Lubricant, Moisture Displacer & Rust Preventer

Spray-on rust preventative for all metal parts. Unfreezes rusted parts. Displaces and seals out moisture. For use on steel, aluminum, brass, copper, magnesium, and other metals and alloys. Contains no ODCs.

Moly Dry Film

Solid film lubricant for sliding surfaces and slow-moving parts. Temperature resistant up to 750°F as a dry film lubricant, 2400°F as an anti-seize. Won't squeeze out, burn off or pick up dirt.

Penetrating Oil

Penetrates, lubricates and displaces moisture. Protects against rust and corrosion. Contains no ODCs.

Silicone Lubricant

Multi-purpose aerosol stops sticking, friction, squeaking and binding of moving parts. Non-gumming. Will not mar paint, rubber or plastic surfaces. Waterproofs and electrically insulates.

Solvo-Rust® Super Penetrating Oil

Frees rusted parts and keeps them lubricated and protected from rust after use. May be applied on or near moving parts. Will not harm painted surfaces. Contains no ODCs.

White Lithium Grease

General-purpose lubricating paste for metal-to-metal and applications. Provides corrosion protection. Contains no ODCs.

Super Lube® Synthetic-Based Lubricant with PTFE Grease

Lasts 4 times longer than petroleum-based lubricants. Withstands temperatures from -45°F to 450°F (550°F intermittent). Contains PTFE for added protection against friction and wear. Non-flammable (aerosol is flammable). Contains no ODCs. NLGI #2 grease. Translucent white to slightly yellow.

Super Lube® Synthetic-Based Lightweight Oil 10 weight

Lasts 4 times longer than petroleum-based oil. Withstands temperatures from -45°F to 450°F (650°F intermittent). 10 weight oil. Non-flammable. Translucent white to slightly yellow.

Super Lube® Synthetic-Based Oil with PTFE 90-140 weight

Won't gum up or form carbon like traditional petroleum-based gear oils. Withstands temperatures from -45°F to 450°F (550°F intermittent). 90-140 weight. Non-flammable. Translucent white to slightly yellow.

– continues –

Maintenance, Repair & Operations

LOCTITE

Lubricants (continued)

Lubricants/Properties Chart

Product	Prod. No.	Container	Temp. Resistance (°F)
Heavy Duty Anti-Seize	51609	1 oz. tube	2400°F
	51605	9 oz. brush-top can	
	51606	1 lb. brush-top can	
	51607	2 lb. can	
	51608	45 lb. pail	
Moly Paste	51050	12 oz. aerosol	750°F
	51048	8 oz. brush-top can	
	51049	1 lb. can	
	51145	15 lb. can	
Food Grade Anti-Seize	51168	8 oz. brush-top can	750°F
	51170	2 lb. can	
	51171	40 lb. pail	
C5-A® Copper Based Anti-Seize	51299	2 gm pouch	1800°F
	51277	7 gm pouch	
	51001	1 oz. tube	
	51002	4 oz. tube	
	51144	4 oz. brush-top can	
	51147	8 oz. brush-top can	
	51005	10 oz. brush-top can	
	51003	12 oz. aerosol	
	51004	13 oz. cartridge	
	51006	1 lb. can	
	51007	1 lb. brush-top can	
	51008	2.5 lb. can	
	51009	8 lb. can	
	51010	25 lb. pail	
	51011	42 lb. pail	
	51146	425 lb. drum	
Nickel Anti-Seize	77124	8 oz. brush-top can	2400°F
	51286	13 oz. aerosol	
	51102	1 lb. can	
	77164	1 lb. brush-top can	
	51152	8 lb. can	
	77175	5 gal. pail	
Silver Grade Anti-Seize	80209	4 oz. brush-top can	1600°F
	76732	8 oz. brush-top can	
	76759	13 oz. aerosol	
	76764	1 lb. brush-top can	
	80206	1 gal. can	
	76775	5 gal. pail	
Graphite - 50 Anti-Seize	51084	1 lb. can	900°F
Moly-50 Anti-Seize	51094	1 lb. can	750°F
Zinc Anti-Seize	39901	1 lb. can	750°F
N-1000 Anti-Seize	51115	8 oz. brush-top can	1800°F
	51116	1 lb. can	
	51117	2 lb. can	
N-5000 Anti-Seize	51346	1 oz. tube	2400°F
	51243	8 oz. brush-top can	
	51269	1 lb. brush-top can	
	51246	2 lb. can	
	51245	8 lb. can	
High Performance N-5000 Anti-Seize	51572	1 lb brush-top can	2400°F
N-7000 Anti-Seize	51272	8 oz. brush-top can	2400°F
	51270	1 lb. brush-top can	
	51273	2 lb. brush-top can	
C-200® Solid Film Lubricant	39893	1.3 lb. can	2400°F
	39894	10 lb. can	
Dielectric Grease	30536	0.33 oz. tube	400°F
Disc Brake Quiet	30528	9 oz. aerosol	-
Extreme Pressure Grease	51242	14.5 oz. cartridge	450°F
Food Grade Grease	51252	14.5 oz. cartridge	450°F
Gear, Chain & Cable Lubricant	81251	12 oz. aerosol	
Hydraulic Jack Oil	30522	1 qt. can	120°F
	30523	1 gal. can	
Maintain™ Lubricant	81204	16 oz. aerosol	-
Moly Dry Film	39895	12 oz. aerosol	750°F
	39896	1.3 lb. can	
	39897	10 lb. can	
	39898	50 lb. pail	
Penetrating Oil	80032	1 pt. spout can	100°F
	51221	16 oz. aerosol	
Silicone Lubricant	81246	13 oz. aerosol	400°F
	51360	5.3 oz. tube	
Solve-Rust® Super Penetrating Oil	81252	13 oz. aerosol	-
White Lithium Grease	30530	1.5 oz. tube	380°F
	30543	10.75 oz. aerosol	

- continues -

Lubricants (continued)

Lubricants/Properties Chart (continued)

Product	Prod. No.	Container	Temp. Resistance (°F)
Super Lube® Grease with PTFE	82340	1 cc kit sized packet	450°F
	82324	0.5 oz. tube	
	82325	3 oz. tube	
	23755	6 oz. aerosol	
	20029	11 oz. aerosol	
	82328	14.1 oz. grease cartdg.	
	82329	400 gm can	
	82330	5 lb. pail	
	82331	30 lb. pail	
	82357	120 lb. pail	
Super Lube® Lightweight Oil	82337	1 gal. bottle	450°F
	82338	5 gal. pail	
Super Lube® Oil with PTFE	24575	32 oz. pump spray bot.	450°F
	82333	0.25 oz. precision oiler	
	82334	1 gal. bottle	
	82335	5 gal. pail	
Super Lube® Grease with PTFE	82340	1 cc kit sized packet	-45°F to 450°F continuous
	82324	0.5 oz. tube	
	82325	3 oz. tube	
	23755	6 oz. aerosol	
	20029	11 oz. aerosol	
	82328	14.1 oz. grease cartdg.	
	82329	400 gm can	
	82330	5 lb. pail	
	82331	30 lb. pail	
	82357	120 lb. pail	
Super Lube® Lightweight Oil	82337	1 gal. bottle	-45°F to 450°F continuous
	82338	5 gal. pail	
Super Lube® Oil with PTFE	24575	32 fl. oz. pump spray bot.	-65°F to 450°F continuous
	82333	0.25 oz. precision oiler	
	82334	1 gal. bottle	
	82335	5 gal. pail	

Machining Compounds

Clover® compounds have been in demand for over 80 years for cutting, smoothing and polishing metal surfaces. Clover compounds allow final finishing of metal surfaces not practical with mechanical methods alone. Available in three abrasive grain types and a choice of petroleum and water-based carriers. Common applications include: producing an ultra-flat surface such as the lapping of gauges, valve seats and mechanical seal faces; smoothing shaft surfaces and bearing races; creating perfectly-mated parts for running-in gears and finishing industrial valves, cleaning surfaces and removing material too difficult to remove by other methods, as in finishing hardened tool steel.



Clover® Silicon Carbide Grease Mix

The standard abrasive paste for fast metal removal. Produces a smooth, flat surface but not a polished one. Leaves a rust-preventing film on lapped surfaces.

Clover® Aluminum Oxide Grease Mix

For polishing and burnishing. Does not cut as fast as Silicon Carbide but tolerates higher grinding pressures. Leaves a rust-preventing film on lapped surfaces.

Clover® Clovite® Boron Carbide Grease Mix

Good diamond paste substitute. Faster cutting than silicon carbide. Good for the hardest and toughest metals such as tool steels, satellite and aerospace alloys.

Clover® Silicon Carbide Pat Gel® Water Mix

Paste for fast metal removal. Biodegradable, recommended for applications where cleanup with water is required.

Clover® Aluminum Oxide Pat Gel

For polishing and burnishing. Does not cut as fast as Silicon Carbide but tolerates higher grinding pressures. Biodegradable, recommended for applications where cleanup with water is required.

Clover® High Purity Pat Gel®

Paste for fast metal removal. Silicon carbide-filled in a biodegradable carrier. Meets purity requirements for the nuclear industry.

Clover® Duplex Packaging

Silicon Carbide Grease Mix in two convenient grit sizes (120 and 180).

- continues -

PERMATEX®/LOCTITE®

Machining Compounds (continued)

Machine Compounds/Grade and Grit Selector Guide

Grade	Grit		Average Particles Size of Abrasive Grains	
			1/1000 Inches	Microns (0.001mm)
7A	1200	Extremely Fine	0.12	3
6A	1000	Polishing, high precision lapping	0.20	5
5A	800		0.38	9
4A	600	Very Fine	0.56	14
3A	500	For fine polishing and lapping	0.68	17
2A	400		0.90	23
1A	320	Fine	1.28	33
A	280	For finishing, valve lapping, bearings, dies & gauges	1.75	44
B	240	Medium Fine	2.48	63
C	220	For cylinder lapping	2.60	66
D	180	Medium	3.40	86
NC	150	General purpose for controlled metal removal	4.80	122
E	120	Coarse	5.60	142
F	100	For the initial "cut" fast removal of metal	6.80	173
G	80		15.00	267
J	50	Very Coarse	18.00	463
K	36	For fast metal removal	28.00	710

Waterless Hand Cleaners



Formulated to remove grease, grime, paint, and adhesives, Permatex® waterless hand cleaners also contain multiple skin conditioners to help counteract the drying effects of frequent washing.

Fast Orange® Cream Hand Cleaner - Fine Pumice Formula
Thicker consistency to scoop straight from container or use with dispenser (can only). Biodegradable, waterless, and petroleum-solvent-free; cleans with fresh-scented natural citrus power. Contains aloe, lanolin, jojoba and other premium skin conditioners.

Fast Orange® Lotion Hand Cleaner - Smooth Formula
For use by those who prefer a hand cleaner without pumice or have extra-sensitive skin. Biodegradable, waterless, and petroleum solvent-free; cleans with fresh-scented natural citrus power. Contains aloe, lanolin, jojoba, and other premium skin conditioners.

Fast Orange® Cream Hand Cleaner - Smooth Formula
The fresh orange-scented alternative to traditional petroleum-based smooth cream hand cleaners. Thicker consistency to scoop straight from container or use with dispenser (can only). Biodegradable, waterless and petroleum-solvent-free; cleans with pure natural citrus power. Contains aloe, lanolin, jojoba and other premium skin conditioners.

Blue Label™ Hand Cleaner
Cream formula waterless hand cleaner. Cleans many difficult-to-remove substances. Gentle to hands, no greasy residue after use.

Fast Orange® Lotion Hand Cleaner - Fine Pumice Formula
Quickly removes ground-in grease and grime without abrading skin like coarser pumice hand cleaners. Biodegradable, waterless, and petroleum-solvent-free; cleans with fresh-scented natural citrus power. Contains aloe, lanolin, jojoba, and other premium skin conditioners.

Trounce® Cream or Lotion with Pumice
Pleasantly scented, with fine ground pumice for deep scrubbing to remove the most difficult soils. This fast-acting formula won't irritate hands or leave a greasy residue. Professional strength. Available in cream or lotion formulas.

- continues -

Waterless Hand Cleaner (Continued)

Waterless Hand Cleaners/Information

Product	Prod. No.	Container
Fast Orange® Cream Hand Cleaner (fine pumice formula)	35013 35406	14 oz. plastic tub 4.5 lb. plastic can
Fast Orange® Cream Hand Cleaner (smooth formula)	33013 33406	14 oz. plastic tub 4.5 lb. plastic can
Fast Orange® Lotion Hand Cleaner (fine pumice formula)	25108 25116 25217 25218 25104 25915	7.5 fl. oz. squeeze bottle 15 fl. oz. squeeze bottle 64 fl. oz. bottle with pump 1 gal. flat-top bottle 1 gal. bottle with pump 2 x 1 gal. bottle with pump
Fast Orange® Lotion Hand Cleaner (smooth formula)	23108 23116 23217 23218 23104 23915	7.5 fl. oz. squeeze bottle 15 fl. oz. squeeze bottle 64 fl. oz. bottle with pump 1 gal. flat-top bottle 1 gal. bottle with pump 2 x 1 gal. bottle with pump
Blue Label™ Cream Hand Cleaner	01013 01406	14 oz. can 4.5 lb. can
Trounce® Cream Hand Cleaner with Pumice	03013 03406	14 oz. can 4.5 lb. can
Trounce® Lotion Hand Cleaner with Pumice	21116 21218	15 fl. oz. squeeze bottle 128 fl. oz. bottle with pump

Wearing Compounds

Nordbak® Wearing Compounds combine the superior wear properties of ceramic and the convenience of two-part epoxies to protect equipment from corrosion, abrasion and other wear encountered in harsh industrial environments. Available in trowelable and brushable formulations with special fillers for tough conditions.



Nordbak® Wearing Compound

Large ceramic beads and fine silicon carbide in a high performance epoxy system protects against sliding abrasion to 250°F Nonsagging. Trowelable.

Nordbak® Fast Cure Wearing Compound

A faster version of Wearing Compound, this epoxy renews worn surfaces fast, reducing downtime to put equipment back in service in as little as three hours. Trowelable.

Nordbak® High Temperature Wearing Compound

Resists sliding abrasion and temperatures to 450°F Must be post-cured for maximum temperature resistance and performance. Trowelable.

Nordbak® Ultra High Temperature Wearing Compound

Resists sliding abrasion and temperatures to 550°F Must be post-cured for maximum temperature resistance and performance. Trowelable.

Nordbak® High Impact Wearing Compound

Rubber-modified epoxy protects against sliding abrasion and impact to 250°F Trowelable.

Nordbak® Castable Wearing Compound

For casting wear-resistant parts. Pourable ceramic compound can be cast into any shape. Resists temperatures to 225°F.

Nordbak® Pneu-Wear

Filled with small ceramic beads and silicon carbide for maximum protection against fine particle abrasion to 250°F Trowelable.

Nordbak® Fast Cure Pneu-Wear

Fast cure version of standard Pneu-Wear protects against fine particle abrasion to 225°F and cures in just 3 hours. Trowelable.

Nordbak® High Temperature Pneu-Wear

Protects against fine particle abrasion and temperatures to 450°F. Must be post-cured for maximum temperature resistance and performance. Trowelable.

Nordbak® Ultra High Temperature Pneu-Wear

Protects against fine particle abrasion & temperatures to 550°F. Must be post-cured for maximum temperature resistance and performance. Trowelable.

- continues -

24
Maintenance
Repair
Operations

Maintenance, Repair & Operations

LOCTITE®

Wearing Compounds (continued)

post-cured for maximum temperature resistance & performance. Trowelable.

Nordbak® Combo Bead Wearing Compound

This epoxy system combines the abrasion-resistant qualities of both large and small ceramic beads and silicon carbide. Protects against hard sliding abrasion and extends the life of material handling equipment. Trowelable.

Nordbak® Brushable Ceramic

Brushes on to form a smooth, corrosion-resistant coating. Protects against turbulence, abrasion and cavitation. Can also be used as a top coat over Nordbak wearing compounds for surface rebuilding and lasting protection. Resists temperatures to 200°F.

Nordbak® High Temperature Brushable Ceramic

Provides protection against turbulence, abrasion and cavitation up to 550°F. Must be post-cured for maximum temperature resistance and performance.

Nordbak® Chemical Resistant Coating

Smooth, glossy, low-friction finish protects against turbulence, abrasion and cavitation. This advanced epoxy protects equipment from extreme chemical attack and corrosion. Low viscosity epoxy can be applied by brush.

Nordbak® Ceramic Tile Adhesive

High strength. For securing tiles to vertical, horizontal and overhead surfaces. Excellent shock and impact resistance. Trowelable. Resists temperatures to 200°F.

Wearing Compounds/Properties Chart

Product	Prod. No.	Container	Coverage, ft ² @ 1/4" Thkns.	Color	Max. Operating Temp. (°F)	Working Time (min) 77°F	Functional Cure (hours) 77°F
Wearing Compound	99813 99812	5 lb. kit 25 lb. kit	1.75 8.75	Gray	250	30	7
Fast Cure Wearing Compound	96373	6 lb. kit	2.1	Blue	225	10	3
High Temperature Wearing Compound	99112	25 lb. kit	9	Gray	450	30	-X-
Ultra High Temperature Wearing Compound	96392	25 lb. kit	9	Gray	550	30	-X-
High Impact Wearing Compound	39918	25 lb. kit	8.75	Gray	250	30	6
Castable Wearing Compound	98992	25 lb. kit	277 in. ³	Gray	225	30	6
Pneu-Wear	98383 98382	3 lb. kit 25 lb. kit	1.1 9	Gray	250	30	6
Fast Cure Pneu-Wear	96363	6 lb. kit	2.1	Blue	225	10	3
High Temperature Pneu-Wear	98372	25 lb. kit	8.8	Gray	450	30	-X-
Ultra High Temp. Pneu-Wear	96332	25 lb. kit	8.8	Gray	550	30	-X-
Combo Bead Wearing	96303	6 lb. kit	2.3	Gray	250	25	8
Brushable Ceramic	98733 98732 96443	2 lb. kit 6 lb. kit 2 lb. kit	12* 36* 12*	Gray Gray White	200 200 200	30 30 15	6 6 5
High Temperature Brushable Ceramic	96433	2 lb. kit	21.5*	Red	600	120	-X-
Chemical Resistant Coating	96092	12 lb. kit	74*	Gray	150	20	16
Ceramic Tile Adhesive	97762	20 lb. kit	12	Beige	200	60	12

Properties based on mixing one lb. mass at 77°F, ultimate cure.
* 20 mil thickness.
-X- = Requires Heat Cure.

Special Products

These special support products provide designed, long-lasting solutions to problems.



Urethane Sealant

Single-component, gun grade caulk that bonds, seals, water-proofs up to 180°F. Outstanding adhesion properties to concrete, masonry, glass, plastics, wood, aluminum and most other metals.

Form-A-Thread® Stripped Thread Repair Kit

Permanently repairs stripped threads and fasteners in five minutes (up to SAE Grade 5 English and 8.8 metric). Allows up to 128 lb. torque and 300°F Resists most shop fluids.

2000° Putty

Single-component putty seals and repairs damaged metal in operating environments up to 2000°F. Nontoxic, water-based and solvent-free.

Prussian Blue

Aids precision fitting of machined surfaces. Locates high spots on close-to-tolerance components. Non-drying. Easy cleanup.

Pipe Repair Kit

Urethane-impregnated fiberglass tape, activated by water, for reliable temporary repairs of metal, plastic and composite pipes. Includes Metal Magic Steel™ epoxy stick and gloves. Cures in 30 minutes. Can be used to repair metal, plastic and composite pipes. NSF approved, Standard 61.

Special Products/Ordering Information

Product	Prod. No.	Container	Max. Temp. Resistance (°F)	Adhesive Appearance
2000° Putty	95724	8 oz. can	2000	Gray Paste
Form-A-Thread® Stripped Thread Repair Kit	28654	4.8 ml kit	300	Gray (mixed)
Pipe Repair Kit	96321 96322	2' x 6' tape 4' x 12' tape	250 250	Yellow Yellow
Prussian Blue	30520	0.75 oz. tube	N/A	Blue, oily Paste
Urethane Sealant	39916	10.2 oz. cartridge	180	Limestone

24
Maintenance
Repair
Operations

LOCTITE®

Gasketing - Anaerobic

Pioneered by Loctite, anaerobic gasketing technology has revolutionized the sealing of flanges in the automotive industry, in the assembly of heavy equipment and in the manufacture of various types of fluid power equipment.

Loctite® Anaerobic Gasketing materials remain liquid when exposed to air, but cure when confined between mating flanges.

Anaerobic gasketing products are best suited for small gap applications and rigid metal-to-metal assemblies.



504 Gasket Eliminator® Gap - Filling Flange Sealant

A single-component, instant low-pressure seal that fills gaps to .030".

509 Gasket Eliminator® - Flexible Flange Sealant

Product withstands minor flange movements caused by vibrations. It will not run when applied to vertical surfaces. Fluorescent blue properties allow easy visual inspection during assembly.

510 Gasket Eliminator® - High Temperature Flange Sealant

Product has a temperature range to 400°F with excellent solvent and chemical resistance. Makes or dresses gaskets in rigid assemblies. Eliminates gasket compression set.

515 Gasket Eliminator® - Flange Sealant

Makes flexible gaskets for rigid machined flanges with less than .050" gap. Flexes with flanges that move in service.

518 Gasket Eliminator® - Flange Sealant

Forms a flexible, solvent-resistant seal that will not tear or decay. Seals to 300°F and fills gaps to 0.050". Can be used on flexible metal assemblies including aluminum surfaces. Easy disassembly and cleaning.

5205 Flange Sealant

Fast curing and flexible, good sealing properties against oil and water/glycol particularly at high temperatures. High viscosity.

5206 Flange Sealant

Slow curing allows for micro-movement during assembly operations. Good sealing properties against oil and, water/glycol. High viscosity.

PROPERTIES CHART

Product	Item No.	Container	Typical Use	Color	Gap Fill	Cured State	Viscosity cP	Temp. Range (°F)	Cure Speed	Rcmd. Primer	Specific Gravity	Key Specs.
504	50441 50480	250 ml tube 300 ml cartdg.	Gap filling	Orange	Unprimed - .030" Primed - .050"	Rigid	500,000/ 1,200,000 Thixotropic	-65° to 300°	Unprimed - 4 to 24 hrs. Primed - 30 min. to 4 hrs.	NF	1.08	-
509	21525	300 ml cartdg.	Very Flexible	Blue	Unprimed - .010" Primed - .020"	Flexible	65,000/ 200,000 Thixotropic	-65° to 300°	Unprimed - 6 to 48 hrs. Primed - 1 to 6 hrs.	N	1.12	-
510	51031 51041	50 ml tube 250 ml tube	High temp. applications Excellent solvent resistance	Red	Unprimed - .010" Primed - .020"	Rigid	188,000/ 500,000 Thixotropic	-65° to 400°	Unprimed - 4 to 24 hrs. Primed - 30 min. to 4 hrs.	N	1.16	UL Classified
515	51517 51531 51580	6 ml tube 50 ml tube 300 ml cartdg.	For Flexible applications	Purple	Unprimed - .010" Primed - .050"	Flexible	275,000/ 950,000 Thixotropic	-65° to 300°	Unprimed - 1 to 12 hrs. Primed - 15 min. to 2 hrs.	N	1.10	UL Classified
518	22423 22424 51817 51831 51845	Kit Kit 6 ml tube 50 ml tube 300 ml cartdg.	For all metals including aluminum flanges	Red	Unprimed - .010" Primed - .050"	Flexible	800,000/ 3,750,000 Thixotropic	-65° to 300°	Unprimed - 4 to 24 hrs. Primed - 30 min. to 4 hrs.	N	1.13	NSF/ANSI 61 Certified Agriculture Canada Approved
573	21455 26392	50 ml tube 250 ml tube	Slow curing for extended assembly operations	Green	Unprimed - .010" Primed - .020"	Semi- rigid	19,000/ 60,000 Thixotropic	-65° to 300°	Unprimed - 6 to 48 hrs. Primed - 1 to 6 hrs.	N	1.25	-
574	24018 26338	50 ml tube 250 ml tube	Fast Curing, large gaps	Orange	Unprimed - .010" Primed - .020"	Semi- rigid	30,000/ 100,000 Thixotropic	-65° to 300°	Unprimed - 1 to 12 hrs. Primed - 15 min. to 2 hrs.	N	1.11	-
5182	18010	850 ml cartdg.	Robotic application on flanges, seals, covers	Red	Unprimed - .010" Primed - .020"	Flexible	140,000/ 580,000 Thixotropic	-65° to 300°	Unprimed - 4 to 24 hrs. Primed - 30 min. to 24 hrs.	N	1.10	-
5205	28554	50 ml bottle	Fast curing, flexible	Red	Unprimed - .010" Primed - .020"	Flexible	110,000/ 345,000 Thixotropic	-65° to 300°	Unprimed - 1 to 24 hrs. Primed - 5 min. to 24 hrs.	N or T	1.19	-
5206	28557	50 ml tube	Slow curing, flexible	Red	Unprimed - .010" Primed - .020"	Flexible	110,000/ 345,000 Thixotropic	-65° to 300°	Unprimed - 1 to 24 hrs. Primed - 5 min. to 24 hrs.	N or T	1.19	-

24
Maintenance
Repair
Operations

Maintenance, Repair & Operations

LOCTITE®

Gasketing - Silicone

Loctite® Silicone Gasketing materials include unique products with excellent fluid resistance, formulations for high operating temperatures, and UV-curing formulations for cure-in-place production requirements. Silicone gasketing products are best suited for large gap applications and stamped metal assemblies where flange flexing occurs.



Superior flexibility and adhesion accommodates joint movement. Excellent oil and transmission fluid resistance. Medium-body is easy to dispense. Non-corrosive. Low odor. Low volatility. Black.

5999 Ultra Grey™ Heavy Body - RTV Silicone Flange Sealant

High modulus for rigid flange assemblies. Heavy-body provides instant seal. Excellent oil, transmission fluid, gear oil and water/glycol resistance. Noncorrosive. Low odor. Low volatility. Grey.

FORM-IN-PLACE

5699 Ultra Grey® - RTV Silicone Flange Sealant

High modulus for rigid flange assemblies. Excellent oil, transmission fluid, gear oil, and water/glycol resistance. Medium body is easy to dispense. Non-corrosive. Low odor. Low volatility. Grey.

CURE-IN-PLACE

5950 FASTGASKET® - Flange Sealant

Designed to be robotically applied and cured in place to form a soft, reusable silicone gasket. Rapid 30 second UV cure permits in-line processing. Secondary moisture cure insures full cure even in shadowed areas. Black.

5900™ Heavy Body - RTV Silicone Flange Sealant

Superior flexibility and adhesion accommodates joint movement. Heavy-body provides instant seal. Excellent oil and transmission fluid resistance. Non-corrosive. Low odor. Low volatility. Black.

5960 FASTGASKET® - Flange Sealant

Designed to be robotically applied and cured in place to form a soft, reusable silicone gasket. Rapid 30 second UV cure permits in-line processing. Oil, transmission fluid, and water/glycol resistant. Translucent.

5910™ RTV Silicone - Flange Sealant

FORM-IN-PLACE PROPERTIES CHART

Product	Item No.	Container	Typical Use	Color	Gap Fill (in)	Extrusion Rate (gm/min)	Temp. Range (°F)	Cure Method	Cure* Speed	Specific Gravity	** Durometer	% Elongation	Tensile Strength (PSI)†
5699	18718	70 ml tube	Oil/water resistant	Gray	.240	250	-65° to 400°	Moisture	Tack free - 10 min. Full Cure - 24 hrs.	1.45	55	160	435
	18581	300 ml cartdgd.											
	18582	50 lb. pail											
	18583	550 lb. drum											
5900™	20166	300 ml cartdgd.	High adhesion, instant seal	Black	.240	35	-65° to 400°	Moisture	Tack Free - 20 min. Full Cure - 24 rs.	1.34	35	550	200
	20167	50 lb. pail											
	20168	550 lb. drum											
5910™	21746	300 ml cartdgd.	High adhesion	Black	.240	600	-65° to 400°	Moisture	Tack Free - 20 min. Full Cure - 24 hrs.	1.34	30	550	200
	21747	50 lb. pail											
	21748	550 lb. drum											
	5920	30542											
28298	300 ml cartdgd.												
21472	40 lb. pail												
5999	21744	300 ml cartdgd.	Oil/water resistant, instant seal	Gray	.240	105	-65° to 400°	Moisture	Tack Free - 10 min. Full Cure - 24 hrs.	1.45	60	175	500
	28298	50 lb. pail											
	20170	550 lb. drum											

* Varies with substrates **Shore A † Grit blasted steel

CURE-IN-PLACE SILICONES PROPERTIES CHART

Product	Item No.	Container	Color	Extrusion Rate (gm/min)	Cure Method	Cure* Speed	Hardness	% Elongation	Tensile Strength (PSI)†	Key Specs.
5950	29287	300 ml cartdgd.	Black	350	UV/ Moisture	30 seconds @ 120 mW/cm²	30	200	150	UL JMLUZ
	18495	40 lb. pail								
5960	31132	300 ml cartdgd.	Clear	350	UV	30 seconds @ 120 mW/cm²	50	200	600	-
	24707	40 lb. pail								

* Varies with substrates

24 Maintenance Repair Operations

LOCTITE®

Retaining

Loctite Corporation, the pioneer of anaerobic adhesives, has applied this technology to create retaining compounds that increase the shear strength of cylindrical, non-threaded assemblies. Finding wide acceptance as a standard method for assembling press and slip-fitted parts, Loctite® Retaining Compounds fill the "inner space" between components and cure to form a strong precision assembly. Formulated in a selection of viscosities, gap filling ability, flexibility and strength characteristics, Loctite® Retaining Compounds can be applied with automated process equipment or dispensed manually.



603 Retaining Compound - Oil Tolerant

A retaining compound tolerant of oil and other contamination. Seals and secures cylindrical assemblies up to 0.005" radial clearance. Fixtures in 10 minutes. Prevents fretting and corrosion of metal assemblies.

609 Retaining Compound - General Purpose

A low viscosity retaining compound that bonds rigid metal assemblies. Ideal for gap distances up to 0.005" diameter. Fixtures in 10 minutes and provides a shear strength of 3,000 psi after 24 hours. Easily joins dissimilar metals. Withstands temperatures to 300°F

620 Retaining Compound - High Temperature

A high temperature (450°F), high viscosity liquid retaining compound. Provides a shear strength of over 3,500 psi on steel. Locks and secures metal cylindrical assemblies up to .015" diameter clearance. Prevents metal fretting and corrosion. Seals against leakage.

635 Retaining Compound - High Strength/Slow Cure

A high viscosity, high strength retaining compound with slow cure speed to permit readjustment of parts during assembly.

638 Retaining Compound - Maximum Strength

A maximum strength retaining compound for use where high dynamic forces or cyclic loading is expected. Locks cylindrical assemblies up to .010" diameter clearance. Fixtures in 5 minutes.

640 Retaining Compound - Medium Strength/High Temperature

A medium viscosity retaining compound that resists temperatures to 400°F

641 Retaining Compound - Controlled Strength

A controlled strength retaining compound that is ideal for cylindrical parts that require disassembly. Recommended for maximum diameter clearance of 0.008". Fixtures in 10-30 minutes.

648 Retaining Compound - High Strength/Rapid Cure

A retaining compound recommended for continuous working temperatures up to 300°F. Fills gaps up to 0.006" diameter clearance. Fixtures in 5 minutes.

660 Quick Metal® Retaining Compound - Press Fit Repair

A creamy, non-running adhesive/sealant. Repairs worn machine parts. Restores correct fit to mating assemblies. Fills gaps up to 0.020" diameter clearance.

675 Retaining Compound - Medium Strength

A low viscosity retaining compound augments press fit assemblies. Slow cure speed permits readjustment of parts during assembly.

680 Retaining Compound - High Strength/High Viscosity

A retaining compound for joining fitted cylindrical parts. Fixtures in 10 minutes and provides a shear strength of 4,000 psi on steel after 24 hours. Fills diametral gap distances up to 0.015".

PROPERTIES CHART

Product	Item No.	Container	Typical Use	Color	Gap Fill (Diametral)	Viscosity cP	Shear Strength Steel/Steel (PSI)*	Temp. Range (°F)	Cure Speed	Rcmd. Primer	Specific Gravity	Key Specs.
603	21440	10 ml bottle	For close fitting parts with light contamination	Green	.005"	125	3,770	-65° to 300°	Fixture - 30 min. Full - 24 hrs.	T	1.10	-
	21441	50 ml bottle										
	21442	250 ml bottle										
609	60905	.5 ml capsule	1st generation to augment press fits	Green	.005"	125	3,000	-65° to 300°	Fixture - 10 min. Full - 24 hrs.	T	1.10	Mil-Spec (R-46082B) Type I
	60921	10 ml bottle										
	60931	50 ml bottle										
	60941	250 ml bottle										
620	62005	.5 ml capsule	For high temperature applications	Green	.015"	8,500/22,000 Thixotropic	3,800	-65° to 450°	Fixture - 1 hr. Full - 24 hrs.	N	1.16	-
	62015	10 ml bottle										
	62040	50 ml bottle										
	22241	250 ml bottle										
635	63531	50 ml bottle	1st generation high strength for slip fits	Green	.010"	2,000	4,000	-65° to 300°	Fixture - 1 hr. Full - 24 hrs.	T	1.05	Mil-Spec (R-46082B) Type III
	63541	250 ml bottle										
638	21447	10 ml bottle	High strength for loose fitted parts	Green	.010"	2,500	4,500	-65° to 300°	Fixture - 5 min. Full - 24 hrs.	T	1.09	-
	21448	50 ml bottle										
	21449	250 ml bottle										
640	64031	50 ml bottle	For high temp. applications	Green	.007"	600	3,000	-65° to 400°	Fixture - 1 hr. Full - 24 hrs.	T	1.12	Mil-Spec (R-46082B) Type II
	64041	250 ml bottle										
641	28802	10 ml bottle	Medium strength for removable bearings	Yellow	.008"	525/1,950 Thixotropic	1,700	-65° to 300°	Fixture - 30 min. Full - 24 hrs.	N	1.07	-
	21458	50 ml bottle										
	28801	250 ml bottle										
648	21443	10 ml bottle	Fast fixing for close fitting parts	Green	.006"	500	3,900	-65° to 300°	Fixture - 5 min. Full - 24 hrs.	N	1.13	-
	21444	50 ml bottle										
	21445	250 ml bottle										
660	66010	6 ml tube	For repair of worn machinery parts	Silver	.020"	250,000/1,500,000	3,335	-65° to 300°	Fixture - 10 min. Full - 24 hrs.	N	1.13	Agriculture Canada approved
	66040	50 ml tube										
	30287	250 ml tube										
661	66141	250 ml bottle	Fast anaerobic curing UV curing for edge fillets	Amber	.006"	500	3,500	-65° to 300°	Fixture - 5 min. Full - 24 hrs.	T	1.11	-
675	67541	250 ml bottle	1st generation for close fitting parts	Green	.005"	125	3,000	-65° to 300°	Fixture - 20 min. Full - 24 hrs.	T	1.09	Mil-Spec (R-46082B) Type I
680	68005	.5 ml capsule	High strength for slip fitted parts	Green	.015"	1,250	4,000	-65° to 300°	Fixture - 10 min. Full - 24 hrs.	T	1.11	NSF/ANSI 61 approved
	68015	10 ml bottle										
	68035	50 ml bottle										
	68060	250 ml bottle										

Maintenance, Repair & Operations

LOCTITE®

Surface Preparation

Loctite offers a complete line of surface preparation products to ensure the maximum performance of Loctite® Adhesives and Sealants.

Loctite® Accelerators are used to increase the cure speed and gap filling capabilities of Cyanoacrylate Adhesives. Activators are specially engineered curing agents for Structural Adhesives. Loctite® Primers are used to ensure cure on inactive surfaces and speed the cure of machinery adhesives.

All Loctite® Surface Preparation Products are available in ozone-safe (non-CFC) solvent-based and solventless formulations.

ACCELERATORS

7452 Tak Pak® Accelerator

This accelerator, with aggressive cleaning properties, promotes the cure speed of all Loctite® Cyanoacrylate Adhesives.

7113 Accelerator

This accelerator features long on-part life. Use with Loctite® Cyanoacrylate Adhesives.

ACTIVATORS

Output™ Activator

Designed for electronics applications using Loctite® Output™ Thermally Conductive Adhesives 315, 383 and 384.

7075 Activator

An acetone-based activator that promotes the proper cure of Loctite® Products 324 and 325.

7380 Activator

This solvent-free activator allows immediate mating of parts. Use with most Loctite® Acrylic Adhesives.

7387 Activator

This activator promotes cures of most Loctite® Acrylic Adhesives. This is a flammable product.

PRIMERS

7471 Primer T

A solvent-based primer speeds cure of all Loctite® Anaerobic Adhesives and ensures proper cure on inactive metals.

7649 Primer N

A solvent-based primer that features very long on-part life. Use to speed cures of all Loctite® Anaerobic Products and ensure proper cure on inactive metals. Ideal for cure conditions below room temperature.

770 PRISM® Primer

An adhesion promoter formulated for use with polyolefins and other low-energy surfaces. Use with Loctite® Cyanoacrylate Adhesives. Features fast dry time and long on-part life.

ACCELERATORS/PRIMERS PROPERTIES CHART

Product	No.	Item Container	Color	Viscosity (mPas)	Base	On-Part Life	Dry Time	Application
736	22490 73656	1 qt. can 6 oz. aerosol can	Brown	3	Trichloroethylene isopropyl alcohol	30 min.	3 min.	Anaerobics
712	20352 18636 18390	1.75 fl. oz. bottle 0.7 fl. oz. metered mist 1 gal. can	Clear/ Amber	1	Isopropanol	1 min.	<30 sec.	All cyanoacrylates
770	18396 18397	1.75 fl. oz. bottle 16 fl. oz. can	Colorless	1.25	Heptane	8 hrs.	30 sec.	All cyanoacrylates
793	18650 20246	1.75 fl. oz. bottle 16 fl. oz. bottle	Clear/ Light Amber	3	Propylene based glycol ether/water	<2 hrs.	<10 min.	All cyanoacrylates
7090	19368 12695	1 fl. oz. bottle 1 liter bottle	Light Amber	3	No solvent	1 hr.	<10 min.	Anaerobics/ cyanoacrylates
7109	22440 23034	1.75 fl. oz. bottle 1 qt. bottle	Clear/Amber	3	Perfluorocarbon	1 min.	<5 sec.	All cyanoacrylates
7113	19605 19606	1.75 fl. oz. bottle 1 gal. can	Clear	0.4	Heptane	24 hrs.	1 min.	All cyanoacrylates
7452	18490 18580 18637 18575 18576	1.75 fl. oz. brush-cap bottle 1.75 fl. oz. spray-cap bottle 0.7 fl. oz. metered mist 1 qt. can 1 gal. can	Clear/ Amber	0.4	Acetone	1 min.	<30 sec.	All cyanoacrylates
7453	20282	1.75 fl. oz. bottle	Clear/ Amber	0.4	Acetone (electronic grade)	1 min.	<30 sec.	All cyanoacrylates
7471	19267 22477 19268	1.75 fl. oz. bottle 4.5 oz. aerosol can 1 gal. can	Amber	2	Acetone/ Isopropanol	7 days	30-70 sec.	Anaerobics
7644	25727	1.75 fl. oz. aluminum bottle	Clear/ Blue-Green	1	Decafluoropentane	30 days	20-30 sec.	Anaerobics
7649	19269 21347 21348 19266	1.75 fl. oz. bottle 25 gm aerosol can 4.5 oz. aerosol can 1 gal. can	Clear/ Green	2	Acetone	30 days	30-70 sec.	Anaerobics

ACTIVATORS PROPERTIES CHART

Product	No.	Item Container	Color	Viscosity	Base	On-Part Life	Dry Time	Application
Output™ Activator	20263 21085	13 ml bottle 1 qt. can	Light Brown	1.5	Heptane/ Isopropanol	2 hrs.	None	Electronics
7075	21349 22671	1 qt. can 4.5 oz. aerosol can	Amber	2	Acetone	2 hrs.	3 min.	324, 325
7380	19822 19824 19907	1 liter can 1.75 fl. oz. bottle 1 gal. can	Light Brown	43	Monomer	2 hrs.	None	Structurals
7387	18861 18862 21088	1.75 fl. oz. bottle 1 qt. can 4.5 oz. aerosol	Light Brown	1.5	Heptane/ Isopropanol	2 hrs.	None	Structurals
25062	25062	1 liter bottle	Thin Green/ Fluorescent	1.03	Metacrylate	1 hr.	None	Anaerobics on dichromate surfaces



LOCTITE®

Threadlocking

Invented by Loctite Corporation as a revolutionary method to lock and seal threaded fasteners, Loctite® Liquid Threadlockers have found wide acceptance in a range of applications - from delicate electronic components to heavy construction equipment.

Loctite® Pre-Applied Threadlockers are dry-to-the-touch films applied to threaded fasteners by fastener suppliers and process centers located throughout North America. Ideally suited for OEMs, they improve speed of assembly and ensure quality by eliminating on-line adhesive dispensing.

Loctite® Threadlockers are available in varying viscosities and strengths for virtually any application, including exposure to extreme environments.



LIQUID THREADLOCKERS

222MS Threadlocker - Low Strength/Small Screw

Ideal for fastener diameters of 1/4" (6 mm) and smaller. Controlled lubricity for accurate clamp loads. Parts can be separated using hand tools.

242™ Threadlocker - Medium Strength

A general-purpose, removable threadlocker for fasteners between 1/4" and 3/4" (6 to 20 mm) diameters. Controlled lubricity for accurate clamp loads. Parts can be separated using hand tools.

243 Threadlocker - Oil Resistant/Medium Strength

A general-purpose medium strength threadlocker with improved oil tolerance. For fasteners between 1/4" and 3/4" (6 to 20 mm) diameters.

246 Threadlocker - High Temp./Medium Strength

This threadlocker resists oil and mild surface contamination at continuous temperatures to 450°F. Suitable for fasteners between 1/4" and 3/4" (6 to 20 mm) diameters.

262 Threadlocker - Medium* to High Strength

A permanent locking threadlocker for fasteners up to 3/4" (20 mm) diameter. High lubrication for easy assembly. Excellent for preventing rust and corrosion in extreme chemical/environmental conditions.

266 Threadlocker - High Temp./High Strength

Fast fixturing threadlocker resists oil and mild surface contamination at temperatures to 450°F. Locks fasteners up to 3/4" (20mm) in diameter.

271™ Threadlocker - High Strength

A high strength, low viscosity threadlocker for fasteners up to 1" (25 mm) diameter.

272 Threadlocker - High Temp./High Strength

Withstands temperatures to 450°F. Provides a fast cure on most surfaces including "as received" fasteners. Recommended for bolts up to 1-1/2" (36 mm) in diameter. Heat and hand tools are required for disassembly.

277 Threadlocker - High Strength

Locks fasteners up to 1-1/2" (36 mm). Protects threads from rust and corrosion. Removable with heat and hand tools.

290 Threadlocker - Wicking Grade

A medium-strength threadlocker for pre-assembled bolts up to 1/2" (12 mm). Penetrates threads by capillary action. Secures set screws and other assemblies after settings are completed. Seals welds and porous metal parts. Protects threads from rust and corrosion. Localized heating and hand tools are needed for disassembly.

294 Thread Locker - High Temp./Wicking Grade

Ideally suited for pre-assembled fasteners. Performs well on oily fasteners.

425 Assure™ Threadlocker - Surface Curing

Low strength, fast curing threadlocker for plastic fasteners. Can be applied before or after assembly.

PRE-APPLIED THREADLOCKERS

200 Dri-Loc®

A high locking strength compound that reliably secures and seals threaded fasteners.

201 Dri-Loc®

A high temperature high strength adhesive engineered to withstand application temperatures up to 400°F (204°C).

202 Dri-Loc®

A medium strength threadlocker, general purpose for many application requirements.

203 Dri-Loc®

Offers mild strength and good lubricity for easy assembly and disassembly of parts.

204 Dri-Loc®

A high strength adhesive sealant that performs consistently on plated surfaces.

205 Dri-Loc®

The lubricity of this threadlocker provides torque/tension performance that emulates uncoated fasteners. Good strength helps assure specified clamp loads.

Dri-Loc® STS

A medium strength threadlocker and straight thread sealant, formulated with excellent lubricity to minimize friction for a more controllable torque/tension relationship.

Pre-Applied Anti-Seize

Capable of withstanding temperatures to 1200°F (648°C), this pre-applied product offers instant sealing of most fluids and thread protection in corrosive environments. Reusable up to five times, Anti-Seize will perform on all part finishes and eliminate high temperature galling.

- Properties Charts On Next Page -

LOW STRENGTH

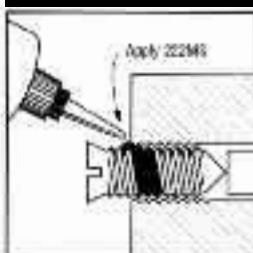

Loctite® 222MS Threadlocker

- Set screws
- Adjustment screws
- Calibration screws
- Meters and gauges

REMOVABLE

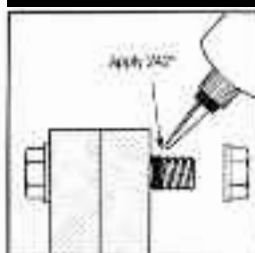

Loctite® 242® Threadlocker

- Machine tools and presses
- Pumps and compressors
- Mounting bolts
- Gear boxes

HIGH STRENGTH

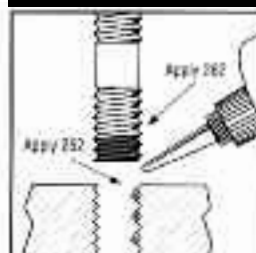

Loctite® 262 Threadlocker

- Heavy equipment
- Suspension bolts
- Motor and pump mounts
- Bearing cap bolts and studs

PENETRATING

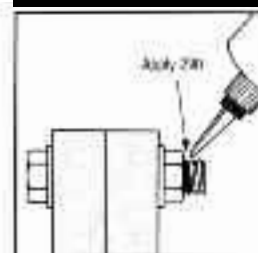

Loctite® 290 Threadlocker

- Preassembled fasteners
- Instrumentation screws
- Electrical connectors
- Carburetors

Maintenance, Repair & Operations

LOCTITE®

Threadlocking (continued)

LIQUID THREADLOCKERS PROPERTIES CHART

Product	Item No.	Container	Typical Use	Color	Viscosity cP	Torque in. lbs. (M10 Steel Nuts & Bolts) Break/Prevail	Temp. Range (°F)	Cure Speed, Steel @25°C	Oil Tolerant	Rcmd' Primer	Specific Gravity	Key Specs.
222	21463	10 ml bottle	Small screws under 1/4"	Purple	1,200/ 5,000 Thixotropic	53/30	-65° to 300°	Fixture - 20 min. Full - 24 hrs.	-	N or T	1.05	-
	21464	50 ml bottle										
	21465	250 ml bottle										
	21466	1 liter bottle										
222MS	22205	.5 ml capsule	Easy removal small screws	Purple	1,200/ 6,000 Thixotropic	62/27	-65° to 300°	Fixture - 20 min. Full - 24 hrs.	-	N or T	1.05	Mil-Spec (S-46163A) Type II, Grade M
	22221	10 ml bottle										
	22231	50 ml bottle										
	22241	250 ml bottle										
242®	24205	.5 ml capsule	Removable grade up to 3/4" bolts	Blue	1,200/ 6,000 Thixotropic	115/53	-65° to 300°	Fixture - 10 min. Full - 24 hrs.	-	N or T	1.07	Mil-Spec (S-46163A) NSF/ANSI 61 approved
	24221	10 ml bottle										
	24231	50 ml bottle										
	24241	250 ml bottle										
243	23977	.5ml capsule	Up to 3/4" bolts with light oil contamination	Blue	2,250/ 12,000 Thixotropic	180/62	-65° to 300°	Fixture - 10 min. Full - 24 hrs.	Yes	N or T	1.08	NSF/ANSI 61 approved Agriculture Canada approved
	24077	10 ml bottle										
	24078	50 ml bottle										
	24079	250 ml bottle										
246	29512	.5 ml capsule	High temp. medium strength	Blue	2,600	170/48	-65° to 450°	Fixture - 7 min. Full - 24 hrs.	Yes	N or T	1.15	-
	29513	10 ml bottle										
	29514	50 ml bottle										
	29515	250 ml bottle										
262	26205	.5 ml capsule	Permanent locking up to 3/4" bolts	Red	1,800/ 5,000 Thixotropic	190/275	-65° to 300°	Fixture - 20 min. Full - 24 hrs.	-	N or T	1.05	Mil-Spec (S-46163A) Type II, Grade O Agriculture Canada approved
	26221	10 ml tube										
	26231	50 ml bottle										
	26241	250 ml bottle										
266	26771	.5 ml capsule	High strength high temp.	Red-Orange	3,750- 9,000	270/35	-65° to 450°	Fixture - 40 min. Full - 3 hrs.	Yes	T	1.19	-
	26772	10 ml bottle										
	26773	50 ml bottle										
	26774	250 ml bottle										
271™	27105	.5 ml capsule	High strength for fasteners up to 1" diam.	Red	500	230/320	-65° to 300°	Fixture - 10 min. Full - 24 hrs.	-	N or T	1.12	Mil-Spec (S-46163A) Type I, Grade K UL classified
	27121	10 ml bottle										
	27131	50 ml bottle										
	27141	250 ml bottle										
272	27240	50 ml bottle	High temperature applications	Red	9,500	200/220/	-65° to 450°	Fixture - 30 min. Full - 24 hrs.	-	N or T	1.11	-
	27270	250 ml bottle										
	27285	1 liter bottle										
277	21434	10 ml bottle	High strength for large bolts	Red	7,000	275/275	-65° to 300°	Fixture - 30 min. Full - 24 hrs.	-	N or T	1.12	Mil-Spec (S-46163A) Type I, Grade L
	27731	50 ml bottle										
	27741	250 ml bottle										
	27743	1 liter bottle										
290	29005	.5 ml capsule	Wicking grade for preassembled parts	Green	12	85/250	-65° to 300°	Fixture - 20 min. Full - 24 hrs.	-	N or T	1.08	Mil-Spec (S-46163A) Type III, Grade R NSF/ANSI 61 certified
	29021	10 ml bottle										
	29031	50 ml bottle										
	29041	250 ml bottle										
294	27934	.5 ml capsule	High temperature wicking grade	Green	34.5	289/237	-65° to 400°	Fixture - 10 min. Full - 24 hrs.	Yes	N or T	1.13	-
	27935	10 ml bottle										
	27936	50 ml bottle										
	27937	250 ml bottle										
425	42540	20 gm bottle	For small plastic fastener	Blue	60	5/4	-65° to 180°	Fixture - 2 min. Full - 14 hrs.	-	-	1.10	-
	42561	1 lb. bottle										

PRE-APPLIED THREADLOCKERS PROPERTIES CHART

Product	Typical Use	Color	Torque in. lbs. (3/8"-16 Phosphate Steel) Break/Prevail	Temp. Range (°F)	Cure Speed, Steel @25°C	Lubricity	Key Specs.
200	General purpose	Yellow	220/105	-65° to 300°	Fixture - 10 min. Full - 72 hrs.	Medium	-
201	High temp. High Strength	Yellow	245/130	-65° to 400°	Fixture - 10 min. Full - 72 hrs.	Low	-
202	Adjustable	Green	200/105	-65° to 300°	Fixture - 10 min. Full - 72 hrs.	Medium	-
203	Medium Strength	Silver	160/75	-65° to 300°	Fixture - 10 min. Full - 72 hrs.	Medium	-
204	Plated substrates	Red	270/260	-65° to 300°	Fixture - 10 min. Full - 72 hrs.	Low	NSF/ANSI 61 certified
205	High strength on most substrates	Peach	149/57	-65° to 300°	Fixture - 10 min. Full - 72 hrs.	High	-
2015	Medium strength, high temp.	Peach	105/35	-65° to 400°	Fixture - 5 min. Full - 72 hrs.	High	-
2050	High strength	Red	300/27	65° to 300°	Fixture - 10 min. Full - 72 hrs.	High	-
STS	Medium strength, thread sealing	Light Blue	210/95	-65° to 300°	Fixture - 10 min. Full 0 24 hrs.	High	-
Anti-Seize	Thread protection, anti-seizing	Gray	-	-65° to 1,200°	Instant, reusable	Very High	-

Maintenance, Repair & Operations

LOCTITE®

Thread Sealing

Loctite® Liquid Thread Sealants seal and secure metal pipes and fittings, filling the space between threaded metal parts, and hardening to prevent leakage. Designed for low and high pressure applications, liquid thread sealants seal instantly for low pressure testing. When fully cured, they seal to the burst strength of most piping systems.

Loctite® Pre-Applied Thread Sealants are dry-to-the-touch films applied to threaded fittings by fitting suppliers and process centers located throughout North America. Pre-applied thread sealants are ideal for OEMs because they can improve speed of assembly and ensure quality by eliminating on-line dispensing of sealants.



LIQUID THREAD SEALANTS

511 Thread Sealant - Fast Curing

A low strength, rapid fixture sealant for tape red/straight fluid fittings. Controlled strength for ease of disassembly.

542 Thread Sealant - Fine Threads

A liquid sealant recommended for sealing the fine threads of hydraulic and pneumatic connectors.

545 Thread Sealant - Hydraulic/ Pneumatic Sealant

A liquid sealant for locking and sealing high pressure fluid power systems with tapered fittings. Contains no fillers and will not foul valves or fluid filtering systems.

554 Thread Sealant - Refrigerant Sealant

Excellent solvent resistance on threaded fittings and pipes up to 3" in diameter. Recommended for refrigeration systems and service with aggressive chemicals.

565 PST® Thread Sealant - Controlled Strength

A general-purpose instant sealant for tapered and straight/tapered fittings. Controlled strength for ease of disassembly.

567 PST® Thread Sealant - High Temperature

Withstands temperatures to 400°F with excellent solvent resistance. Locks and seals tapered pipe threads and fittings, including high pressure applications. Disassembles with hand tools.

572 Thread Sealant - Low Strength

Low strength sealant with moderate fixture speed for use on coarse threads.

577 Thread Sealant - Coarse Threads

Medium strength, general-purpose sealant for use on coarse, threaded components.

580 PST® Thread Sealant - Low Halogen/Low Sulfur

For threaded fittings in fossil fuel, solar and hydro plant piping systems.

592 PST® Thread Sealant - Slow Cure

Locks and seals threaded fittings. Parts may be repositioned up to 24 hours after application.

PRE-APPLIED THREAD SEALANTS

503/503HV Vibra Seal®

White, low and high viscosity, water-based pre-applied sealants.

513 Dri-Seal®

A white, low viscosity compound with good cold flow sealing properties. Prevents galling. Easy installation of aluminum parts and other soft metals, plastics, etc. NSF-61 certified for use in potable water applications.

516/517HV Vibra Seal®

Orange, low and high viscosity, water-based pre-applied sealants.

Brass Loc™ 2020

Designed for sealing and locking brass fittings against a range of fluids and gases such as motor oils, glycol solutions, and air pressure.

– Pre-Applied Thread Sealants Properties Chart on next page –

LIQUID THREAD SEALANTS PROPERTIES CHART

Product	Item No.	Container	Typical Use	Color	Viscosity cP	Temp. Range (°F)	Seal to Operating Pressure Pressure Resistance	Rcmd' Primer	Specific Gravity	Key Specs.
511	21452	50 ml tube	Low strength Rapid Fixture	Cream	19,000/ 60,000 Thixotropic	-65° to 300°	Seals operating pressures to 10,000 psi	N	1.08	–
542	21453	50 ml bottle	Fine Threads	Brown	525/1,850 Thixotropic	-65° to 300°	Seals operating pressures to 10,000 psi	N	1.06	–
545	54505 54531 54541	.5 ml capsule 50 ml bottle 250 ml bottle	Pneumatic hydraulic sealing No fillers	Purple	14,000	-65° to 300°	Seals operating pressures to 10,000 psi	N	1.20	Agriculture Canada approved
549	54941	250 ml tube	Instant seal plastic gasket	Orange	10,000/ 35,000	-65° to 300°	Seals operating pressures to 10,000 psi	N	1.25	–
554	25882 55441	10 ml tube 240 ml bottle	Refrigerant sealant High strength	Red	2,500	-65° to 300°	Seals operating pressures to 10,000 psi	N	1.02	–
564	28753 28754 28755	6 ml tube 50 ml tube 250 ml tube	General purpose	White	90,500	-65° to 300°	Seals operating pressures to 10,000 psi	N	1.17	–
566	56507 56531 56541 56571	6 ml tube 50 ml tube 250 ml tube 300 ml cartdg.	Controlled strength	White	300,000	-65° to 300°	Seals operating pressures to 10,000 psi	N	1.10	AGA 4-90 UL MH8007 (N) NSF/ANSI 61 ULC-Canada approved, Agriculture Canada approved
567	56707 56747 56765	6 ml tube 50 ml tube 250 ml tube	For stainless steel fittings	White	540,000	-65° to 400°	Seals operating pressures to 10,000 psi	M	1.14	UL MH8007 (N)
568	56841	250 ml tube	Plastic gasket	Orange	6,500	-65° to 300°	Seals operating pressures to 10,000 psi	N	1.12	–
569	56931 56941	50 ml bottle 250 ml bottle	Original hydraulic sealant	Brown	400	-65° to 300°	Seals operating pressures to 10,000 psi	N	1.05	–
571	57141	250 ml bottle	Excellent solvent resistance	Brown	20,000	-65° to 400°	Seals operating pressures to 10,000 psi	N	1.10	–
572	21454	50 ml tube	Slow cure Low strength	White	17,000/ 50,000	-65° to 300°	Seals operating pressures to 10,000 psi	N	1.25	–
577	21456 21457	50 ml tube 250 ml tube	Medium strength Coarse threads	Yellow	24,000/ 80,000 Thixotropic	-65° to 300°	Seals operating pressures to 10,000 psi	N	1.09	UL MH8007 (N)
580	58031	50 ml tube	Low halogen low sulfur thread sealant Teflon® free	White	600,000	65° to 400°	Seals operating pressures to 10,000 psi	N	1.08	–
592	59214 59231 59241	6 ml tube 50 ml tube 250 ml tube	Medium strength	White	350,000	65° to 400°	Seals operating pressures to 10,000 psi	N	1.21	UL MH8007 (N)

24
Maintenance
Repair
Operations

Maintenance, Repair & Operations

LOCTITE®

Thread Sealing (continued)

PRE-APPLIED THREAD SEALANTS PROPERTIES CHART

Product	Typical Use	Color	Temp. Range (°F)	Lubricity	Reusable	Seal to Operating Pressure
503	General purpose Low viscosity	White	-65° to 300°	High	Yes	Seals instantly
503HV	General purpose High viscosity	White	-65° to 400°	High	Yes	Seals instantly
513	Potable water (NSF/ANSI 61) High temp.	White	-65° to 350°	Medium	Yes	Seals instantly
516	General purpose High viscosity	Orange	-65° to 300°	High	Yes	Seals instantly
517	General purpose Low viscosity	Orange	-65° to 300°	High	Yes	Seals instantly
2020	Brass fittings Provides some threadlocking strength	Purple	-65° to 300°	High	Yes	Seals instantly
5061	General purpose Low lubricity for disassembled strength	Blue	65° to 300°	Low	Yes	Seals instantly



24
Maintenance
Repair
Operations

Adhesives

Whether a liquid, foam, aerosol or gel, you'll find the right product for your bonding need in the extensive family of Loctite® adhesives. These instant, acrylic, and rubber-based adhesives, provide an endless combination of cure speed, impact resistance, strength, temperature range, and solvent resistance to meet tough on-the-job requirements.



330 Depend® Adhesive

Depend® 330 sets in just minutes to a tough acrylic adhesive with high peel and impact strength. Bonds almost all combinations of materials, including glass. No-mix kit includes activator and adhesive.

380 Black Max® Instant Adhesive

For parts that encounter shock, vibration or thermal cycling, 380 is the instant adhesive choice. This black, toughened cyanoacrylate adhesive uses elastomers to withstand impact and challenging environmental conditions. Seals as well as bonds.

404 Quick Set™ Instant Adhesive

This general-purpose Quick Set™ instant adhesive liquid is the one everyone needs in their toolbox for general maintenance and repair. It sets instantly. No clamping, no mixing, no waiting. Keep it handy to bond just about anything in an instant.

454 Prism® Instant Adhesive

The ideal adhesive for porous substrates, 454 is a clear gel adhesive. As a surface insensitive cyanoacrylate, it is ideal for difficult-to-bond substrates, including rough, porous and acidic surfaces. Need to bond something on a vertical surface? The gel formulation won't run off before you put substrates together.

Black Contact Adhesive

Fast-drying, neoprene-based adhesive bonds rubber, insulation, weather-stripping, and other porous materials. Sets to a tack-free surface in 3-4 minutes. Allows repositioning of parts after initial contact. Withstands freezing temperatures.

Contact Adhesive

A professional contact adhesive that blends with black-colored moldings and weather-stripping materials. Withstands temperature extremes and is resistant to gasoline, kerosene and other solvents. Fast drying, waterproof.

All-Purpose Spray Adhesive

Bonds lightweight, porous and non-porous surfaces. Allows repositionable and permanent bonds. Fast drying; won't shrink or bleed. Resists water and humidity. Contains no ozone depleting compounds.

Max Strength Spray Adhesive

Max Strength Spray Adhesive is a high-strength product designed for bonding foam, carpet, fabrics, plastics, rubber, etc. Max Strength Spray Adhesive is resistant to extreme weather conditions, is water-resistant and sprays on clear.

PROPERTIES CHART

Product	Item No.	Container	Temp. Resistance (°F)	Adhesive Appearance	Common Surfaces Adhesive Will Bond	Bond Time*	Key Specs.
330 Depend® No-Mix Adhesive	20251	Kit - 25 ml syr. applicator 25 gm aerosol activator	-60° to 250°	Amber liquid	Glass, wood, metal, concrete, ceramic, rubber	Set-up: 1-2 min. Full Strength: 24 hrs.	NSF/ANSI 61 approved
380 Black Max® Instant Adhesive	38004 38050	3 gm net wt. tube 1 oz. net wt. bottle	-65° to 225°	Black liquid	Metal, plastic, rubber	Set-up: 90-150 sec. Full Strength: 24 hrs.	-
404 Quick Set™ Instant Adhesive	46551 46548	1/3 net wt. bottle 4 oz. net wt. bottle	-65° to 180°	Clear liquid	Metal, plastic, rubber	Set-up: 20-40 sec. Full Strength: 24 hrs.	AA-3097
454 Prism® Instant Adhesive Gel	45404 45440	3 gm net wt. tube 20 gm net wt. tube	-65° to 180°	Clear gel	Metal, plastic, rubber, cork, cardboard, leather	Set-up: 15-90 sec. Full Strength: 24 hrs.	-
Contact Adhesive	30537	5 fl. oz. tube, hangable box	180°	Thick yellow liquid	Weatherstripping, vinyl, rubber, wood, metal	Let dry 3-4 min. before assembly Sets on contact	-
Black Contact Adhesive	30540	5 fl. oz. tube	180°	Thick black liquid	Weatherstripping, vinyl, rubber, wood, metal	Let dry 3-4 min. before assembly Sets on contact	-
All-Purpose Spray Adhesive	30544	10.5 oz. net wt. aerosol	100° to 120°	Clear-drying semi-translucent foam	Lightweight porous and non-porous materials	Let dry 15-20 min. before assembly. Sets on contact.	-
Max Strength Spray Adhesive	30568	16.75 oz. net wt. aerosol	100° to 120°	Clear-drying semi-translucent foam	Foam, carpet, fabrics, plastics, rubber	Let dry 15-20 min. before assembly Sets on contact.	-

*Times are based on bonding steel to steel parts.

Loctite/LPS

SILATECH™ RTV Silicones

- Provides a tough, flexible, waterproof, oil-resistant seal
- Non-slumping
- Superior adhesion and flexibility
- Available in 300 ml cartridges
- Resealable nozzle
- Tack free in 45 minutes/fully cured in 24 hours
- Fills large cracks and seams
- Non-flammable, non-toxic



Typical Applications:

- Bonds and seals metals, wood, plastic, glass, and other substrates
- Seals ductwork, vents, flues, doors, windows, etc.
- Insulates and seals electrical wires and terminals

Item No.	color	Temp(°F)
32394	Red	up to 475°F
32389	Clear	up to 450°F
32390	Black	up to 450°F
32391	White	up to 450°F
32392	Aluminum	up to 450°F
32393	Bronze	up to 450°F

LPS

CLEANERS/DEGREASERS

NoFlash Electro Contact Cleaner

- No flash point
- Nonflammable
- No rinsing and no residue
- Quick Penetration
- Quick Evaporation
- Superior wetting action
- Safe to use on most surfaces - may be harmful to some plastics
- Contains HCFC 141b - which has 85% less ozone depletion potential than CFC 113
- Inverta Spray Valve



Meets or exceeds these specs:

McDonnell Douglas CSD #1
Boeing D6-17487 Rev. H
Learjet LAS 1239

NSN 7930-01-436-7971 (15 oz.)

Size	Part No.
15 oz.	04016

CFC Free Electro Contact Cleaner

CFC Free is a fast penetrating, fast evaporating cleaner alternative to CFCs. It does not contain CFCs, 1,1,1 or HCFCs. CFC Free dislodges oil, grease, dirt and flux from delicate electrical & electronic parts.

- Fast Evaporation
- No rinsing and no residue
- Low odor
- Nonconductive
- Safe on metal, plastic, rubber, paint, fabric and glass surfaces
- Low toxicity
- Inverta Spray Valve



NSN 6850-01-411-1834 (11 oz.)
NSN 6850-01-411-6571 (1 gal.)
NSN 6850-01-412-0044 (5 gal.)
NSN 6850-01-412-0043 (55 gal.)

Size	Part No.
11 oz.	03116
1 gal.	03101
5 gal.	03105
55 gal.	03155

Electro Contact Cleaner

ECC's new formulation does not contain any ozone depleting solvents that might affect the stratosphere.

- No ozone depletion potential
- Fast penetration
- Quick evaporation
- Penetrates into minute spaces
- Cleans/degreases delicate mechanisms
- Ideal for electrical/electronic fine parts
- Removes light greases, oils, dirt & organic soils
- No rinsing & no residue
- Superior wetting action
- Nonflammable
- Nonconductive
- Safe to use on most surfaces



Size	Part No.
14 oz.	00416
1 gal.	04128

PSC Plastic Safe Cleaner

PSC is formulated to clean oxides and other contaminant build-ups on electrical contacts. It also cleans electrical assemblies made of plastic & metal leaving no residue.

- Formulated for contact cleaning
- Contains HCFC 141b – which has 85% less ozone depletion potential than CFC 113
- No flash point
- Noncorrosive
- No rinsing & no residue
- Displaces moisture
- Very low odor
- Fast evaporation



Meets or exceeds these specs:

Learjet LAS 1239

NSN 7930-01-436-7995 (18 oz.)

Size	Part No.
18 oz.	04620

Electro 140° Contact Cleaner

- Flash point above 140° F
- Controlled evaporation
- No rinsing & no residue
- Superior wetting & penetrating action
- Precision cleaning
- Nonconductive
- Safe to use on most surfaces
- Low odor
- Inverta Spray Valve



Meets or exceeds these specs:

Boeing D6-17487 Rev.H

Learjet LAS 1239

NSN 6850-01-418-1704 (11 oz.)

NSN 6850-01-418-1706 (1 gal.)

NSN 6850-01-418-1699 (5 gal)

NSN 6850-01-418-1700 (55 gal)

Size	Part No.
11 oz.	00916
1 gal.	09128
5 gal.	00905
55 gal.	00955

QB Precision Duster

QB Precision Duster is a moisture-free compressed gas that provides a pure, quick blast for removing dirt, dust, oxide particles & other contaminants from delicate assemblies & electronic components.

- Quick blast precision duster removes contaminants, dirt, dust & other soils
- Moisture free
- No residue
- No flash point
- Nonflammable
- Nonabrasive
- Odorless



Size	Part No.
10 oz.	05710

Maintenance, Repair & Operations

LPS

PreSolve® Cleaner/Degreaser

PreSolve solves the toughest cleaning problems fast. It is especially suited for cleaning parts & equipment

- High performance cleaner propellant
- Nonflammable
- Nonconductive
- Natural-based solvent
- Does not contain 1,1,1 trichloroethane
- No rinsing & no residue
- Controlled evaporation
- Fast acting, deep penetration
- Safe on all metals & most plastics
- Inverta Spray Valve

Meets or exceeds these specs:
McDonnell Douglas CSD #1
Boeing D6-17487 Rev. H

Size	Part No.
15 oz.	01420
1 gal.	01428
5 gal.	01405
55 gal.	01455



Precision Clean Multi-Purpose Cleaner/Degreaser

Precision Clean's waterbased, biodegradable formulation is environmentally responsible.

- Water-based biodegradable formula
- Removes tough, stubborn stains & soils such as grease, oil, sludge, soot, ink, coffee & more.
- Does not contain chlorinated or petroleum solvents, bleach, ammonia, abrasives or butyl
- Contains a corrosion inhibitor to help prevent flash rusting
- Super industrial-strength
- Nonflammable
- Safe on all surfaces

Meets or exceeds these specs:
McDonnell Douglas CSD #1
Boeing D6-17487 Rev. H
AMS 1526A

Concentrate	Part No.
1 gal.	02701
5 gal.	02705
55 gal.	02755
Ready-to-Use	Part No.
55 gal.	02765
28 oz. trigger	02728



ZeroTri Cleaner/Degreaser

ZeroTri is suited for heavy-duty applications where fast drying is essential and the use of potentially carcinogenic alternative solvents is not desired.

- Heavy-duty solvent
- Fast-Acting
- Instant penetrating action
- Nonconductive
- Safe to use on most surfaces
- Ideals for cleaning metals prior to dye penetrant inspection
- Replaces 1,1,1 for removal of conformal coatings
- No rinsing & no residue
- Inverta Spray Valve

Size	Part No.
15 oz.	03520
1 gal.	03528
5 gal.	03505
55 gal.	03555



Instant Super Cleaner

- NEW Formula!
- Heavy-duty performance
- No flash point & nonflammable
- No rinsing & no residue
- Nonconductive & nonstaining
- Safe on metals
- Inverta Spray valve

Size	Part No.
20 oz.	00720



TriFree Brake Cleaner

TriFree Brake Cleaner instantly removes brake fluid, grease, oil & other contaminants on contact.

- Heavy-duty performance
- Compliant to California V.O.C. regulations
- Improves brake performance
- Helps to stop disc brake squeal
- Fast evaporation
- Nonconductive
- High solvency
- Powerful jet spray
- Does not contain 1,1,1 trichloroethane
- No rinsing & no residue

Size	Part No.
15 oz.	03620



Cable Cleaner

- Excellent for splicing & termination cleaning
- Flash point above 140°F
- Does not contain 1,1,1 trichloroethane
- Nonconductive
- Noncorrosive
- Nonstaining and leaves no residue
- Low odor
- Safe to use on most surfaces
- Superior wetting & penetration
- Can be used for metal cleaning & degreasing
- High dielectric strength of 49 kv
- Inverta Spray Valve

Size	Part No.
15 oz.	01120
1 gal.	01101



CUTTING FLUIDS

Tapmatic TriCut®

Clear plastic bottles allow end users to quickly check volume levels.

- Available in liquid or paste
- Suitable for most metals
- Extends tool life
- Reduces production costs
- Improves surface finish
- Allows increased removal rates
- Reduces friction
- Flows directly to cutting edge
- Suitable for high & low speed applications
- Provides smooth, accurate cutting action
- Is non-corrosive to steel



Size	Part No.
16 fl. oz. liquid	05316
1 gal. liquid	05328
16 oz. paste	05310
2 gal. paste	05301

Tapmatic #1 Gold

- Great for hard to machine metals
- Excellent for low speed, high pressure applications
- Minimizes torque increases
- Does not contain 1,1,1 trichloroethane, chlorinated paraffins, water, solvents or inactive fillers
- Aerosol provides a pinpoint stream with foaming action
- Safe on all metals

Meets or exceeds these specs:
Boeing BAC 5008
Boeing D6-48809

Size	Part No.
4 oz.	40304
16 fl. oz.	40320
11 oz. aerosol	40312
1 gal.	40330
5 gal.	40340
55 gal.	40360



LPS

Tapmatic AquaCut

- Water-based formula
- Excellent for high speed, low pressure applications
- Nonflammable
- Nonhazardous
- Does not contain 1,1,1 trichloroethane, sulfur, chlorine or oils
- Safe on all metals, except magnesium
- Corrosion inhibitors prevent flash rusting
- Provides fine finishes
- Cinnamon scent

Size	Part No.
4 oz.	01204
16 fl. oz.	01216
1 gal.	01228
5 gal.	01205
55 gal.	01255



Tapmatic Natural

- Nontoxic, nonhazardous & biodegradable
- Does not irritate the skin, eyes or respiratory track
- Does not contain 1,1,1 trichloroethane, sulfur, chlorine, chlorinated solvents, water, mineral oil or inactive fillers
- High performance lubricating ability eliminates galling and seizing
- Safe on all metals

Size	Part No.
4 oz.	44204
16 fl. oz.	44220
1 gal.	44230
5 gal.	44240
55 gal.	44260



Tapmatic Edge Liquid

Edge Liquid replaces flood coolants and eliminates disposal costs.

- Compatible with drop applicators
- High film strength
- Reduces friction
- Compatible with oil and water systems
- Replaces flood coolants and eliminates disposal costs
- Low toxicity
- Increases tool life
- Safe on all metals
- Excellent for high alloy metals

Size	Part No.
16 fl. oz.	43020
1 gal.	43030
5 gal.	43040
55 gal.	43060



Tapmatic Edge Lube

Edge Lube is excellent for belt, wheel and disc grinding or sawing applications.

- White, solid waxy bar
- Biodegradable
- Excellent for belt, wheel and disc grinding or sawing applications
- Eliminates heat build-up and belt loading
- Does not contain any hazardous chemicals
- Compatible with oil and water systems
- Extends grinding wheel life
- Low toxicity
- Safe on all metals

Size	Part No.
13 oz.	43200



Tapmatic Edge Creme

Edge Creme is excellent for vertical applications

- Excellent for vertical applications
- Biodegradable
- Can be applied to cutting tools before tapping or reaming
- Squeeze tube allows easy usage
- For use when drilling, tapping blind holes, forming, bending, pre-coating fasteners and lubricating rubber seals
- Does not contain any hazardous chemicals
- Ecological and economical
- Safe on all metals

Size	Part No.
11 fl. oz.	43100



Tapmatic Dual Action Plus #1

DA Plus #1 is for use on all metals except aluminum.

- Contains no ozone depleting substances
- Contains no chlorinated solvents
- Reduces friction and eliminates chip welding
- Lowers temperature through chemically controlled evaporation
- Provides ultrafine finishes an precise tolerances

Size	Part No.
16 fl. oz.	40120
1 gal.	40130
5 gal.	40140
55 gal.	40160



Tapmatic Dual Action Plus #2

DA Plus #2 is made especially for aluminum machining.

- Does not contain 1,1,1 trichloroethane
- Provides superior extreme pressure lubricity in machining aluminum and its alloys
- Reduces friction and eliminates chip welding
- Improves surface finish and extends tool life
- Made especially for aluminum

Size	Part No.
16 fl. oz.	40220
1 gal.	40230
5 gal.	40240
55 gal.	40260



LUBRICANTS/PENETRANTS

LPS 1™ Greaseless Lubricant

Contains ingredients which dissolve and remove greases and oils from delicate mechanisms. LPS 1 displaces moisture, making it ideal for drying out electrical/electronic components.

- Dries fast and resists oil, dust and dirt build-up
- Provides a dry, thin lubricating film
- Fast acting penetration
- Displaces moisture
- Loosens rusted or frozen parts
- Provides short term light corrosion resistant barrier
- Resists film build-up
- Nonflammable propellant
- Ideal for delicate mechanisms
- Safe on rubber, paint and most plastics
- Used worldwide in aviation
- Protects tools from rust
- Inverta Spray Valve

Meets or exceeds these specs:

O-W-001284a, para. 3.1-3.9
MIL-C-23411A, para. 3.1.1, 3.2-3.11
Rolls-Royce Overhaul Process 340

NSN 7930-01-380-9028 (11 oz.)
NSN 9150-01-142-9773 (5 gal.)

Size	Part No.
11 oz.	00116
1 gal.	01128
5 gal.	00105
55 gal.	00155
20 fl. oz.	00122

trigger spray



LPS 2™ Industrial Strength Lubricant

- Strong, multi-purpose lubricant and penetrant with added corrosion protection
- Provides a nondrying, light, oily film for use on indoor/outdoor equipment
- Displaces moisture
- Reduces wear caused by friction and corrosion
- Loosens rusted or frozen parts
- Provides up to one year protection
- Nonflammable propellant
- Nonconductive
- Safe on rubber, paint and most plastics
- Used worldwide in aviation
- Inverta Spray Valve

Meets or exceeds these specs:

MIL-C-16173D Grade 3 Class I, para. 3.3, 3.4, 3.7-3.11
MIL-C-81309D Type III, para. 3.4-3.5

NSN 8030-00-838-7789 (11 oz.)

Size	Part No.
11 oz.	00216
1 gal.	02128
5 gal.	00205
55 gal.	00255
20 fl. oz.	00222

trigger spray



Maintenance, Repair & Operations

LPS

White Lithium with Teflon®

- Pure white lubricant with Teflon® additives
- Provides maximum lubrication
- Rust and oxidation inhibitors protect metal
- Heat and water resistant
- Rapidly forms into a pure white grease that won't melt or wash away
- Pure white color allows easy visual inspection

Size	Part No.
10 oz.	03816



Red & Redi Multi-Purpose Red Grease

- Delivers excellent lubrication
- Prevents rust, corrosion and oxidation
- Remains effective at extremely high temperatures
- Reduces friction and vibration
- Resists shock
- Red color allows easy visual inspection
- Penetrates quickly

Size	Part No.
11 oz.	05816



LST Penetrant

End-User Education Tip – LST's "Low Surface Tension" is the measurement of a liquids ability to "bead" or form droplets. The higher the tension the more likely it is to beadup on a surface and not penetrate. LST's extremely low surface tension results in an instant spreading, consistent coating and deep penetration.

- Specially formulated with low surface tension for fast penetrating action
- Attacks rust and corrosion to free frozen parts
- Powerful foaming action provides complete surface coverage
- Displaces moisture
- Lubricates and protects metal surfaces
- Flash point of 175°F
- Inverta Spray Valve

Size	Part No.
11 oz.	01916
1 gal.	01928
5 gal.	01905
55 gal.	01955

Meets or exceeds these specs:
Federal Spec. VV-P-216C Type I
A-A-50493 Type I



BEARING GREASES

ThermaPlex FoodLube Bearing Grease

Hi-Temp remains stable and resists carbonization at high temperatures, thus reducing risk of bearing failure.

- USDA H1 category approved
- Uses only FDA listed ingredients
- Ensures safety in areas where incidental food contact may occur
- High degree of water resistance
- Excellent corrosion protection
- Very good load capacity
- Increases lubrication intervals
- Does not contain mineral oil, solvents or silicone
- Nontoxic, nonstaining & nonemulsifying

Appearance: White colored paste

Odor: Mild odor

Temperature Range: -4°F to 230°F

Dropping Point: 266°F

NLGI Grade: No. 2

4-Ball Weld Load: > 490 lbs.

Size	Part No.
14.1 oz.	70114
5 gal./35 lb.	70106
16 gal./120 lb.	70135
55 gal./400 lb.	70155



Heavy-Duty Silicone Lubricant

Ideal for surfaces like elastomers and plastics where petroleum products are unsuitable. Lubricates and protects rubber, plastic & metal parts.

- Silicone-rich formula
- Water-based formula
- Colorless & odorless
- Excellent lubricity
- Eliminates sticking, binding and squeaking
- Dry, nonstaining
- Safe on most surfaces

Size	Part No.
13 oz.	01516
5 gal.	01505
55 gal.	01555

Meets or exceeds these specs:
FDA Regulation 21 CFR 178.3570 for
Incidental Food Contact



ThermaPlex Lo-Temp Bearing Grease

- Excellent low temperature performance
- Very good load carrying capacity
- Reduces wear
- Excellent corrosion resistance
- Resists water washout
- Increases efficiency
- Decreases downtime
- Extends lubrication intervals

Appearance: Smooth, beige paste

Odor: Petroleum odor

Temperature Range: -58°F to 248°F

Dropping Point: 464°F

NLGI Grade: No. 2

4-Ball Weld Load: > 1760 lbs.

Timken "OK" Load: 60 lbs.

Size	Part No.
14.1 oz.	70314
5 gal./35 lb.	70306
16 gal./120 lb.	70335
55 gal./400 lb.	70355



Chain Mate™ Chain & Wipe Rope Lubricant

- Effective under extreme temperature and pressure ranges
- Fortified with molybdenum disulfide
- Deep penetration to the core of wire ropes
- High adhesion
- Lubricant and corrosion protectant
- Use with guards in place to eliminate costly down time
- Increases chain and wire rope life
- Reduces wear caused by friction and corrosion

Size	Part No.
11 oz.	02416



Force 842° Dry Moly Lubricant

- Works under high temperatures - 842°F and pressures - 100,000 psi
- Prevents seizure of parts
- High adhesion
- For assembly and break-in lubrication
- Excellent for cables
- Resists dust and dirt
- Water and chemical resistant
- Provides a quick drying, thin film
- Not recommended for friction bearings or light-duty bearings

Size	Part No.
11 oz.	02516



ThermaPlex Hi-Temp Bearing Grease

- Excellent high temperature performance
- Resists carbonization at high temps
- Very high dropping point
- Extends relubrication intervals
- Reduces grease consumption
- Reduces risk of bearing failure at high temps
- Very good vibration resistance
- Reduces need for multiple grease
- Ensures optimal production rates

Appearance: Smooth, brown paste

Odor: Mild odor Temperature PAW.,

Temperature Range: -40°F to 392°F

Dropping Point: 536°F

NLGI Grade: No. 2

4-Ball Weld Load: > 441 lbs.

Size	Part No.
14.1 oz.	70214
5 gal./35 lb.	70206
16 gal./120 lb.	70235
55 gal./400 lb.	70255



LPS

ThermpmaPlex Aqua Bearing Grease

- Excellent resistance to fresh/salt water
- Resists water washout
- Good adhesion properties
- Excellent corrosion resistance
- Significant load carrying capability
- Reduces wear
- Reduces grease consumption
- Greater degree of bearing protection

Appearance: Amber colored paste
Odor: Petroleum odor
Temperature Range: -4°F to 302°F
Dropping Point: 500°F-F
NLGI Grade: No. 2
Timken "OK" Load: 45 lbs.

Size	Part No.
14.1 oz.	70514
5 gal./35 lb.	70506
16 gal./120 lb.	70535
55 gal./400 lb.	70555



ThermaPlex Hi-Load Bearing Grease

Hi-Load is designed to provide long-lasting lubrication for heavily loaded bearings or those subjected to shock loading and vibration.

- Excellent load carrying ability
- Withstands shock loading
- Reduces wear from vibration
- Good corrosion resistance
- Excellent anti-wear properties
- Wide operating temperature range
- Reduces maintenance costs

Appearance: Blue/black colored paste
Odor: Petroleum odor
Temperature Range: -22°F to 302°F
Dropping Point: 446°F
NLGI Grade: No. 2
4-Ball Weld Load: > 1760 lbs.
Timken "OK" Load: 70 lbs.

Size	Part No.
14.1 oz.	70414
5 gal./35 lb.	70406
16 gal./120 lb.	70435
55 gal./400 lb.	70455



GEAR OILS

ThermaPlex Hi-Torque Gear Oils

ThermaPlex Hi-Torque Gear Oils will prevent gear failures and malfunctions caused by rust, corrosion and unwanted environmental contaminants.

- Available in a wide range of different ISO viscosity grades
- Excellent load carrying capacity
- Delivers protection against rust, corrosion and wear
- Extends drain intervals in industrial gearboxes
- Provides excellent lubrication for sliding action in spur and helical (bevel) gears
- Good thermal and oxidation stability
- Protects against foaming
- Wide temperature range
- Lowers and stabilizes gearbox running temperature

Hi-Torque Gear Oil Specs:

Appearance: Dark blue colored liquid
Specific Gravity (H₂O = 1): 0.86 to 0.89
Flash Point: > 300°F
Timken "OK" Load: 60-70 lbs.
4-Ball EP Weld Load: 250+ kg
4-Ball Load Wear Index: 50+
4-Ball Wear: < 0.35 mm
Copper Corrosion: < 1b
Rust: A/B (pass)
Oxidation Stability: 5% max

VISCOSITY FOR:

Hi-Torque 100 Gear Oil:

ISO VG: 100
SUS at 100°F: 417-510
Centistokes at 40°C: 90-110

Hi-Torque 220 Gear Oil:

ISO VG: 220
SUS at 100°F: 918-1122
Centistokes at 40°C: 198-242

Hi-Torque 320 Gear Oil:

ISO VG: 320
SUS at 100°F: 1335-1632
Centistokes at 40°C: 288-352

Hi-Torque 460 Gear Oil:

ISO VG: 460
SUS at 100°F: 1919-2346
Centistokes at 40°C: 414-506
Hi-Torque 680 Gear Oil:
ISO VG: 680
SUS at 100°F: 2837-3467
Centistokes at 40°C: 612-748

Size	Part No.	Size	Part No.
100 Gear Oil			
1 qt.	74232	5 gal.	74405
1 gal.	74201	16 gal.	74435
5 gal.	74205	55 gal.	74455
220 Gear Oil			
1 qt.	74332	1 qt.	74532
1 gal.	74301	1 gal.	74501
5 gal.	74305	5 gal.	74505
16 gal.	74335	16 gal.	74535
55 gal.	74355	55 gal.	74555
320 Gear Oil			
1 qt.	74432	1 qt.	74632
1 gal.	74401	1 gal.	74601
		5 gal.	74605
		16 gal.	74635
		55 gal.	74655



CORROSION INHIBITORS

LPS 3™ Heavy-Duty Rust Inhibitor

- Protects up to two years
- Stops rust and corrosion
- Provides non-sling lubrication
- Nonflammable propellant
- Self-healing, waxy film
- Provides anti-seize coating
- Safe to use on rubber, fabric, plastics and paints

Meets or exceeds these specs:
 Boeing BMS-3-23F Type I I
 MIL-C-0083933A, para. 3.2 - 3.16
 MIL-C-16173E Grade 2 Class I
 DMS 2150
 Airbus TN A. 007.10138 Type I Grade 2

NSN 6850-00-118-0666 (11 oz.)
NSN 6850-00-363-0841 (1 gal.)

Size	Part No.
11 oz. aerosol	00316
1 gal.	03128
5 gal.	00305
55 gal.	00355
20 fl. oz. trigger spray	00322



Procyon Corrosion Inhibitor

Designed for the aerospace industry, this durable, hard film is excellent for preventing corrosion in high risk areas such as lower cargo sections and wheel wells.

- Durable, hard transparent film
- Multi-year protection of metal
- Low odor
- Wide operating temperature range
- Resistant to saltwater, salt spray, moisture, acid, alkali fumes and other corrosive elements
- Resists dripping and puddling during spray application
- Safe to use on rubber, fabric, plastics and paints
- Ready-to-use and can be applied with conventional airless or air-operated spray equipment

Qualified to these specs:
 Boeing BMS-3-29
 Gulfstream GAC115AD

Size	Part No.
12 oz. aerosol	04216
1 gal.	04228
5 gal.	04205
55 gal.	04255



HardCoat Corrosion Inhibitor

Utilizing hard film technology, HardCoat is resistant to saltwater, salt spray, moisture, acids, alkali fumes and other corrosives.

- Durable, hard transparent film
- Multi-year protection of metal parts in outside storage
- 500+ hours salt spray resistance
- Low odor and nonconductive
- Commonly used on sides and tops of aircraft fuselages
- Resists dripping and puddling during spray application
- Safe to use on rubber, fabric, plastics and paints
- Ready-to-use and can be applied with conventional airless or air-operated spray equipment

Qualified to these specs:
 Boeing BMS-3-23F Type II

Size	Part No.
12 oz. aerosol	03316
1 gal.	03328
5 gal.	03305
55 gal.	03355



B-1007 Corrosion Inhibitor

B-1007's heavy, transparent, soft, waxy film is specially designed for Military Aviation Corrosion Prevention Programs.

- Protects up to two years
- Heavy, transparent, soft, waxy film
- Resistant to salt water, salt spray, moisture, acid, alkali fumes and other corrosive elements
- 2000+ hours salt spray resistance
- Great for mild steel stored externally
- Safe to use on rubber, fabric, plastics and paints
- Ready-to-use and can be applied with conventional airless or air-operated spray equipment

Meets or exceeds these specs:

Boeing BMS-3-26A Type II
 MIL-C-161173E Grade 4 Class I
 Airbus TN A. 007.10138 Type II Grade 2

Size	Part No.
5 gal.	03005



Maintenance, Repair & Operations

Lubrimatic Stant®

Lubrimatic Stant®

GREASE GUNS

Midget Grease Guns

Midget Grease Gun Kit

11105 - Small, Versatile gun allows for front or top pipe placement. Barrel takes 3 oz. grease cartridge or can be bulk loaded. Included push lock plunger, die cast T-handle that locks in place for loading, 5-1/2" straight grease pipe, standard-duty coupler and 3 oz. cartridge of Multi-Purpose Lithium Grease.



14 oz. Lever Grease Guns

Vari-Matic® Heavy-Duty Lever Action Grease Gun

11158 - All features of standard lever gun plus variable stroke for use in tight places. Features 3-way loading, finger grip handle on lever, air bleeder valve fitting, 5-1/2" curved grease pipe and standard coupler. Develops up to 10,000 psi, delivers 1.80 oz./40 strokes.



14 oz. Pistol Grease Guns

Pistol-Matic® Grease Gun

Pistol grip grease gun for convenient one-hand operation. Equipped with standard coupler, and capable of 3-way loading. Develops up to 7,000 psi, delivers 1 oz./40 strokes.

11143 - With 12" flex hose. Individually boxed.
11145 - With 5" straight pipe. Individually boxed.



Air Operated Grease Gun

11148 - Has an input pressure of 75 to 100 psi. Base of handle is tapped to accept 1/4" NPT male air connector. Finger operated trigger button dispenses grease without building pressure. Equipped with air bleeder valve. Develops up to 5,600 psi, delivers 1 oz./40 strokes.



PUMPS

Heavy-Duty Barrel Pump with Multidirectional Handle

11232 - Specifically designed for fast transfer of petroleum-based noncorrosive liquids from 15-55 gallon drums with 2" bung opening. Dispenses 12 oz. Per stroke. Floating piston design ensures positive seal and floating steel check valve drains liquid when not in use. Equipped with brass rings, Viton® seal, self-adjusting telescopic suction tube, non-drip spout and corrosion-resistant finish, plus rotating handle for multidirectional pumping.

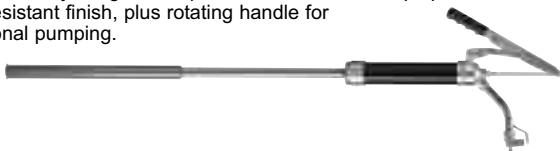

Pull Up Pump

11235 - Features die cast T-handle to dispense petroleum-based products. Floating piston design ensures positive seal and steel check valve drains liquid when not in use. Equipped with brass rings, Viton® seal, curved spout with standard male hose connector, clamping bolt for rotating pump and corrosion-resistant finish. Fits 15-55 gallon barrels with 2" bung opening. Delivers approximately 16 oz. per 12" stroke.



Rotary Pump

11240 - Has heavy-duty cast iron body for dispensing petroleum-based products. Fits 15-55 gallon drums with 2" bung opening. Discharge spout has standard threaded male hose connector. Dispenses approximately 7-1/2 gallons per 100 revolutions.



Diaphragm Fuel Transfer Pump

11243 - Fits 15-55 gallon drum with 2" bung opening. Double-action piston for higher volume transferring. Moves approximately one gallon per 9 strokes. Comes with telescoping tube assembly with neoprene seal and 8-ft. hose with spark-resistant nozzle. For point-of-use pumping and filtering of water, fuel, chemicals or petroleum products.

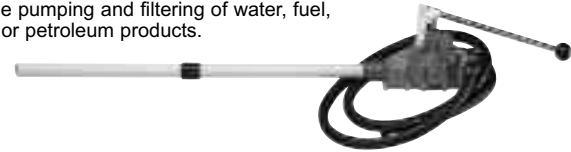

LUBRICATIONS ACCESSORIES

Hydraulic Couplers

Standard Duty Coupler

11800 - Fit any standard grease gun. Constructed so jaws automatically release when brought to sufficient angle. Can be removed from fitting without difficulty. 1/8" pipe threads can be used on rigid pipe or flexible hose. Has corrosion-resistant finish and ball check to prevent leakage and loss of pressure. All couplers (except 11805) for use with hand guns only.



11800

Heavy-Duty Coupler

11805 - Designed for use with all air-powered equipment. Heavy-duty construction withstands higher pressures. Three hardened jaws reverse for longer coupler life. 2" long coupler tapped for 1/8" pipe threads.



11805

180-degrees Swivel Coupler

11810 - Designed to lock at any angle up to 90°. Spring loaded sleeve locks coupler in place for straight applications or slides back for angular application. Has 8" overall length and corrosion-resistant finish.



11810

360-degrees Swivel Coupler

11813 - Swivels in full 360-degree circle and locks in place. 45-degree angle gives easy access to most grease fittings. Equipped with 11805 Heavy Duty Coupler.



11813

Flexible Hoses

Rubber with wire braids. For use with all hand-operated grease guns. Meets SAE 100R1: 3,000 psi working pressure/12,000 lb. burst pressure. 1/8" pipe thread on both ends.

11820 - 12" Bulk packaged.

11830 - 18" Bulk packaged.



Maintenance, Repair & Operations

Lubrimatic Stant®/Oil Dry®

Fittings & Adapters

Grease Gun Holder

11840 - Designed for wall mounting with 2 screws (not included). Center latch locks. Corrosion-resistant finish.



11840

10" Curved Grease Pipe

11841 - Extra long pipe with 1/8" pipe thread on each end. 30-degree angle.



11841

Bearing Packer

11842 - For repacking wheel and other bearings.



11842

5-1/2" Curved Grease Pipe

11850 - Standard length pipe with 1/8" pipe thread on each end. 30-degree angle.



11850

Bulk Filler Fitting

11852 - Use in grease gun heads. Zinc plated 1/8" NPT male fitting, with 0.596" O.D.



11852

Seal Off Adapter

11860 - Used for lubricating steering linkage, front suspension, universal joints, slip splines and grease plugs. 1/8" female NPT threads. For use with hand guns only.



11860

Grease Injector Needle

11865 - Designed for greasing sealed bearing applications where sharp needle-point can penetrate seal. Fitting head easily snaps into any grease gun coupler. Needle comes with protective plastic cover. For use with hand guns only.



11865

Needle Tip Adapter

11866 - For chain saws, universal joints, bicycles, etc. For use with hand guns only.



11866

Needle Adapter

11867 - For universal joints and other applications for pinpoint lubrication. 1/8" female NPT threads. For use with hand guns only.



11867

Pistol Grip Oilers

Special features include detachable, seamless metal or flexible spout; heavy-gauge metal body; black, oven-baked enamel finish; removable pump parts for easy cleaning.

- 11208** - 6 oz. Rigid Spout Pistol Oiler.
- 11210** - 6 oz. Flex Spout Pistol Oiler.
- 11215** - 16 oz. Rigid Spout Pistol Oiler.
- 11220** - 16 oz. Flex Spout Pistol Oiler.



11208

Filter Wrenches

- 11900** - Swivel Handle. Fits 3-1/2" to 3-7/8"
- 11905** - Small Car Swivel Handle. Fits 2-13/16" to 3-5/32"
- 11908** - Adjustable. Fits 2-3/4" to 4"



11900
11905

11908

Nylon Strap Oil Filter Wrench

11911 - Fits filters up to 6". Sturdy, non-slip nylon belt with 1/2" square drive.



11911

Funnel & Pans

Lubri-Spout

11920 - Fits standard quart, 5 quart and gallon bottles.



11920

Multi-Purpose Flex Funnel

11922 - 6" diameter, 15" length, 3/4" O.D. tip



11922

Rigid Super Funnel

11923 - 5" diameter, 18" length, 1/2" O.D. tip

11923

3-Piece Funnel Set

11924 - 1/2 pint, 1 pint, 2 pint



11924

6 Quart Drain Pan

11925 - 12" diameter, 4" deep



11925

Metal Funnel with Flex Support

11926 - 5-3/4" diameter, 17-1/2" length, taper tip



11926

OILS

2-Cycle Engine Oil

Formulated to improve performance, extend engine life and reduce plug fouling. Provides excellent wear protection and high temperature performance. Recommended for chain saws, trimmers, motorcycles, snow blowers, mowers and other air-cooled 2-cycle engines. Meets performance level of API-TC specifications.

- 11525** - 8 oz. Bottle.
- 11527** - Quart bottle.



11525

Oil Dry®

MRO (MAINTENANCE REPAIR & OPERATIONS)

Oil-Dri® Universal Bonded Products

Treated, chemically inert polypropylene. Universal bonded pads and rolls are extra durable to handle non-aggressive leaks and spills in high traffic areas, tool cribs and routine industrial applications. "Dimples" build strength and allow fluid to spread through the material quicker for your best absorption rate.



Item No.	Description	Dimensions W x L	Packaging	Wt (lbs)
L90902	Oil-Dri® Universal Bonded Pads	16 in. x 20 in.	100 pads/box	16
L90901	Oil-Dri® Universal Bonded Roll	30 in. x 150 ft.	1 roll/box	26
L90903	Oil-Dri® Universal Bonded Roll - Split	15 in. x 150 ft.	2 rolls/box	26

Oil-Dri® Universal 3-Step Roll

Treated, chemically inert polypropylene.

Works as three products in one – sock, pad or roll. Perforated for flexibility. Great for high-traffic areas.



Item No.	Description	Dimensions W x L	Packaging	Wt (lbs)
L90514	Oil-Dri® Universal 3-Step Roll	5 in. x 50 ft. Perforated: 16 in. x 18 in.	1 roll/bale	5

24 Maintenance Repair Operations

Maintenance, Repair & Operations

Oil-Dry® Universal Perforated Roll

Treated, chemically inert polypropylene.
Durable and perforated for added convenience.



Item No.	Description	Dimensions W x L	Packaging	Wt (lbs)
L90540	Oil-Dri® Universal Perforated Roll	30 in. x 150 ft. Perforated: 15 in. x 18 in.	1 roll/box	26

Oil-Dri® Universal Drum-Top Pads

Treated, chemically inert polypropylene.
Keeps drum tops neat. Absorbs fluids that leak from pumps and dispenser cans.



Item No.	Description	Dimensions D (in)	Packaging	Wt (lbs)
L90501	Oil-Dri® Universal Drum Top Pads	22	25 pads/bale	5

Oil-Dri® Poly-Backed Industrial Rug

Needle punched polypropylene.
Poly-backing protects floors and reduces slippage.



Item No.	Description	Dimensions W x L	Packaging	Wt (lbs)
L90691	Oil-Dri® Poly-Backed Industrial Rug	36 in. x 50 ft.	1 roll/bale	12

Oil-Dri® Industrial Rug Products

Needle punched polypropylene.
Ideal for aisles and high-traffic areas. Prevents oil tracking and provides anti-fatigue benefits for workers.



Item No.	Description	Dimensions W x L	Packaging	Wt (lbs)
L90861	Oil-Dri® Industrial Rug	36 in. x 300 ft.	1 rug/box	54
L90863	Oil-Dri® Industrial Rug - Split	18 in. x 300 ft.	2 rugs/box	54
L90864	Oil-Dri® Industrial Squares	18 in. x 18 in.	100 sq./bale	12

Oil-Dri® Textile Products

Recycled textile fabrics.
Easy to cut. Conforms to hard-to-reach spots.



Item No.	Description	Dimensions W x L	Packaging	Wt (lbs)
L90914	Oil-Dri™ Textile Blanket	40 in. x 300 ft.	1 roll/bale	58
L90915	Oil-Dri™ Textile Blanket - Split	20 in. x 300 ft.	2 rolls/bale	58
L90871	Oil-Dri™ Wood Fiber Sheets	20 in. x 20 in.	100 shts/bale	23

Oil-Dry® Accessories

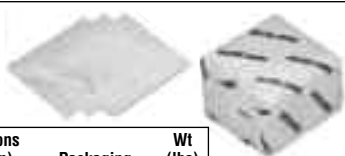

Item No.	Description	Dimensions W x L (in)	Packaging	Wt (lbs)
190950	Oil-Dri® Wipes	13 x 12.5	400 wipes/box	10
190955	Oil-Dri® Original Sock	3 x 38	8 socks/box	40

Oil Dry®

Oil-Dri™ General Sock

Polypropylene skin with recycled newspaper filler

This is Oil-Dri's most absorbent MRO sock. It can be used at the base of machines to catch nonaggressive fluid leaks and prevent spills from spreading to the floor.



Item No.	Description	Dimensions D x L (in)	Packaging	Wt (lbs)
L90890	Oil-Dri™ General Sock	3 x 48	40 socks/box	37
L90934	Oil-Dri™ General Sock	3 x 72	18 socks/box	31
L90936	Oil-Dri™ General Sock	3 x 120	10 socks/box	26

Oil-Dry Lite™ Sock

Polyester skin filled with corn cob granules.

Conforms to fit snugly around machine bases, corners and tight turns.



Item No.	Description	Dimensions D x L (in)	Packaging	Wt (lbs)
L90862	Oil-Dry Lite™ Sock	3 x 46	40 socks/box	48

Oil-Dry™ General Drip Pan/Pillows

Corrosion-resistant pan. Pillow filled with recycled newspaper

This product absorbs steady streams of nonaggressive fluids and it's cost effective too. The pan is extremely durable and can be reused. Just replace the used pillows with refills.



Item No.	Description	Dimensions L x W x H (in)	Packaging	Wt (lbs)
L90612	Oil-Dry™ General Drip Pans & Pillows	10.2 x 10.2 x 3	12 pans, 24 pillows/box	16
L90610	Oil-Dry™ Pillows (Refill Pack)	10 x 10 x 2	40 pillows/box	24

Oil-Dri™ General Pillow

Polypropylene skin with recycled newspaper filler.

Larger size pillows. Strong and thick. Great for heavy drips and spill-prone areas.



Item No.	Description	Dimensions W x L x H (in)	Packaging	Wt (lbs)
L90919	Oil-Dri™ General Pillow	16 x 21 x 2	16 pillows/box	21

Oil-Dri All Purpose Floor Absorbent

Fuller's Earth.
Superior moisture extraction process increases absorption and minimizes dust.



Item No.	Description	Packaging	Wt (lbs)
102060	Oil-Dri® Premium Floor Absorbent	50 poly bags/pallet	40 lb. bags
102070	Oil-Dri® Premium Floor Absorbent	40 poly bags/pallet	50 lb. bags
102015	Oil-Dri All-Purpose® Floor Absorbent	50 paper bags/pallet	40 lb. bags
106015	Oil-Dri All-Purpose® Floor Absorbent	40 paper bags/pallet	50 lb. bags

Maintenance, Repair & Operations

Oil Dry®

Oil-Dri® Industrial Floor Absorbent

Montmorillonite.

Absorbs and retains oil, water and grease. Great under fork lift traffic.



Item No.	Description	Packaging	Wt (lbs)
106040	Oil-Dri® Premium Industrial Floor Absorbent	50 poly bags/pallet	40 lb. bags
105090	Oil-Dri® Premium Industrial Floor Absorbent	40 poly bags/pallet	50 lb. bags
106030	Oil-Dri® Industrial Floor Absorbent	50 paper bags/pallet	40 lb. bags
105080	Oil-Dri® Industrial Floor Absorbent	40 paper bags/pallet	50 lb. bags
119041	Oil-Dri® RapidSorb Floor Absorbent	50 paper bags/pallet	40 lb. bags
119042	Oil-Dri® RapidSorb Floor Absorbent	40 paper bags/pallet	50 lb. bags

Oil-Dri® Concentrated Floor Absorbent

Fuller's Earth.

Super absorbent. These innovative granules absorb quicker with 1/3 as much product.



Item No.	Description	Packaging	Wt (lbs)
105000	Oil-Dri® Concentrated Floor Absorbent	80 pails/pallet	20 lb. pail

Additional Products

Item No.	Description	Packaging	Wt (lbs)
L90889	Oil-Dri Lite™ Floor Absorbent (Recycled Paper Pulp)	75 bags/pallet	18 lb. bags
L90830	Oil-Dri™ Cob #2 Floor Absorbent (Corn Cob Granules)	40 bags/pallet	50 lb. bags

OIL ONLY

Oil-Dry® Pads 50, 100 & 200

Melt-blown polypropylene.

Our most popular pads. Because they're hydrophobic, they float on water and are primarily used for absorbing petroleum-based fluids. Can be used on land or water.



Item No.	Description	Dimensions W x L (in)	Packaging	Wt (lbs)
Heavy Weight				
L90850	Oil-Dri® Pads 100	16 x 20	100 pads/box	18
L90853	Oil-Dri® Pads 50	30 x 40	50 pads/bale	36
Light Weight				
L90851	Oil-Dri® Pads 200	16 x 20	200 pads/box	18

Oil-Dry® Rolls

Melt-blown polypropylene.

Great for over sprays next to leaky equipment. Easily cuts to any configuration.



Item No.	Description	Dimensions W x L	Packaging	Wt. (lbs)
Heavy Weight				
L90780	Oil-Dri® Roll 30	30 in. x 150 ft.	1 roll/box	30
L90783	Oil-Dri® Roll 15D	15 in. x 150 ft.	2 rolls/box	30

Oil-Dri® Smart Rolls & Pads

Melt-blown polypropylene.

The smart buy when you're on a tight budget. Ideal in low-traffic area, underneath hoses and next to leaky equipment. Highly absorbent.



Item No.	Description	Dimensions W x L	Packaging	Wt (lbs)
Middle Weight				
L90781	Oil-Dri® Smart Roll 30	30 in. x 150 ft.	1 roll/box	22
L90782	Oil-Dri® Smart Roll 15D	15 in. x 150 ft.	2 roll/box	22
L90904	Oil-Dri® Smart Pads	16 in. x 20 in.	100 pads/box	13

Oil-Dri® Bonded Products

Melt-blown polypropylene.

For high-traffic areas, these are your products. They are dimpled to maintain product strength and maximum absorbency. Will not shed, so they work well on water too. Neat and easy to clean up.



Item No.	Description	Dimensions W x L	Packaging	Wt (lbs)
L90812	Oil-Dri® Bonded Pads	16 in. x 20 in.	100 pads/box	18
L90814	Oil-Dri® Bonded Roll	30 in. x 150 ft.	1 roll/box	30
L90664	Oil-Dri® Bonded Roll - Split	15 in. x 150 ft.	2 rolls/box	30

Oil-Dri® Oil Only 3-Step Roll

Melt-blown polypropylene.

Works as three products in one - sock, pad or roll. Perforations make it flexible.



Item No.	Description	Dimensions W x L	Packaging	Wt (lbs)
L90503	Oil-Dri® Oil Only 3 Step Roll	5 in. x 50 ft. Perforated: 16 in. x 18 in.	1 roll/bale	5

Oil-Dri® Oil Only Drum-Top Pads

Melt-blown Polypropylene.

Keeps drum tops neat. Absorbs fluid leaks from pumps and dispenser cans.



Item No.	Description	Dimensions D (in)	Packaging	Wt (lbs)
L90910	Oil-Dri® Oil Only Drum Top Pad	22 in.	25 pads/bale	5

Oil-Dri® Iron Man Pads

Melt-blown polypropylene.

The strongest pad. Will not tear or shed and is reusable after wringer or centrifuge extraction.



Item No.	Description	Dimensions W x L	Packaging	Wt (lbs)
L90818	Oil-Dri® Iron Man Pads	17 in. x 18 in.	100 pads/box	13

Oil-Dri® Boom

Melt-blown polypropylene.

For emergency spills on water, this is the product. It absorbs petroleum-based fluids and contains spills for easier handling. Booms have links at both ends which hook together for any size spill.



Item No.	Description	Dimensions D x L	Packaging	Wt (lbs)
L90855	Oil-Dri® Boom 810	8 in. x 10 ft.	4 booms/bale	48
L90857	Oil-Dri® Boom 510	5 in. x 10 ft.	4 booms/bale	25

Maintenance, Repair & Operations

Oil Dry®

Oil-Dri® Poly Sock

Melt-blown polypropylene.
This sock is very versatile. It handles petroleum-based fluids in routine industrial applications and tight, hard-to-reach areas.



Item No.	Description	Dimensions D x L	Packaging	Wt (lbs)
L90898	Oil-Dri® Poly Sock	3 in. x 48 in.	12 socks/box	13

Oil-Dri® Bilge Sock

Melt-down polypropylene.
Skims oil off water in confined spaces. Designed to work in tight area, machine sumps and drains.



Item No.	Description	Dimensions D x L	Packaging	Wt (lbs)
L90909	Oil-Dri® Bilge Sock	3 in. x 18 in.	20 socks/box	16

Oil-Dri® Pillow 10P

Melt-blown polypropylene.
Ideal in bilge areas of ships. Clip attached for easy use and removal.



Item No.	Description	Dimensions D x L	Packaging	Wt (lbs)
L90858	Oil-Dri® Pillow 10P	8 in. x 18 in.	10 pillows/bale	18

Oil-Dri® Sweep

Melt-blown polypropylene.
Great for thin slicks and surface spills on water. Features large absorbent surface area and easy-to-attach ends. Provides mobility for small craft towing and deployment.



Item No.	Description	Dimensions W x L	Packaging	Wt (lbs)
L90859	Oil-Dri® Sweep	19 in. x 100 ft.	1 sweep/bale	13

Oil-Dri® Particulate

Melt-blown polypropylene.
Can be placed in hard-to-reach areas or thrown onto a spill.

Item No.	Description	Packaging
L90860	Oil-Dri® Particulate	25 lb. bag

Oil-Dri™ Peat Moss

Organic peat moss.
Biodegradable loose product, easily removable on water.

Item No.	Description	Packaging	Wt (lbs)
L90661	Oil-Dri™ Organic Peat Moss	30 bags/pallet	40

Oil-Dri™ Containment Booms

Item No.	Description	Dimensions	Packaging
L90739	Oil-Dri™ Containment Boom	6 in. float 12 in. skirt (top cable) 18 in. H	100 ft. section
L90741	Oil-Dri™ Containment Boom	6 in. float 1 2in. skirt (top cable) 18 in. H	100 ft. section
L90736	Oil-Dri™ Containment Boom	4 in. float 6 in. skirt (top cable) 10 in. H	100 ft. section
L90738	Oil-Dri™ Containment Boom	6 in. float 12 in. skirt (top cable) 18 in. H	50 ft. section
L90740	Oil-Dri™ Containment Boom	6 in. float 12 in. skirt 18 in.H	50 ft. section
L90737	Oil-Dri™ Containment Boom	4 in. float 6 in. skirt 10 in.H	50 ft. section

SPILL KITS

Oil-Dri™ Compact Spill Kits

MRO or Oil Only Spill Applications.
An easy and cost effective way to prepare for emergencies. These small kits are perfect for carrying in vehicles or placing in areas of the plant where spills are most likely.



Item No.	Description	Contents	Wt. (lbs)
L90671	Oil-Dri™ Smart Pak (MRO)	3 General Socks, 10 Universal Bonded Pads, 10 Wipes, 1 Disposal Bag, 1 Half-tub Plug n' Dike	5
L90430	Oil-Dri™ Marine Pak (Oil Only)	3 Poly Socks, 10 Smart Pads, 10 Wipes, 1 Disposal Bag, 1 Half-tub Plug n' Dike	5

Oil-Dri™ Trucker Spill Kits

MRO Spill Applications.
Ideal for on-board safety. Drivers can use for quick response to leaks and spills.



Item No.	Description	Contents	Wt. (lbs)
L90688	Oil-Dri® Trucker Spill Kit	3 General Socks, 25 Universal Bonded Pads, 1 Half-tub Plug n' Dike, 3 Disposal Bags, 1 Pair Protective Gloves, Safety Goggles	10

Oil-Dri™ MRO Split Kit

MRO Spill Applications
Ideal for Large Spills.



Item No.	Description	Contents	Wt. (lbs)
L90667	Oil-Dri™ MRO Spill Kit (95 Gallon)	16 General Socks (3 in.D x 48 in.L), 10 General Socks (3 in.D x 120 in.L), 8 General Pillows, 60 Universal Bonded Pads, 10 Disposal Bags with Ties, Emergency Response Guide Book, Overpack (95 gallon)	135
L90410	Oil-Dri™ MRO Spill Kit (20 Gallon)	4 General Socks (3 in.D x 48 in.L), 1 General Sock (3 in.D x 120 in.L), 2 General Pillows, 10 Universal Bonded Pads, 3 Disposal Bags with Ties, Emergency Response Guide Book, Overpack (20 gallon)	28

Oil-Dri™ Haz Mat Spill Kit

Haz Mat Spill Applications.



- continues -

Maintenance, Repair & Operations

Oil Dry®/Precision Brand®

Oil-Dri™ Haz Mat Spill Kit (continued)

Item No.	Description	Contents	Wt. (lbs)
L90415	Oil-Dri™ Haz Mat Spill Kit (95 Gallon)	12 Haz Mat Socks (3 in.D x 48 in. L.), 9 Haz Mat Socks (3 in.D x 120 in.L.), 7 Haz Mat Pillows, 1 4lb. Bag of Haz Mat Pulp, 60 Universal Bonded Pads, 10 Disposal Bags with Ties, Emergency Response Guide Book, Overpack (95 gallon)	95
L90894	Oil-Dri™ Haz Mat Spill Kit (20 Gallon)	6 Haz Mat Socks (3 in.D x 48 in.L.), 1 4lb. Bag of Haz Mat Pulp, 20 Universal Bonded Pads, 1 Pair Protective Gloves, 1 Lite Stick, 3 Disposal Bags with Ties, Emergency Response Guide Book, Overpack (20 gallon)	18

Oil-Dri™ Oil Only Spill Kit

Oil Only Spill Applications

Item No.	Description	Contents	Wt. (lbs)
L90943	Oil-Dri™ Oil Only Spill Kit (95 Gallon)	10 Booms 510, 60 Smart Pads, 10 Temporary Disposal Bags with Ties, Emergency Guide Book, Overpack (95 gallon)	95
L90942	Oil-Dri™ Oil Only Spill Kit (20 Gallon)	2 Booms 510, 20 Smart Pads, 3 Temporary Disposal Bags with Ties, Emergency Response Guide Book, Overpack (20 gallon)	26
L90420	Oil-Dri™ Ship Spill Kit (415 Gallon)	4 Booms (8 in. x 10 ft. L.), 10 Pillows (8 in. D x 18 in. L.), 1 Roll (30 in.W x 150 ft.L.), 100 Pads (3/8 in. D x 16 in. W x 20 in. L.), 200 Pads (3/16 in. D x 16 in. W x 20 in. L.), Non-Sparking Shovel, 4 Non-Sparking Scoops, Non-Sparking Scraper, Squeegee with Handle, Mop with Handle, 1 Gallon of Emulsifier, 6 Protective Suits, 100 Disposal Bags with Ties, Emergency Response Guide Book, Shipboard Container (50 in. D x 42 in. W x 44 in. L)	323

Precision Brand®

KEYSTOCK

Metric Keystock

- PRECISION BRAND Metric Keystock is used to accommodate metric keyways
- True metric keystock that conforms to metric keyway specifications
- Material is high quality, cold drawn steel, C1020 to C1045
- It is available in square and rectangular sizes
- Gold dichromate plating on most sizes makes product identification easy
- Stocked in 12" lengths, meter and special lengths also available
- Sizes are clearly stamped on each piece
- Special orders available for other sizes
- All sizes meet ISO R773 and BS 4235
- Most sizes meet DIN 6880



Millimeter Size (mm)	Bundle UPC No.	Pcs. Per Bdl.
2*	04000	6
3*	04005	6
4	04010	6
5	04015	6
6	04020	6
7	04025	6
8	04030	6
10	04035	4
12	04040	4
14	04045	4
16	04050	4
18	04055	4
20	04060	1
22	04065	1
25*	04070	1

*Only available in plain finish

Millimeter Size Width x Thkns (mm)	Bundle UPC No.	Pcs. Per Bdl.
8 x 7	05020	6
10 x 8	05035	6
12 x 8	05040	6
14 x 9	05050	6
12 x 10	05060	4
16 x 10	05065	4
18 x 11	05070	4
20 x 12	05075	4
22 x 14	05080	4
25 x 14	05085	4
28 x 16	05090	4
32 x 18	05095	4
36 x 20	05100	1
40 x 22*	05105	1
45 x 25*	05110	1
50 x 28*	05115	1

*Only available in plain finish

Steel Keystock



- PRECISION BRAND Keystock is used to provide driving torque between shafts and pulleys, gears, sprockets, etc.
- Used for new machinery, general maintenance and shop repairs
- It is a necessity in all applications where rotating power devices are used
- PRECISION BRAND Steel Keystock is available in square and rectangle sizes
- Stocked in 12" and 36" lengths
- Cut-to-length sizes in other lengths over 12" and up to 12 feet are available on special order by the piece
- Sizes are clearly marked on each piece
- Material is high quality, cold drawn, low carbon C1018 steel except for 5/32", 7/32" and 9/32"
- 5/32", 7/32" and 9/32" Square Keystock material is a 1215 steel
- Meets ASTM A-108
- Tolerance on dimensions are oversized to assure tight fits in keyways for positive, zero backlash power transmission
- Plain Keystock (unplated) is also available on special order

Size	Square	Rectangular
3/32 to 3/4	+0.003/-0	+0.004/-0
13/16 to 1-1/2	+0.004/-0	+0.005/-0
1-3/4 to 1-1/2	+0.005/-0	-

Fraction	Size Metric/mm	Bundle UPC No.	Pcs. Per Bdl.
3/32	2.38	14125	10
1/8	3.18	14150	10
5/32	3.97	14175	10
3/16	4.76	14200	6
7/32	5.56	14225	6
1/4	6.35	14250	6
9/32	7.14	14275	6
5/16	7.94	14300	6
3/8	9.53	14325	6
7/16	11.11	14350	4
1/2	12.70	14375	4
9/16	14.29	14400	4
5/8	15.88	14425	4
11/16	17.46	14430	4
3/4	19.05	14450	4
13/16	20.64	14460	4
7/8	22.23	14475	4
1	25.40	14500	4
1-1/8	28.58	14525	2
1-3/16	30.16	14550	2
1-1/4	31.75	14575	2
1-3/8	34.93	14600	2
1-1/2	38.10	14625	2
1-3/4	44.45	14650	1
2	50.80	14675	1

Fraction (in)	Size Metric/mm	Bundle UPC No.	Pcs. Per Bdl.
1/8 x 3/16	3.18 x 4.76	15125	6
1/8 x 1/4	3.18 x 6.35	15150	6
1/8 x 3/8	3.18 x 9.53	15175	6
3/16 x 1/4	4.76 x 6.35	15200	6
3/16 x 5/16	4.76 x 7.94	15225	6
3/16 x 3/8	4.76 x 9.53	15250	6
3/16 x 1/2	4.76 x 12.70	15275	6
1/4 x 5/16	6.35 x 7.94	15300	6
1/4 x 3/8	6.35 x 9.53	15325	6
1/4 x 1/2	6.35 x 12.70	15350	6
5/16 x 3/8	7.94 x 9.53	15375	6
5/16 x 1/2	7.94 x 12.70	15400	6
5/16 x 5/8	7.94 x 15.88	15425	6
3/8 x 1/2	9.53 x 12.70	15450	6
3/8 x 5/8	9.53 x 15.88	15475	6
3/8 x 3/4	9.53 x 19.05	15500	6
7/16 x 1/2	11.11 x 12.70	15515	6
1/2 x 5/8	12.70 x 15.88	15525	6
1/2 x 3/4	12.70 x 19.05	15550	6
5/8 x 3/4	15.88 x 19.05	15575	4
5/8 x 1	15.88 x 25.40	15600	4
3/4 x 1	19.05 x 25.40	15625	4

24 Maintenance Repair Operations

Maintenance, Repair & Operations

Precision Brand®

Stainless Keystock

- PRECISION BRAND Stainless Steel Keystock is an excellent alternative to Steel Keystock when corrosion resistance is a concern
- Frequently used in food and marine applications
- Made from 303/304 Stainless Steel
- Most tolerances on dimensions are undersized
- Tensile Strength 80,000 to 90,000 psi
- Rockwell Hardness: RB 80-95
- Elongation can be 45 to 65 percent in 2 inches
- Stocked in 12" lengths



12" Square Stainless Keystock			
Size Fraction	Metric/mm	Piece UPC No.	Pc. Lb. Wgt.
1/8	3.18	57501	.05
3/16	4.76	57502	.12
1/4	6.35	57503	.21
5/16	7.94	57504	.33
3/8	9.53	57505	.48
7/16	11.11	57506	.65
1/2	12.70	57507	.85
5/8	15.88	57508	1.33
3/4	19.05	57509	1.91
7/8	22.23	57510	2.60
1	25.40	57511	3.40

12" Rectangular Stainless Keystock			
Size Fraction	Metric/mm	Piece UPC No.	Pc. Lb. Wgt.
3/16 x 1/2	4.76 x 12.70	53501	.32
1/4 x 1/2	6.35 x 12.70	53502	.43
3/8 x 1/2	9.53 x 12.70	53503	.64
3/8 x 3/4	9.53 x 19.05	53504	.96
1/2 x 3/4	12.70 x 19.05	53505	1.28
5/8 x 3/4	15.88 x 19.05	53506	1.59
5/8 x 1	15.88 x 25.40	53507	2.13
3/4 x 1	19.05 x 25.40	53508	2.55

Stainless Keystock Tolerances		
Size	Square	Rectangular
1/8 to 3/16	±.003	±.008
1/4	+0/- .002	±.008
5/16 to 7/16	+0/- .003	±.008
1/2 to 1	+0/- .004	±.010

12" Sq. Stainless Keystock Asst.			
UPC No. 57680			
Size	Qty.	Size	Qty.
3/16	4	3/8	4
1/4	4	7/16	4
5/16	4	1/2	4

Asst. Wgt. = 11.10 lbs.

MAINTENANCE KITS

- Handy kits for shop, toolroom or tool box
- Finest materials are conveniently packaged
- Ideally suited for maintenance needs that are constantly arising
- On hand when needed saves time and money
- Plastic compartment boxes are easy to store
- Refill packages are available
- Bulk quantities also available

Cotter Pins

UPC No. 12905/600 Pieces

Strong and flexible steel pins with one prong extended for easy insertion and bending. Pins also have chisel point ends.

Contents:

130	1/16" x 1"	150	3/32" x 1"
100	1/8" x 1-1/4"	100	3/32" x 1-3/4"
80	1/8" x 2"	40	5/32" x 2-1/2"



Housing Rings

UPC No. 12920/150 Pieces

Internal rings with tapered design maintains constant pressure to prevent slippage of axles, gears and bearings inside machinery.

Contents:

15	1/2"	10	1-1/16"
15	5/8"	10	1-1/8"
15	11/16"	10	1-1/4"
15	3/4"	5	1-3/8"
15	13/16"	5	1-1/2"
15	7/8"	5	1-5/8"
10	1"	5	1-3/4"

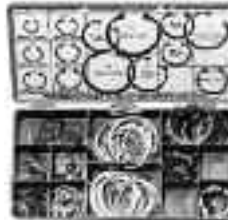

Retaining Rings

UPC No. 12935/140 Pieces

Similar to housing rings, these external rings accommodate components with large chamfers and radii.

Contents:

20	1/2"	15	3/4"
20	9/16"	10	7/8"
20	19/32"	10	1"
20	5/8"	10	1-1/4"
15	11/16"		



E-Clips

UPC No. 12910/265 Pieces

External clips made of carbon steel to retain positive retention of pulleys, sprockets, springs and bearings on shafts and rods.

Contents:

30	1/8"	30	3/8"
20	5/32"	25	7/16"
30	3/16"	20	1/2"
20	7/32"	15	5/8"
30	1/4"	10	3/4"
30	5/16"	5	7/8"



Roll Pins

UPC No. 12925/300 Pieces

Made of flexible spring steel, cold rolled, hardened and tempered. Chamfered ends simplify insertion.

Contents:

1/16", 5/64", 3/32", 1/8", 5/32", 3/16", 7/32", 1/4", 5/16" and 3/8" diameters	
Four (4) lengths included for each diameter.	



Woodruff Keys

UPC No. 12940/250 Pieces

Precise, zinc plated steel keys used for pulleys and drive shaft applications.

Contents:

10-1/16" x 3/8"	5-3/16" x 5/8"
20-3/32" x 3/8"	20-1/8" x 3/4"
10-1/8" x 3/8"	10-5/32" x 3/4"
10-1/16" x 1/2"	20-3/16" x 3/4"
20-3/32" x 1/2"	5-1/4" x 3/4"
20-1/8" x 1/2"	5-5/32" x 7/8"
10-3/32" x 5/8"	5-3/16" x 7/8"
30-1/8" x 5/8"	5-7/32" x 7/8"
40-5/32" x 5/8"	5-1/4" x 7/8"



Snap Rings

UPC No. 12900/300 Pieces

External, spring steel snap rings used to retain pulleys, gears or wheels on shafts.

Contents:

30	1/4"	30	5/8"
20	5/16"	35	3/4"
50	3/8"	10	13/16"
20	7/16"	20	7/8"
50	1/2"	10	1"
20	9/16"	5	1-1/4"



Hitch Pin Clips

UPC No. 12915/150 Pieces

Reusable, quick release pins for fast assembly and disassembly. Made of spring steel to maintain tension.

Contents:

60	1/16"	#18
30	3/32"	#3
20	3/32"	#7
20	1/8"	#16
15	5/32"	#10
5	3/16"	#6

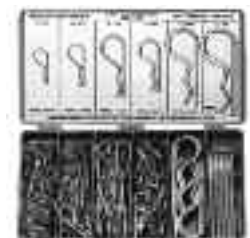

Precision Brand®

O Rings

UPC No. 12930/300 Pieces

Made of BUNA-N 70 durometer rubber compound. Creates a tight seal for fluid or gas connections.

Contents:

140 pcs. of 1/16" body
80 pcs. of 3/32" body
80 pcs. of 1/8" body
Various sizes are included for each body size.



Grease Fittings

UPC No. 12945/90 Pieces

These push type plated fittings permit lubricant to flow while built-in ball, under spring pressure, prevents dirt from entering.

Contents:

30 1/4" 28-Straight
10 1/4" 28-45°
10 1/4" 28-90°
30 1/8" NPT-Straight
5 1/8" NPT-45°
5 1/8" NPT-90°



Set Screws

UPC No. 12950/200 Pieces

High-grade alloy steel setscrews with hexagon recessed heads. Ends have cup points for positive torque.

Contents:

10 6-32 x 3/16"	30 5/16"-18 x 3/8"
10 8-32 x 3/16"	20 5/16"-24 x 3/8"
10 10-24 x 1/4"	20 5/16"-18 x 1/2"
30 1/4"-20 x 1/4"	10 3/8"-16 x 3/8"
20 1/4"-28 x 1/4"	10 3/8"-24 x 3/8"
20 1/4"-20 x 3/8"	10 3/8"-16 x 1/2"



Socket Head Cap Screws

UPC No. 12970/190 Pieces

High-grade alloy steel socket head screws with hexagon recessed heads.

Contents:

10 6/32" x 1/2"	10 1/4"-20 x 1/2"
10 6/32" x 1"	10 1/4"-20 x 3/4"
10 8/32" x 1/2"	10 1/4"-20 x 1"
10 8/32" x 3/4"	10 1/4"-20 x 1-1/4"
10 8/32" x 1"	10 1/4"-20 x 1-1/2"
10 10/32" x 1/2"	10 1/4"-28 x 3/4"
10 10/32" x 3/4"	10 1/4"-28 x 1"
10 10/32" x 1"	10 1/4"-28 x 1-1/4"
10 10/24" x 1/2"	10 1/4"-28 x 1-1/2"
10 10/24" x 1"	



Electrical Terminals

UPC No. 12985/175 Pieces

High quality, American made terminals and connectors for industrial and automotive applications.

Contents:

30 Butt Connectors
20 Insulated Quick Slide Terminals
20 Non-Insulated Quick Slide Terminals
5 Self-Splicing Connectors
40 Spade Terminals
60 Ring Terminals



Machinery Keys

UPC No. 12955/58 Pieces

Zinc plated steel, square keys have chamfered ends for easy insertion into keyways.

Contents:

3 1/8" x 1/8" x 3/4"	5 1/4" x 1/4" x 1-1/2"
3 1/8" x 1/8" x 1"	5 5/16" x 5/16" x 1-1/4"
5 3/16" x 3/16" x 3/4"	5 5/16" x 5/16" x 1-1/2"
5 3/16" x 3/16" x 1"	5 3/8" x 3/8" x 1-1/4"
5 3/16" x 3/16" x 1-1/4"	5 3/8" x 3/8" x 1-1/2"
5 1/4" x 1/4" x 3/4"	2 1/2" x 1/2" x 1-1/2"
5 1/4" x 1/4" x 1-1/4"	

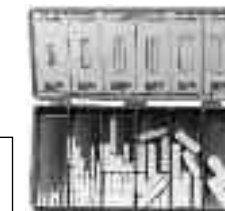

Metric Set Screws

UPC No. 12975/375 Pieces

High-grade alloy steel metric setscrews with hexagon recessed heads. Ends have cup points for positive torque.

Contents:

25 M3 x 0.5mm x 3mm	25 M5 x 0.8mm x 12mm
25 M3 x 0.5mm x 6mm	25 M6 x 1.0mm x 6mm
25 M3 x 0.5mm x 10mm	25 M6 x 1.0mm x 8mm
25 M4 x 0.7mm x 4mm	25 M6 x 1.0mm x 10mm
25 M4 x 0.7mm x 6mm	25 M8 x 1.25mm x 8mm
25 M4 x 0.7mm x 10mm	25 M8 x 1.25mm x 12mm
25 M5 x 0.8mm x 5mm	25 M8 x 1.25mm x 16mm
25 M5 x 0.8mm x 8mm	



Taper Pins

UPC No. 12907/100 Pieces

Made from 1215 & 12L14 steel. These pins are mainly used for hole alignment in maintenance machinery. They are tapered 1/4" per foot.

Contents:

#0, #1, #2, #3, #4, #5, and #6 sizes included.
Available in 10 different lengths from 3/4" to 3".



Plastic Hose Clamps

UPC No. 12965/146 Pieces

These clamps are heat stabilized for motor applications, lightweight & corrosion resistant.

Contents:

12 .228" x .256"	10 .702 x .801"
12 .307" x .342"	10 .779" x .899"
12 .351" x .394"	8 .859" x .989"
12 .404" x .452"	8 .928" x 1.072"
12 .449" x .511"	6 .985" x 1.135"
12 .513" x .586"	6 1.123" x 1.296"
10 .569" x .650"	6 1.218" x 1.405"
10 .616" x .707"	



Metric Socket Head Cap Screws

UPC No. 12980/255 Pieces

High-grade alloy steel metric cap screws with hexagon recessed heads.

Contents:

25 M4 x 0.7mm x 10mm	10 M6 x 1.0mm x 20mm
25 M4 x 0.7mm x 12mm	10 M6 x 1.0mm x 25mm
25 M4 x 0.7mm x 20mm	10 M6 x 1.0mm x 30mm
25 M4 x 0.7mm x 25mm	10 M6 x 1.0mm x 40mm
25 M5 x 0.8mm x 12mm	10 M8 x 1.25mm x 20mm
25 M5 x 0.8mm x 20mm	10 M8 x 1.25mm x 25mm
10 M5 x 0.8mm x 25mm	10 M8 x 1.25mm x 30mm
10 M5 x 0.8mm x 30mm	3 M8 x 1.25mm x 40mm
10 M6 x 1.0mm x 12mm	2 M8 x 1.25mm x 45mm



Dowel Pins

UPC No. 12912/176 Pieces

Made from alloy steel, these pins have a plain finish and are used to retain parts in a fixed position or to preserve alignment when extreme accuracy is required. Meets ANSI B18.8.2

Contents:

1/16", 1/8", 3/16", 1/4", 5/16", 3/8", and 1/2" diameters included. Available in different lengths from 3/8" to 2".

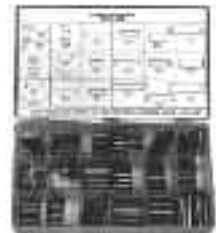

Maintenance, Repair & Operations

Precision Brand®

Stainless Steel Woodruff Keys

UPC No. 13970/66 Pieces

Precise, 316 stainless steel keys used for pulley and drive shaft applications where corrosion resistance is a factor.

Contents:

5 1/16" x 3/8"	4 3/16" x 5/8"
5 3/32" x 3/8"	4 1/8" x 3/4"
5 1/8" x 3/8"	4 5/32" x 3/4"
5 1/16" x 1/2"	4 3/16" x 3/4"
5 3/32" x 1/2"	4 1/4" x 3/4"
5 1/8" x 1/2"	3 3/16" x 7/8"
4 1/8" x 5/8"	3 1/4" x 7/8"
4 5/32" x 5/8"	2 1/4" x 1"



Clevis Pins

UPC No. 13965/83 Pieces

Pins are made from cold formed 1008 to 1018 low carbon steel. Plated finish extends life and chamfered hole allows for easy insertion.

Contents:

6 3/16" x 1"	4 5/16" x 1-3/4"
7 1/4" x 1"	3 5/16" x 2"
4 1/4" x 1-1/4"	2 5/16" x 2-1/4"
7 1/4" x 1-1/2"	2 5/16" x 2-1/2"
4 1/4" x 1-3/4"	2 5/16" x 2-3/4"
6 1/4" x 2"	5 3/8" x 1"
3 1/4" x 2-1/4"	4 3/8" x 1-1/2"
3 1/4" x 2-1/2"	2 3/8" x 2"
6 5/16" x 1"	2 1/2" x 1-1/2"
4 5/16" x 1-1/4"	2 1/2" x 2"
5 5/16" x 1-1/2"	



Metric Grease Fittings

UPC No. 13975/95 Pieces

These metric size push type plated fittings permit lubricant to flow while built-in ball, under spring pressure, prevents dirt from entering.

Contents:

20 6mm x 1mm x Straight	10 8mm x 1mm x 90°
10 6mm x 1mm x 45°	5 10mm x 1mm x Straight
10 6mm x 1mm x 90°	5 10mm x 1mm x 45°
20 8mm x 1mm x Straight	5 10mm x 1mm x 90°
10 8mm x 1mm x 45°	



Metric Roll Pins

UPC No. 12960/287 Pieces

Made of flexible spring steel, cold rolled, hardened and tempered. Chamfered ends simplify insertion. All sizes in millimeters.

Contents:

Includes 1.5, 2, 3, 4, 5, 6, 8, and 10 millimeter diameters in various lengths from 6 to 80 millimeters



FEELER/THICKNESS GAGE

Steel Feeler Gage

- PRECISION BRAND Feeler Gage is made from Spring Steel stock, close grain C1095 high carbon steel
- Hardened and tempered to RC 48-62
- Material is ground and polished to precision tolerances
- Used in manufacturing and maintenance operations wherever setting close spacing or checking extremely tight tolerances is required
- Thicknesses are clearly etched every 6" in decimal and metric
- Feeler Gage stock is packaged in 5" or 12" flat lengths, 25 feet coils and in convenient assortments
- Also available in bulk quantities
- Other sizes or dimensions are available for special order i.e. metric sizes
- Meets FED-GGG-G-17C



TYPICAL C .90 - 1.04, Mn .30 - .50,
ANALYSIS: P .035 max., S .040 max.,
Si .15 - .30

- continues -

Steel Feeler Gage (continued)

Feeler Gage			
Thickness		12' Lengths 25' Coils	
Decimal	Metric/mm	UPC No.*	UPC No.
.001	.025	19120	19125
.0015	.038	19145	19150
.002	.051	19170	19175
.0025	.064	19185	19190
.003	.076	19210	19215
.004	.102	19235	19240
.005	.127	19260	19265
.006	.152	19285	19290
.007	.178	19310	19315
.008	.203	19335	19340
.009	.229	19360	19365
.010	.254	19385	19390
.011	.279	19400	19405
.012	.305	19425	19430
.013	.330	19440	19445
.014	.356	19465	19470
.015	.381	19490	19495
.016	.406	19515	19520
.017	.432	19530	19535
.018	.457	19555	19560
.019	.483	19570	19575
.020	.508	19595	19600
.021	.533	19610	19615
.022	.559	19635	19640
.023	.584	19650	19655
.024	.610	19675	19680
.025	.635	19700	19705
.028	.711	19715	19720
.030	.762	19730	19735
.031	.787	19745	19750
.032	.813	19760	19765
.034	.864	19775	19780

* 12 pieces per box

Flat Length Feeler Gage

- 12" long x 1/2" wide
- 12" lengths are individually wrapped for protection and convenience
- Ends are rounded and edges are smooth for safety
- Each piece has a 3/16" hole at one end

Coiled Feeler Gage

- 25 feet long x 1/2" wide
- Each coil is conveniently packaged in shrink-wrapped dispensers
- Easily cut to desired length

Feeler Gage	
Decimal Thickness	Tolerance
.001	±.00012
.0015-.007	±.00020
.008-.009	±.00025
.010-.012	±.00035
.013-.015	±.00043
.016-.019	±.00047
.020-.024	±.00055
.025-.031	±.00067
.032-.034	±.00075
Width Tolerance	±.005

STEEL FEELER GAGE ASSORTMENTS:

Poc-Kit® Assortment

- Contains twenty 5" long x 1/2" wide blades
- Packaged in a sturdy, vinyl case
- Individual blade pockets
- Conveniently folds flat
- Each blade is clearly etched with size in metric and decimal
- Ends are rounded and edges are smooth for safety
- Vinyl case helps prevent rust and extends blade life

Poc-Kit® Assortment			
UPC No. 19740			
20 Thicknesses - (Decimal):			
.001	.005	.010	.018
.0015	.006	.012	.020
.002	.007	.014	.022
.003	.008	.015	.024
.004	.009	.016	.025



Fan Blade Type Feeler Gage Sets

UPC No. 19800

- Contains ten 3" long tapered blades
- Sturdy protective swivel holder
- Contents: .0015, .002, .003, .004, .006, .008, .010, .012, .015, .025,



UPC No. 19821

- Contains twenty-five 3" long by 1/2" wide blades
- Heavy-duty swivel holder
- Rounded ends for safety
- Sizes etched on each blade
- Contents: .0015, .002, .003, .004, .005, .006, .007, .008, .009, .010, .011, .012, .013, .014, .015, .016, .018, .020, .022, .024, .025, .028, .030, .032, .035



Precision Brand®

Stainless Steel Thickness Gage

- PRECISION BRAND Stainless Steel Thickness Gage is made from 300 Series Stainless Steel
- Used in manufacturing or maintenance of a technical nature where stringent, corrosion resistant and low magnetism material is needed to check extremely tight tolerances or close spacing
- Material is a good conductor and will withstand high temperatures
- Industries which use this product are aircraft, power/utility, food, automotive and marine
- Rockwell Hardness: 45 to 55 C Scale
- .001 to .031 blades have size etched on the material; .0005 blades have size stamped on blade package
- Bulk material also available
- See next page for poc-kit assortment
- Other thicknesses available on special order

Stainless Steel Thickness Gage		
Decimal Thkns	Tolerances	
.0005 & .001	±.0001	
.0015	±.00012	
.002	±.00016	
.003 & .004	±.0002	
.005 & .006	±.00024	
.007	±.00028	
.008 & .009	±.00031	
.010 & .012	±.00035	
.015	±.00043	
.020	±.00055	
.025	±.00067	
.031	±.0016	
Width	±.005	

Stainless Steel Thickness Gage			
Thickness		12" Lengths	
Decimal	Metric/mm	UPC No.*	
.0005	.013	77740	
.001	.025	77120	
.0015	.038	77145	
.002	.051	77170	
.003	.076	77210	
.004	.102	77235	
.005	.127	77260	
.006	.152	77285	
.007	.178	77310	
.008	.203	77335	
.009	.229	77360	
.010	.254	77385	
.012	.305	77425	
.015	.381	77490	
.020	.508	77595	
.025	.635	77770	
.031	.787	77730	

*12 pcs. per box

Brass Thickness Gage

- PRECISION BRAND Brass Thickness Gage is made from a 260 CDA Alloy
- Used in manufacturing & maintenance of highly technical markets where non-magnetic, and non-corrosive product would be needed to check extremely close spacing
- When inserted material should not cause a spark
- Ideal industries: computer, mining & electronics
- Blades have size etched every 6" in decimal and metric
- Rockwell Hardness: 30T Scale 56-78
- Bulk material also available
- See next page for poc-kit assortment
- Other thicknesses available on special order

Brass Thickness Gage		
Thickness	12" Lengths	
Decimal	Metric/mm	UPC No.*
.001	.025	76120
.0015	.038	76145
.002	.051	76170
.003	.076	76210
.004	.102	76235
.005	.127	76260
.006	.152	76285
.007	.178	76310
.008	.203	76335
.009	.229	76360
.010	.254	76385
.012	.305	76425
.014	.356	76465
.015	.381	76490
.016	.406	76515
.018	.457	76555
.020	.508	76595
.022	.559	76635
.024	.610	76675
.025	.635	76700
.030	.762	76730
.032	.813	76760

*12 pcs. per box

Brass Thickness Gage		
Decimal Thkns.	Tolerances	
.001 & .003	±10%	
.004 & .006	±.0005	
.007 & .009	±.0006	
.010 to .014	±.0008	
.015 to .024	±.001	
.025 to .032	±.002	
Width	±.005	

Brass Thickness Gage Poc-Kit®

- Contains twenty 5" x 1/2" wide blades
- Packaged in a sturdy vinyl case with individual blade pockets
- Conveniently folds flat
- Each blade is clearly etched with thickness
- Ends are rounded and edges are smooth for safety
- Vinyl case helps extend blade life

Brass Thickness Gage Poc-Kit Assortment			
UPC No. 76740			
20 Thicknesses-Decimal			
.001	.005	.010	.018
.0015	.006	.012	.020
.002	.007	.014	.022
.003	.008	.015	.025
.004	.009	.016	.030



Stainless Steel Thickness Gage Poc-Kit®

- Contains twenty 5" long x 1/2" blades
- Contains sixteen different thicknesses; duplicate blades have been included on the four most commonly used thicknesses
- Packaged in a sturdy vinyl case with individual blade pockets
- Conveniently folds flat
- Each blade is clearly etched with thickness
- Ends are rounded and edges are smooth for safety
- Vinyl case helps extend life

Stainless Steel Thickness Gage Poc-Kit Assortment			
UPC No. 77750			
16 Thicknesses / 20 Pieces-Decimal			
.001	.004	.008	.015
.0015	.005	.009	.020
.002	.006	.010	.025
.003	.007	.012	.031



Plastic Thickness Gage

- Contains thirteen blades riveted together for on-site convenience
- Made of the highest quality plastic material
- .001" - .005 Polyester
- .0075" - .030" Vinyl
- Available in 5" & 12" lengths
- Color indicates thickness
- Packaged in a sturdy vinyl case
- Non-corrosive, non-conductive, non-sparking, and non-marring
- Individual blades also available on special order



Plastic Thickness Gage	
UPC No.	Description
78905	5" Fan Blade Set
78900	12" Fan Blade Set

Thirteen Thicknesses-Decimal/Color		
.001"/Amber	.005"/Blue	.020"/Yellow
.0015"/Purple	.0075"/Matte	.025"/White
.002"/Red	.010"/Brown	.030"/Coral
.003"/Green	.0125"/Black	
.004"/Tan	.015"/Pink	

Maintenance, Repair & Operations

Precision Brand®

WIRE

Music & Stainless Steel Wire

- PRECISION BRAND Music Wire is spring tempered and made from high carbon steel alloy
- Has high tensile strength and high fatigue resistance
- Tensile strength from 245,000 psi to 455,000 psi (245-455 ksi)
- Applications include springs, wire forms, control linkages, armature binding, ceramic cutting and a variety of industrial uses
- Available in one pound or quarter pound rolls from .006" to .180"
- Meets ASTM A-228

TYPICAL C .70-1.00, Mn .20-.60,
ANALYSIS: P .025 max. S .030 max.,
Si .10-.30



MUSIC WIRE		
Decimal	Thkns	Tolerance
.006-.010		±.0002
.011-.026		±.0003
.029-.063		±.0004
.064-.080		±.0005
.081-.180		±.001

- PRECISION BRAND Stainless Steel Spring Wire is spring tempered, full hard, TYPE 302 Stainless Steel wire
- Tensile strength from 194,000 psi to 355,000 psi (194-355 ksi)
- Excellent corrosion resistant qualities and smooth finish
- Same applicators as Music Wire
- Available in one pound rolls from .006" to .187"
- Meets ASTM A-555, AMS 5688 and ASTM A-313-92, ASTM-A-580

TYPICAL C .15 max., Mn 2.00 max.,
ANALYSIS: Si 1.00 max. Ni 8.00-10.00,
P .045 max., S .030 max.,
Cr 17.00-19.00, N .10 max

Stainless Steel Wire		
Decimal	Thkns	Tolerance
.006 - .007		±.0002
.008 - .011		±.0003
.012 - .022		±.0004
.024 - .031		±.0005
.033 - .043		±.0008
.044 - .187		±.001

WIRE								
Diameter		Approx. Ft. Per. Lb.	Wire Gauge No.	Music Wire			Stainless Steel	
Dec-imal	Metric mm			Tensile Strength (ksi) min-max	1 lb. UPC No.	1/4 lb. UPC No.	Tensile Strength (ksi) min-max	1 lb. UPC No.
.006	.152	10,404	4/0	415-455	21006	21206	325-355	29006
.007	.178	7,644	3/0	407-447	21007	21207	325-355	29007
.008	.203	5,853	2/0	399-434	21008	21208	325-355	29008
.009	.229	4,624	1/0	393-428	21009	21209	325-355	29009
.010	.254	3,746	1	387-422	21010	21210	320-350	29010
.011	.279	3,096	2	382-417	21011	21211	318-348	29011
.012	.305	2,601	3	377-412	21012	21212	316-346	29012
.013	.330	2,217	4	373-408	21013	21213	314-344	29013
.014	.356	1,911	5	369-404	21014	21214	312-342	29014
.016	.406	1,464	6	362-392	21016	21216	308-338	29016
.018	.457	1,156	7	356-386	21018	21218	304-334	29018
.020	.508	937	8	350-380	21020	21220	300-330	29020
.022	.559	774	9	345-375	21022	21222	296-326	29022
.024	.610	651	10	341-371	21024	21224	292-322	29024
.026	.660	555	11	337-367	21026	21226	291-320	29026
.029	.737	446	12	333-363	21029	21229	285-315	29029
.031	.787	390	13	330-360	21031	21231	285-315	29031
.033	.838	344	14	327-357	21033	21233	282-310	29033
.035	.889	306	15	324-354	21035	21235	280-308	29035
.037	.940	274	16	321-351	21037	21237	280-308	29037
.039	.991	247	17	318-348	21039	21239	275-304	29039
.041	1.041	223	18	315-345	21041	21241	275-304	29041
.043	1.092	203	19	313-343	21043	21243	272-300	29043
.045	1.143	185	20	309-339	21045	21245	272-300	29045
.047	1.194	170	21	309-339	21047	21247	-	-
.0475	1.207	166	-	-	-	-	267-295	29047
.049	1.245	156	22	306-336	21049	21249	-	-
.050	1.270	150	-	-	-	-	267-295	29050
.051	1.295	144	23	303-333	21051	21251	265-293	29051
.055	1.397	124	24	300-330	21055	21255	261-289	29055
.059	1.499	108	25	296-326	21059	21259	258-285	29059
.0625	1.588	97	-	-	-	-	258-285	29062
.063	1.600	95	26	293-323	21063	21263	-	-
.067	1.701	84	27	290-320	21067	21267	252-281	29067
.071	1.803	75	28	290-320	21071	21271	-	-
.072	1.829	73	-	-	-	-	250-278	29072
.075	1.905	67	29	287-317	21075	21275	-	-
.078	1.981	62	-	-	-	-	246-275	29078
.080	2.032	59	30	282-312	21080	21280	246-275	29080

Music & Stainless Steel Wire (continued)

WIRE								
Diameter		Approx. Ft. Per. Lb.	Wire Gauge No.	Music Wire			Stainless Steel	
Dec-imal	Metric mm			Tensile Strength (ksi) min-max	1 lb. UPC No.	1/4 lb. UPC No.	Tensile Strength (ksi) min-max	1 lb. UPC No.
.085	2.159	52	31	279-308	21085	21285	242-271	29085
.090	2.286	47	32	276-305	21090	21290	238-268	29090
.095	2.413	42	33	274-303	21095	21295	238-268	29095
.100	2.540	37	34	271-300	21100	-	232-262	29100
.105	2.667	34	-	-	-	-	232-262	29105
.106	2.692	33	35	270-299	21106	-	-	-
.109	2.769	31	-	-	-	-	227-257	29109
.112	2.845	30	36	266-294	21112	-	-	-
.118	2.997	27	37	266-294	21118	-	-	-
.120	3.048	26	-	-	-	-	222-263	29120
.125	3.175	24	1/8"	261-288	21125	-	222-263	29125
.128	3.251	23	-	-	-	-	217-248	29128
.130	3.302	22	39	259-286	21130	-	-	-
.135	3.429	20	-	-	-	-	217-248	29135
.138	3.505	19	40	258-285	21138	-	-	-
.146	3.708	18	41	254-281	21146	-	-	-
.148	3.759	17	-	-	-	-	210-241	29148
.154	3.912	16	42	253-279	21154	-	-	-
.156	3.962	15	-	-	-	-	205-235	29156
.162	4.115	14	43	249-275	21162	-	205-235	29162
.170	4.318	13	44	249-275	21170	-	-	-
.177	4.496	12	-	-	-	-	198-228	29177
.180	4.572	11	45	245-270	21180	-	-	-
.187	4.750	10	-	-	-	-	194-225	29187

- All wire is available in cut and straightened lengths and in bulk quantities as a special order
- All packaged wire is shrink-wrapped and bar coded. .006 to .078 are packaged in easy to use pull-type dispensers boxes

SHIMS

Steel Shim

- PRECISION BRAND Steel Shim Shock is a full hard, cold rolled, low carbon 1010
- Rockwell hardness RB90-100
- Meets ASTM A-109, AISI 1010
- Approx. Tensile Strength: 80,000 p.s.i.
- #2 Bright Finish

TYPICAL C .08-.13, Mn .30-.60,
ANALYSIS: P .03 max., S .035 max.



Steel Shim Tolerances			
Decimal	Thkns	6" Width	12" Width
.001-.003		±10%	±10%
.0035-.006		±.0005	±.0005
.007-.018		±.00075	±.00075
.020-.025		±.001	±.001
.031		±.0015	±.0015
Width Tolerance		±.005	±.010

		Steel Shim Rolls		Steel Shim Flat Sheets†	
Thkns	Metric/mm	6" x 100" UPC No.	Wt. (lbs)	6" x 18" UPC No.*	Wt. (lbs)
.001	.025	16130	.25	16810	.63
.0015	.038	16155	.26	16815	.75
.002	.051	16195	.42	16820	.99
.0025	.064	16215	.43	16825	1.18
.003	.076	16245	.58	16830	1.25
.0035	.089	16265	.60	16835	1.37
.004	.102	16280	.72	16840	1.50
.005	.127	16320	.96	16845	1.63
.006	.152	16345	1.14	16850	2.13
.007	.178	16370	1.31	16855	2.45
.008	.203	16395	1.52	16860	2.75
.009	.229	16415	1.66	16865	2.99
.010	.254	16450	1.83	16870	3.38
.012	.305	16480	2.24	16875	3.93
.0135	.343	16500	2.30	16880	4.13
.015	.381	16530	2.76	16885	4.93
.0165	.419	16550	3.19	16890	5.05
.018	.457	16560	3.63	16895	5.93
.020	.508	16590	3.85	16900	6.50
.022	.559	16610	3.94	16905	6.73
.025	.635	16630	5.04	16910	8.00
.031	.787	16660	6.58	16915	9.93

* 10 Sheets per Pkg.
† Other dimensions available as a special order

Precision Brand®

Brass Shim

- PRECISION BRAND Brass Shim Stock is a half hard, cold rolled, CDA 260 alloy
 - Rockwell hardness 30T 56-68
 - Meets SAE-CA-260, ASTM B-19, B-36; CDA 260
 - Tensile Strength: 57-67,000 p.s.i.
 - Elongation: 23% in 2"
- TYPICAL ANALYSIS: Cu 70%-Zinc 30%

BRASS SHIM TOLERANCES		
Decimal Thkns	6" width	12" width
.001-.003	±10%	±10%
.004	±.0003	±.0006
.005-.006	±.0004	±.0008
.007-.009	±.0006	±.0010
.010-.013	±.0008	±.0013
.014-.017	±.0010	±.0015
.018-.021	±.0013	±.0018
.022-.031	±.002	±.002
Width Tolerance	±.008	±.008



Thickness	Brass Shim Rolls		Brass Shim Flat Sheets†		
	6" x 100"		6" x 18"		
Decimal	Metric/mm	UPC No.	Wt (lbs)	UPC No.*	Wt. (lbs)
.001	.025	17135	.29	17810	.63
.0015	.038	17160	.38	17815	.78
.002	.051	17195	.46	17820	1.13
.003	.076	17240	.64	17830	1.23
.004	.102	17265	.82	17840	2.00
.005	.127	17305	1.03	17845	1.94
.006	.152	17330	1.21	17850	2.25
.007	.178	17355	1.45	17855	2.63
.008	.203	17370	1.57	17860	2.91
.009	.229	17390	1.78	17865	2.98
.010	.254	17415	1.96	17870	3.63
.012	.305	17445	2.44	17875	4.25
.015	.381	17475	3.08	17885	5.44
.020	.508	17495	3.67	17900	7.00
.025	.635	17515	5.08	17910	8.69
.031	.787	17535	6.13	17915	10.63

* 10 sheets per pkg.
 † Other dimensions available as a special order

Slotted Shim

THE NEW SHAPE IN PRODUCTIVITY

- PRECISION BRAND Slotted Shim is the best way to solve alignment and leveling problems
- Slotted Shim works on motors, pumps, generators and other plant machinery
- These shims are economical, safe and accurate
- Available in four sizes to cover most applications
- Full line kits and replacement sizes are available



ECONOMICAL

- Reduces labor costs by eliminating hand cutting
- Prevents material waste
- 300 Series resists rust and corrosion
- Reduces downtime by eliminating shim preparation

SAFETY

- Tabs make the shim placement easier and safer
- Tabs eliminate need to place hands under machinery during installation or removal of shims

ENGINEERED FOR QUALITY

- Each shim marked with thickness in decimal and metric
- .001" to .010" sizes are permanently etched
- .015" to .125" sizes are permanently stamped
- Eliminates misalignment of expensive machinery
- Shim thickness tolerances meet industry standards
- Shims conform to standard bolt and stud sizes

- continues -

Slotted Shim (continued)

Slotted Shim Tolerances	
Decimal Thkns	Tolerance
.001	±.0008
.002	±.0001
.003	±.00015
.004	±.0002
.005	±.00025
.010-.020	±.0005
.025	±.00075
.050	±.001
.075 & .100	±.002
.125	±.0025

Slotted Shim Slot Sizes			
Size A	Size B	Size C	Size D
2" x 2"	3" x 3"	4" x 4"	5" x 5"
5/8"	3/4"	1-1/4"	1-5/8"

Slotted Shim Assortment Kits				
Kit Type	Size A	Size B	Size C	Size D
	2" x 2"	3" x 3"	4" x 4"	5" x 5"
UPC No. Wt. (lbs)	UPC No. Wt. (lbs)	UPC No. Wt. (lbs)	UPC No. Wt. (lbs)	UPC No. Wt. (lbs)
FULL ASSORTMENT-Each full assortment contains 20 pieces of the following sizes: .001, .002, .003, .004, .005, .010, .015, .020, .025, .050, .075, .100, and .125. A full assortment kit contains 260 pieces and is packaged in a durable metal box.	42900 (11.7 lbs)	42910 (25.7 lbs)	42920 (43.2 lbs)	42930 (62.5 lbs)
MINI ASSORTMENT-Each mini assortment contains 10 pieces of the following sizes: .001, .002, .003, .004, .005, .010, .015, .020, .025, .050, .075, .100, and .125. A mini assortment kit contains 130 pieces and is packaged in a durable metal box.	42940 (10.1 lbs)	42950 (16.6 lbs)	42960 (26.1 lbs)	42970 (36.8 lbs)
SHOP KIT-Each shop kit contains 10 pieces of the following sizes: .001, .003, .005, .010, .015, .020, .025, .075. A shop kit contains 80 pieces and is packaged in a sturdy chipboard box.	42945 (3.7 lbs)	42955 (4.4 lbs)	42965 (6.6 lbs)	42975 (9.9 lbs)
METAL BOX ONLY (empty)	42901 (2.8 lbs)	42911 (4.9 lbs)	42921 (8.0 lbs)	42931 (9.8 lbs)

Slotted Shim Refill Packages										
Thickness		Size A 2" x 2"		Size B 3" x 3"		Size C 4" x 4"		Size D 5" x 5"		
Dec-imal	Metric mm	Pcs. Per Pkg.	UPC No.	Pkg. Wt (lbs)	UPC No.	Pkg. Wt. (lbs)	UPC No.	Pkg. Wt. (lbs)	UPC No.	Pkg. Wt. (lbs)
.001	.025	20	42205	.03	42305	.07	42405	.11	42505	.17
.002	.051	20	42210	.05	42310	.12	42410	.19	42510	.30
.003	.076	20	42215	.07	42315	.15	42415	.27	42515	.43
.004	.102	20	42220	.09	42320	.21	42420	.35	42520	.54
.005	.127	20	42225	.11	42325	.25	42425	.43	42525	.65
.010	.254	20	42230	.21	42330	.48	42430	.81	42530	1.28
.015	.381	10	42235	.16	42335	.38	42435	.65	42535	.99
.020	.508	10	42240	.22	42340	.49	42440	.85	42540	1.30
.025	.635	10	42245	.27	42345	.61	42445	1.05	42545	1.61
.050	1.27	5	42250	.27	42350	.61	42450	1.03	42550	1.66
.075	1.91	5	42255	.39	42355	.90	42455	1.53	42555	2.36
.100	2.54	5	42260	.51	42360	1.22	42460	2.07	42560	3.14
.125	3.18	5	42265	.63	42365	1.45	42465	2.48	42565	3.82

24
Maintenance
Repair
Operations

Maintenance, Repair & Operations

Precision Brand®

GROUND FLAT STOCK

Oil Hardening Ground Flat Stock

PRECISION BRAND Ground Flat Stock is made from general purpose tool steel.

- Ideal material for tools, dies, punches, templates, stripper plates and general precision machine parts.
- Material is oil hardening (0-1) grade
- Excellent machinability characteristics
- Pre-ground on all surfaces to close tolerances
- Ready for toolroom use
- An electric furnace melt tool steel
- Fully spheroidized structure
- Non-shrinking
- Meets ASTM-A-681, SAE J-437

TYPICAL C .80 - .95, Mn 1.00 - 1.25,
ANALYSIS: Si .20 - .40, Cr .40 - .70,
V .10 - .20, W .40 - .60,
P .020 max., S .020 max.

0-1 HEAT TREATMENT

1. For section 1/4" and smaller, heat thoroughly to 1450-1475° F
2. For sections larger than 1/4", preheat to 1200° F, insert material, then raise to 1450-1500° F
3. Hold temperature for one-half hour per inch of cross section
4. Quench in oil at 125-150° F
5. TEMPER IMMEDIATELY

18" Lengths 0-1 Oil Hardening Ground Flat Stock

Size (in) Thkns	Width	UPC No.
1/16	1/2	30040
1/16	3/4	30041
1/16	1	30042
1/16	1-1/4	30043
1/16	1-1/2	30044
1/16	1-3/4	30045
1/16	2	30046
1/16	2-1/2	30047
1/16	3	30048
1/16	3-1/2	30049
1/16	4	30050
5/64	1/2	30060
5/64	3/4	30061
5/64	1	30062
5/64	1-1/2	30063
5/64	2	30064
3/32	1/2	30070
3/32	3/4	30071
3/32	1	30072
3/32	1-1/4	30073
3/32	1-1/2	30074
3/32	2	30075
3/32	2-1/2	30076
3/32	3	30077
7/64	1/2	30082
7/64	3/4	30083
7/64	1	30084
7/64	1-1/4	30085
7/64	1-1/2	30086
7/64	2	30087
7/64	3	30088
7/64	4	30089
1/8	1/8	30100
1/8	1/2	30101
1/8	5/8	30102
1/8	3/4	30103
1/8	1	30104
1/8	1-1/4	30105
1/8	1-1/2	30106
1/8	1-3/4	30107
1/8	2	30108
1/8	2-1/2	30109
1/8	3	30110
1/8	3-1/2	30111
1/8	4	30112
1/8	4-1/2	30113
1/8	5	30114
1/8	6	30115
5/32	5/32	30130
5/32	1/2	30131
5/32	3/4	30132

Size (in) Thkns	Width	UPC No.
5/32	1	30133
5/32	1-1/4	30134
5/32	1-1/2	30135
5/32	1-3/4	30136
3/16	3/16	30150
3/16	1/2	30151
3/16	3/4	30152
3/16	1	30153
3/16	1-1/4	30154
3/16	1-1/2	30155
3/16	1-3/4	30156
3/16	2	30157
3/16	2-1/2	30158
3/16	3	30159
3/16	3-1/2	30160
3/16	4	30161
3/16	5	30162
3/16	6	30163
7/32	7/32	30170
7/32	1/2	30171
7/32	3/4	30172
7/32	1	30173
7/32	1-1/4	30174
7/32	1-1/2	30175
7/32	2	30176
7/32	3	30177
7/32	4	30178
7/32	6	30179
1/4	1/4	30180
1/4	1/2	30181
1/4	3/4	30182
1/4	1	30183
1/4	1-1/4	30184
1/4	1-1/2	30185
1/4	1-3/4	30186
1/4	2	30187
1/4	2-1/2	30188
1/4	3	30189
1/4	3-1/2	30190
1/4	4	30191
1/4	4-1/2	30192
1/4	5	30193
1/4	5-1/2	30194
1/4	6	30195
5/16	5/16	30225
5/16	1/2	30226
5/16	3/4	30227
5/16	1	30228
5/16	1-1/4	30229
5/16	1-1/2	30230
5/16	1-3/4	30231

TEMPERING DATA	
Temper °F	RC
As Quenched	63-65
300	63-65
400	61-64
500	60-63
600	57-60
800	48-51
1000	44-48

Rockwell hardness before heat treatment is RB 88-95

TOLERANCES	
Thickness	±.001
Width	±.005/- .000
Squares	±.001

DRILL ROD

Oil Hardening/Water Hardening Drill Rod

- PRECISION BRAND Drill Rod rounds are made of annealed, ground and polished general purpose tool steel
- Used for punches, tools and dies, drills, taps, arbors, roller bearings, dowel pins and a variety of machine parts where high strength and long life are required
- Excellent finish, strength and machinability makes drill rod ideally suited for power drive shafts and applications where accuracy and straightness are required
- Stocked in 3 feet lengths
- Available in Water Hardening (W-1) and Oil Hardening (0-1) grades
- Other grade and sizes, including metric are available on special order



Water Hardening/W-1

Color coded with RED ends

- Made from a 1095 steel
- Most popular type
- Most versatile and least expensive
- Tough hardening quality affords optimum response to heat treatment and provides toughness and maximum wear resistance in service
- High carbon content allows it to be used without heat treatment for many maintenance applications
- Fine-grained electric furnace melted commercial grade tool steel
- 90% minimum spheroidization, 100% free of decarburization
- Meets ASTM A-686, SAE J-437

TYPICAL C .95 - 1.05, Mn .03 - .40

ANALYSIS: Si .10 - .25, Cr .15 max.,
W .15 max., Mo .10 max
V .10 max., P .025 max.,
S .025 max.

W-1 Heat Treatment

1. Heat thoroughly at 1425 - 1500° F
2. Hold temperature for one-half hour per inch of section
3. Quench in water (brine) (Sizes below 9/32" round may be quenched in oil.)
4. Temper, if desired

Oil Hardening/0-1

Color coded with YELLOW ends

- Made from a 1085 steel
- Electric furnace melt tool steel
- 90% minimum spheroidization
- Non-shrinking general-purpose tool steel
- Highly abrasion resistant
- Excellent toughness and machinability characteristics
- Meets ASTM A-681, SAE J-437

TYPICAL C .85 - .1.00, Mn 1.00 - 1.40

ANALYSIS: Si .50 max., Cr .40 - .70
W .40 - .60, V .30 max.,
P .030 max., S .030 max.

0-1 Heat treatment

1. For section 1/4" and smaller, heat thoroughly to 1450 - 1475° F
2. For sections larger than 1/4", preheat to 1200° F, insert rod, then raise to 1450 - 1500° F
3. Hold temperature for one-half hour per inch of cross section
4. Quench in oil at 125 - 150° F
5. TEMPER IMMEDIATELY

Hardness Before Tempering (Both W-1 & 0-1)		
Decimal Dia.	RB	BHN
.063 - .124	110	341
.125 - .249	104	275
.250 - .875	101	241
.876 - 2.00	96	207

Tensile Strength (Both W-1 & 0-1)	
Decimal Dia.	psi
.063 - .124	170,500
.125 - .249	137,500
.250 - .875	120,500
.876 - 2.00	103,500

Tolerances (Both W-1 & 0-1)	
Decimal Dia.	Tolerances
.063 - .124	±.0003
.125 - .499	±.0005
.500 - 2.00	±.001

W-1 Tempering Data	
Temp. °F	RC
As Quenched	66 - 68
300	64 - 65
400	62 - 64
500	58 - 59
600	54 - 56
700	50 - 51
800	46 - 47

0-1 Tempering Data	
Temp. °F	RC
As Quenched	63 - 65
300	63 - 65
400	61 - 64
500	60 - 63
600	57 - 60
800	48 - 51
1000	44 - 48

- continues -

Precision Brand®

Drill Rod (continued)

3 Feet Lengths					
Size	Diameter		Wt. Per Piece	W-1 Water Hardening UPC No.	O-1 Oil Hardening UPC No.
	Decimal	Metric (mm)			
NO. 52	.063	1.600	.033	18162	28162
NO. 51	.066	1.676	.036	18161	28161
NO. 50	.069	1.753	.039	18160	28160
NO. 49	.072	1.829	.042	18159	28159
NO. 48	.075	1.905	.045	18158	28158
NO. 47	.077	1.956	.048	18157	28157
NO. 46	.079	2.007	.051	18155	28155
NO. 45	.081	2.057	.054	18154	28154
NO. 44	.085	2.159	.057	18153	28153
NO. 43	.088	2.235	.063	18152	28152
NO. 42	.092	2.337	.069	18151	28151
NO. 41	.095	2.413	.072	18149	28149
NO. 40	.097	2.464	.075	18148	28148
NO. 39	.099	2.515	.078	18147	28147
NO. 38	.101	2.565	.084	18146	28146
NO. 37	.103	2.616	.087	18145	28145
NO. 36	.106	2.692	.090	18144	28144
NO. 35	.108	2.743	.093	18143	28143
NO. 34	.110	2.794	.096	18141	28141
NO. 33	.112	2.845	.102	18140	28140
NO. 32	.115	2.921	.108	18139	28139
NO. 31	.120	3.048	.117	18138	28138
NO. 30	.127	3.226	.129	18136	28136
NO. 29	.134	3.404	.144	18135	28135
NO. 28	.139	3.531	.156	18134	28134
NO. 27	.143	3.632	.165	18132	28132
NO. 26	.146	3.708	.171	18131	28131
NO. 25	.148	3.759	.177	18130	28130
NO. 24	.151	3.835	.183	18129	28129
NO. 23	.153	3.886	.189	18128	28128
NO. 22	.155	3.937	.195	18127	28127
NO. 21	.157	3.988	.198	18125	28125
NO. 20	.161	4.089	.207	18124	28124
NO. 19	.164	4.166	.216	18123	28123
NO. 18	.168	4.267	.228	18122	28122
NO. 17	.172	4.369	.237	18120	28120
NO. 16	.175	4.445	.246	18119	28119
NO. 15	.178	4.521	.255	18118	28118
NO. 14	.180	4.572	.261	18117	28117
NO. 13	.182	4.623	.267	18116	28116
NO. 12	.185	4.699	.276	18115	28115
NO. 11	.188	4.775	.282	18113	28113
NO. 10	.191	4.851	.288	18112	28112
NO. 9	.194	4.928	.297	18111	28111
NO. 8	.197	5.004	.312	18110	28110
NO. 7	.199	5.055	.318	18109	28109
NO. 6	.201	5.105	.321	18108	28108
NO. 5	.204	5.182	.327	18106	28106
NO. 4	.207	5.258	.345	18105	28105
NO. 3	.212	5.385	.363	18104	28104
NO. 2	.219	5.563	.387	18102	28102
NO. 1	.227	5.766	.414	18101	28101
A	.234	5.944	.441	18100	28100
B	.238	6.045	.450	18098	28098
C	.242	6.147	.462	18097	28097
D	.246	6.248	.483	18096	28096
E	.250	6.350	.501	18094	28094
F	.257	6.528	.522	18093	28093
G	.261	6.629	.543	18092	28092
H	.266	6.756	.564	18090	28090
I	.272	6.909	.594	18089	28089
J	.277	7.036	.615	18088	28088
K	.281	7.137	.636	18087	28087
L	.290	7.366	.675	18085	28085
M	.295	7.493	.699	18084	28084
N	.302	7.671	.726	18082	28082
O	.316	8.026	.813	18080	28080
P	.323	8.204	.831	18079	28079
Q	.332	8.433	.882	18077	28077
R	.339	8.611	.924	18076	28076
S	.348	8.839	.975	18074	28074
T	.358	9.093	1.026	18073	28073
U	.368	9.347	1.086	18071	28071
V	.377	9.576	1.149	18069	28069
W	.386	9.804	1.200	18068	28068
X	.397	10.084	1.263	18066	28066
Y	.404	10.262	1.281	18065	28065
Z	.413	10.490	1.374	18063	28063
1/16	.0625	1.588	.030	18163	28163
5/64	.0781	1.984	.051	18156	28156
3/32	.0938	2.381	.069	18150	28150

3 Feet Lengths					
Size	Diameter		Wt. Per Piece	W-1 Water Hardening UPC No.	O-1 Oil Hardening UPC No.
	Decimal	Metric (mm)			
7/64	.1094	2.778	.093	18142	28142
1/8	.125	3.175	.126	18137	28137
9/64	.1406	3.572	.156	18133	28133
5/32	.1563	3.969	.198	18126	28126
11/64	.1719	4.366	.234	18121	28121
3/16	.1875	4.763	.282	18114	28114
13/64	.2031	5.159	.327	18107	28107
7/32	.2188	5.556	.387	18103	28103
15/64	.2344	5.953	.441	18099	28099
1/4	.250	6.350	.501	18095	28095
17/64	.2656	6.747	.561	18091	28091
9/32	.2813	7.144	.639	18086	28086
19/64	.2969	7.541	.702	18083	28083
5/16	.3125	7.938	.780	18081	28081
21/64	.3281	8.334	.861	18078	28078
11/32	.3438	8.731	.939	18075	28075
23/64	.3594	9.128	1.032	18072	28072
3/8	.375	9.525	1.125	18070	28070
25/64	.3906	9.922	1.221	18067	28067
13/32	.4063	10.319	1.311	18064	28064
27/64	.4219	10.716	1.416	18062	28062
7/16	.4375	11.113	1.530	18061	28061
29/64	.4531	11.509	1.626	18060	28060
15/32	.4688	11.906	1.749	18059	28059
31/64	.4844	12.303	1.875	18058	28058
1/2	.500	12.700	2.000	18057	28057
33/64	.5156	13.097	2.130	18056	28056
17/32	.5313	13.494	2.250	18055	28055
35/64	.5469	13.891	2.390	18054	28054
9/16	.5625	14.288	2.530	18053	28053
37/64	.5781	14.684	2.670	18052	28052
19/32	.5938	15.081	2.810	18051	28051
39/64	.6094	15.478	3.000	18050	28050
5/8	.625	15.875	3.130	18049	28049
41/64	.6406	16.272	3.310	18048	28048
21/32	.6563	16.669	3.440	18047	28047
43/64	.6719	17.066	3.560	18046	28046
11/16	.6875	17.463	3.750	18045	28045
45/64	.7031	17.859	3.940	18044	28044
23/32	.7188	18.256	4.130	18043	28043
47/64	.7344	18.653	4.310	18042	28042
3/4	.750	19.050	4.500	18041	28041
49/64	.7656	19.447	4.690	18040	28040
25/32	.7813	19.844	4.880	18039	28039
51/64	.7969	20.241	5.120	18038	28038
13/16	.8125	20.638	5.250	18037	28037
53/64	.8281	21.034	5.480	18036	28036
27/32	.8438	21.431	5.690	18035	28035
55/64	.8594	21.828	5.910	18034	28034
7/8	.875	22.225	6.130	18033	28033
57/64	.8906	22.622	6.350	18032	28032
29/32	.9063	23.019	6.560	18031	28031
59/64	.9219	23.416	6.790	18030	28030
15/16	.9375	23.813	7.000	18029	28029
61/64	.9531	24.209	7.250	18028	28028
31/32	.9688	24.606	7.590	18027	28027
63/64	.9844	25.003	7.750	18026	28026
1	1.0000	25.400	8.000	18025	28025
1-1/32	1.0313	26.194	8.500	18024	28024
1-1/16	1.0625	26.988	9.030	18023	28023
1-3/32	1.0938	27.781	9.580	18022	28022
1-1/8	1.125	28.575	10.125	18021	28021
1-5/32	1.1563	29.369	10.700	18020	28020
1-3/16	1.1875	30.163	11.310	18019	28019
1-7/32	1.2188	30.956	11.900	18018	28018
1-1/4	1.250	31.750	12.500	18017	28017
1-9/32	1.2813	32.544	13.120	18016	28016
1-5/16	1.3125	33.338	13.800	18015	28015
1-11/32	1.3438	34.131	14.450	18014	28014
1-3/8	1.375	34.925	15.150	18013	28013
1-13/32	1.4063	35.719	15.820	18012	28012
1-7/16	1.4375	36.513	16.540	18011	28011
1-15/32	1.4688	37.306	17.260	18010	28010
1-1/2	1.500	38.100	18.000	18009	28009
1-9/16	1.5625	39.688	19.560	18008	28008
1-5/8	1.625	41.275	21.150	18007	28007
1-11/16	1.6875	42.863	22.800	18006	28006
1-3/4	1.750	44.450	24.510	18005	28005
1-13/16	1.8125	46.038	26.310	18004	28004
1-7/8	1.875	47.625	28.140	18003	28003
1-15/16	1.9375	49.213	30.060	18002	28002
2	2.0000	50.800	32.040	18001	28001

Maintenance, Repair & Operations

Simple Green®/ Knight's

Simple Green®

**Simple Green®
Concentrated All-Purpose
Cleaner/Degreaser/Deodorizer**

- Biodegradable and non-toxic
- Non-abrasive and non-flammable
- Safer alternative to hazardous chemicals and solvents
- Exempt from OSHA and EPA special handling and personal protection requirements for hazardous materials.

Concentrated, water-based cleaner/degreaser contains blend of synthetic, high-grade penetrants activated by cold/hot water. Custom dilute for specialized cleaning. For use in a broad range of applications including dip tanks. "Clear green" liquid has mild pH of 9.3 to 9.5 and a pleasant sassafras scent. Contains no petroleum distillates. Authorized by USDA for use in Federally inspected meat and poultry plants.

Available in 24-oz. trigger, 1 gallon, 2.5 gallon, 5 gallon, 15 gallon, 55-gallon drum and 275 gallon totes.



**Simple Green® Lime Scale
Remover**

Industrial/Institutional Descaler

- Dissolves soap scum, hard water stains and mineral deposits
- Deodorizes with fresh wintergreen scent
- Non-abrasive and non-flammable
- Contains no bleach, ammonia or phosphorus

Simple Green Lime Scale Remover utilizes a mild buffered acid commonly used in the cosmetic industry. Strong enough to remove hard water deposits but mild enough to protect surfaces from damage that harsher cleaners can cause. Won't strip protective finishes from porcelain, tile or plumbing and will not harm drains or pipes, including PVC.

Available in 32-oz. trigger, 1 gallon, 5 gallon, and 55 gallon drum.



24

Maintenance
Repair
Operations

**Crystal Simple Green®
Industrial Strength Cleaner/Degreaser**

- Non-toxic, non-ionic, and biodegradable
- Economical concentrate
- Non-flammable, non-abrasive, no caustic fumes
- Exempt from OSHA and EPA special handling and personal protection requirements.

Safer, effective and powerful all-purpose cleaner/degreaser for critical cleaning applications that demand a fragrance-free solution. Ideal for industrial/manufacturing, electronics and parts washing industries. Authorized by USDA for use in Federally inspected meat and poultry plants. Meets Montreal Protocol Guidelines and FDA requirements for cleaning in cosmetics, medical and pharmaceutical environments.

Available in 24-oz. trigger, 1 gallon, 5 gallon, 15 gallon, 55-gallon drum, and 275 gallon totes.



**Simple Green® Hand
Cleaner Gel**

Heavy Duty Hand Cleaner

- Simple Green in a gel formula
- Contains pumice for additional scrubbing power
- Contains lanolin to moisturize and protect hands
- Works with or without water

Heavy-duty hand cleaner removes grease, grime, dirt, oil, wet paint, tar, soot, carbon and much more. Non-toxic and non-flammable, Simple Green Hand Cleaner Gel can be used with salt water, fresh water or without any water at all. It has a pleasant sassafras scent. Ideal for industrial, construction, maintenance and commercial applications and comes in several convenient sizes.

Available in 5 oz. tube, 1 gallon with or without pump-top, and 5 gallon.



**Simple Green D®
Disinfectant/Cleaner/Deodorizer**

- One-product disinfectant/cleaner/deodorizer
- Reduces environmental impact
- Non-flammable, non-abrasive
- Versatile and economical

Simple Green D disinfectant provides the strong cleaning power and dependability of original concentrated Simple Green, plus disinfecting capability for those businesses where success depends on providing for the welfare and comfort of others. Safer to use, it reduces the environmental impact posed by other more hazardous disinfectants, cleaners and bleaches. Effective against gram positive and gram negative bacteria & HIV-1 virus.

Available in 32-oz. refill with 16-oz. dilution bottle, 1 gallon, 5 gallon, and 55 gallon drum.



Knight's

Spray Nine®

Spray Nine®, America's first multi-purpose, hard surface, "spray on - wipe off", germicidal cleaner.

Kills HIV-1 (Associated with AIDS), Salmonella, Staphylococci and Pseudomonas in just 30 seconds and packs BIG POWER to tackle a wide range of difficult soils... yet it contains no bleach, acids, chlorinated or petroleum solvents, and is nonflammable, ready-to-use, and harmless to almost all hard surfaces. Spray Nine® - when you need the best!

Soils:

- | | | |
|--------------------|----------------|---------------------|
| Smoke Deposits | Light Rust | Pencil & Ink |
| Soot | Lipstick | Cooking Stains |
| Lube Oil | Old Wax | Burned Food |
| Grease | Bathtub Ring | Crayon |
| Fingerprints | Algae & Mildew | Inorganic Soils |
| Fresh Paint | Road Film | Silt |
| Heel & Scuff Marks | Gum | Perspiration Stains |

Surfaces:

- | | | |
|-----------------|-------------------|---------------------------|
| Plastic | Walls & Ceilings | Car Interiors |
| Vinyl | Sinks & Tubs | Carpeting (except wool) |
| Rubber | Toilets | Oil Base Painted Surfaces |
| Stainless Steel | Pools | Plaster & Enamel |
| Chrome | Outdoor Furniture | Trailers |
| Tools | Toys | Synthetic Fabrics |
| Floors | Car Mats | Fiberglass Boats |



Stock No.	Unit	Package	Gross Wt. (lbs)
26824	24 oz.	12/case	22
26825	25 oz.	12/case	24
26832	32 oz.	12/case	30
26802	2 L.	6/case	30
26801	1 gal.	6/case	55
26805	5 gal.	pail	46
26815	15 gal.	drum	144
26830	30 gal.	drum	277
26855	55 gal.	drum	510

Touch 'n Seal/United Tape Co.

Touch 'n Seal

QUICK CURING FOAM SEALANT

Touch 'n Seal Patented All-Direction Dispensing System lets you spray foam at any angle... In any direction. Unlike most other spray foams, now you have unlimited application range. makes jobs easier and quicker to do.

Before use, shake can well and dispense in upright position. Do Not Shake Again UNLESS can remains unused for 45 minutes or more.



12 oz.

GUN SYSTEMS/GUN APPLICATORS/
ALL-DIRECTION DISPENSING/
2-COMPONENT SYSTEMS/CYLINDER SYSTEMS/
POLY-CLEAN II/TECHNICAL SPECS
1-COMPONENT I TECHNICAL SPECS
2-COMPONENT/HOME I DO-IT-YOURSELFERS

United Tape Co.

DUCT TAPES

UT-357 Superior Grade Duct Tape

Our strongest heavy duty, waterproof duct tape. This 13-mil product is ideal for the most demanding of industrial applications.



SKU#	Size (in x yds)	Case Qty.	Case Wt. (lbs)
UT-357 2	2" x 60 yds.	24	60.00

UT-110 Superior Grade Duct Tape

Another heavy-duty waterproof duct tape. A 12 mil product that also provides excellent strength and durability.



24 oz.

SKU#	Size (in x yds)	Case Qty.	Case Wt. (lbs)
UT-110 2	2" x 60 yds.	24	47.04
UT-110 3	3" x 60 yds.	16	47.04

UT-109 Premium Grade Duct Tape

An 11-mil waterproof duct tape that performs well in a variety of applications including duct work and asbestos abatement.



SKU#	Size (in x yds)	Case Qty.	Case Wt. (lbs)
UT-109 2	2" x 60 yds.	24	42.24

UT-102 Contractor Grade Duct Tape

Polyethylene coated cloth, 10 mil, and waterproof duct tape. Excellent for insulation, asbestos abatement, duct systems, and most professional applications.



SKU#	Size (in x yds)	Case Qty.	Case Wt. (lbs)
UT-102 2	2" x 60 yds.	24	40.40
UT-102 3	3" x 60 yds.	16	40.40

UT-20C Colored Duct Tape

Polyethylene coated cloth, available in 6 colors. Used for holding down indoor and outdoor carpet, color coding and vinyl repair.



SKU#	Size (in x yds)	Case Qty.	Case Wt. (lbs)
UT-20C-BL 2	2" x 60 yds.	24	40.00
UT-20C-BR 2	2" x 60 yds.	24	40.00
UT-20C-GR 2	2" x 60 yds.	24	40.00
UT-20C-WT 2	2" x 60 yds.	24	40.00
UT-20C-YL 2	2" x 60 yds.	24	40.00
UT-20C-OR 2	2" x 60 yds.	24	40.00

Also available in custom widths.

UT-1022 Standard Grade Duct Tape

Our most popular and versatile duct tape. Polyethylene coated cloth, suitable for contractors and Do It Yourself applications



SKU#	Size (in x yds)	Case Qty.	Case Wt. (lbs)
UT-1022 2	2" x 60 yds.	24	40.22
UT-1022 3	3" x 60 yds.	16	40.22

FOIL TAPES

UT-41 Contractor Grade Foil Tape

A 2-mil aluminum foil with an acrylic adhesive and easy release liner. Used on air conditioning duct systems. U.L., and HUD approved.



SKU#	Size (in x yds)	Case Qty.	Case Wt. (lbs)
UT-41 2	2" x 50 yds.	24	31.00
UT-41 2-1/2	2-1/2" x 50 yds.	20	34.00
UT-41 3	3" x 50 yds.	16	30.00
UT-41 4	4" x 50 yds.	12	30.00

UT-43 FSK Foil Tape

A 5 mil, tri-directional Foil Scrim Kraft (FSK) Facestock. Specially designed for taping insulation joints against moisture and vapor on tri-directional FSK jacketing.



SKU#	Size (in x yds)	Case Qty.	Case Wt. (lbs)
UT-43 2	2" x 50 yds.	20	36.00
UT-43 3	3" x 50 yds.	16	34.00

UT-45 Code Approved Foil Tape

Printed foil tape that meets U.L. 181 and SMACNA AFTS 101-73 performance standards. Used to tape and seal joints and seams on fibrous duct boards.



SKU#	Size (in x yds)	Case Qty.	Case Wt. (lbs)
UT-45 2-1/2	2-1/2" x 60 yds.	16	49.00

Maintenance, Repair & Operations

United Tape Co.

PACKAGING TAPES

UT-33 Strapping Tape

High tensile, polyester backed fiberglass tape used where extra strength is needed for palletizing and bundling.



SKU#	Size (mm x m)	Case Qty.	Case Wt. (lbs)
UT-33 1/2	9mm x 54.86m	72	19.00
UT-33 3/4	18mm x 54.86m	48	19.00
UT-33 1	24mm x 54.86m	36	18.00
UT-33 2	48mm x 54.86m	24	19.00

PSWF Wrapping Film

80-gauge stretch film on a throwaway hand dispenser.



SKU#	Size (in x ft)	Case Qty.	Case Wt. (lbs)
UT-PSWF	5" x 1000 ft.	15	30.00

UT-4040C Heavy Duty Packaging Tape

Biaxially oriented polypropylene heavy-duty box and bag sealing tape. (2.2 mil.) Available in clear only. Acrylic.



SKU#	Size (in x yds)	Case Qty.	Case Wt. (lbs)
UT-4040C	1.89" x 54.68 yds.	36	13.00

UT-PVC Packaging Tape

Unplasticized PVC normally used in strength necessitated applications. Available in tan and clear. Acrylic.



SKU#	Size (in x yds)	Case Qty.	Case Wt. (lbs)
UT-PVC-C	2" x 55 yds.	36	14.00
UT-PVC-T	2" x 55 yds.	36	14.00

Stretch Film

High cling film with excellent stretch and holding properties suitable for most all general purpose palletizing. This 80-gauge, stretch film is available in 12", 15", and 18" widths, on a 3" dispenser core.



SKU#	Size (in x ft)	Case Qty.	Case Wt. (lbs)
SF3801215C	12" x 1500 ft.	4	23.00
SF3801515C	15" x 1500 ft.	4	29.00
SF3801815C	18" x 1500 ft.	4	34.00
SF3802005M	20" x 5000 ft.	1	32.00 ea.
SF DIS 018	Dispenser	1	4.00

Dispensers

UT500 Strapping tape dispenser accommodates up to 1" widths. Normally used with UT-22 or UT-33. UT501, UT503 Carton sealing tape dispensers for 3" core, 2" width film tapes. Each features adjustable tension spool. (UT-501) General Purpose, (UT-503) Heavy Duty.



SKU#	Size	Case Qty.	Case Wt. (lbs)
UT-500	Up to 2" roll	20	13.00
UT-501	Up to 3" roll	24	25.00
UT-503	Up to 3" roll	24	30.00

ELECTRICAL TAPES

Imported Electrical Tapes

UT460 Premium grade vinyl electrical tape, 8.5 mil, U.L. approved, flame retardant, cold weather resistant. UT602 and UT302 U.L. approved 7-mil vinyl electrical tape.



SKU#	Size (in x ft)	Case Qty.	Case Wt. (lbs)
UT-460	3/4" x 66 ft.	10/200	44.00
UT-602	3/4" x 60 ft.	10/200	34.00
UT-302	3/4" x 30 ft.	10/500	47.00

Colored Electrical Tapes

A 7 mil colored vinyl tape. U.L. approved. Used primarily for color coding electrical wiring. 8 colors. (Import)



SKU#	Size (in x ft)	Case Qty.	Case Wt. (lbs)
UT-34-BL 66	3/4" x 66 ft.	10/200	39.00
UT-34-BR 66	3/4" x 66 ft.	10/200	39.00
UT-34-GR 66	3/4" x 66 ft.	10/200	39.00
UT-34-GY 66	3/4" x 66 ft.	10/200	39.00
UT-34-OR 66	3/4" x 66 ft.	10/200	39.00
UT-34-RD 66	3/4" x 66 ft.	10/200	39.00
UT-34-WT 66	3/4" x 66 ft.	10/200	39.00
UT-34-YL 66	3/4" x 66 ft.	10/200	39.00
UT-34ACP	3/4" x 12 ft. 5-pk	12/120	60.00

Insulating Tapes

UT-15 Black cloth friction tape. 1,000 volts minimum dielectric strength. Used for overwrapping low voltage splices. UT-13, 30 mil of semi-cured rubber for low voltage electrical insulation. Self-vulcanizing and water-resistant.



SKU#	Size (in x ft)	Case Qty.	Case Wt. (lbs)
UT-15-60	3/4" x 60 ft.	100	38.00
UT-15-30	3/4" x 30 ft.	200	26.00
UT-13	3/4" x 22 ft.	100	34.00
UT-13-2	2" x 22 ft.	36	32.00

DOUBLE FACE TAPES

UT-16 Double Face Foam Tape

Double coated polyolefin foam with acrylic adhesive on both sides. Used for permanent bonding to metal, glass, and other smooth surfaces where watertight and airtight bond is required. 1/16" thick for heavy-duty applications.



SKU#	Size (in x in x yds)	Case Qty.	Case Wt. (lbs)
UT-16-1/4	1/4" x 1/16" x 36 yds	48	9.00
UT-16-1/2	1/2" x 1/16" x 36 yds	24	8.00
UT-16-3/4	3/4" x 1/16" x 36 yds	16	11.00
UT-16-1	1" x 1/16" x 36 yds	12	9.00
UT-16-1-1/2	1-1/2" x 1/16" x 36 yds	8	10.00
UT-16-2	2" x 1/16" x 36 yds	6	7.00

UT-730 Double Face Paper Tape

A durable paper tape with high tack for plate mounting, splicing, lamination and other industrial applications.



SKU#	Size (in x yds)	Case Qty.	Case Wt. (lbs)
UT-730-1/2	1/2" x 36 yds	72	14.00
UT-730-3/4	3/4" x 36 yds	48	15.00
UT-730-1	1" x 36 yds	36	14.00
UT-730-1-1/2	1-1/2" x 36 yds	24	15.00
UT-730-2	2" x 36 yds	24	25.00
UT-730-3	3" x 36 yds	12	15.00

United Tape Co./ZRC Worldwide

MASKING TAPES

UT-55 Painter's/Premium Grade

Painter's or industrial grade masking tape with excellent tack. Suitable for all general painting applications.

SKU#	Size (in x yds)	Case Qty.	Case Wt. (lbs)
*UT-55 1/2	1/2" x 60 yds	72	14.00
UT-55 3/4	3/4" x 60 yds	48	14.00
UT-55 1	1" x 60 yds	36	14.00
UT-55 1-1/2	1-1/2" x 60 yds	24	14.00
UT-55 2	2" x 60 yds	24	16.00
UT-55 3	3" x 60 yds	12	14.00

*Bulk Only



UT-77 Standard Grade

All-purpose, standard grade masking tape with excellent properties for most masking applications.

SKU#	Size (in x yds)	Case Qty.	Case Wt. (lbs)
UT-77 1/2	1/2" x 60 yds	72	13.00
UT-77 3/4	3/4" x 60 yds	48	13.00
UT-77 1	1" x 60 yds	36	13.00
UT-77 1-1/2	1-1/2" x 60 yds	24	13.00
UT-77 2	2" x 60 yds	24	15.00
UT-77 3	3" x 60 yds	12	13.00
*UT-77 4	4" x 60 yds	12	17.00
*UT-77 6	6" x 60 yds	8	16.00

*Non-standard



SPECIALTY TAPES

UT-11 Teflon Tape

Teflon thread sealing tape. Chemically inert, withstands alkalis, acids, oils, and solvents. Can be used on iron, stainless steel, copper, brass, plastic, glass or rubber pipes. *Teflon is a registered trademark of DuPont.

SKU#	Size (in x in)	Case Qty.	Case Wt. (lbs)
UT-11 1/2 x 260	1/2" x 260"	200	3.00
UT-11 1/2 x 520	1/2" x 520"	200	4.00
UT-11 3/4 x 260	3/4" x 260"	144	5.00
UT-11 3/4 x 520	3/4" x 520"	144	6.00
UT-11 1 x 260	1" x 260"	144	7.00
UT-11 1 x 520	1" x 520"	144	7.00



ZRC Worldwide

Galvanizing Compounds

ZRC Galvilité Galvanizing Compound

Specifications: Silvery-finish Galvanic Zinc-Rich coating containing 95% metallic zinc, by weight in the dried film; recognized under the Component Program of Underwriter's Laboratories, Inc. as an equivalent to hot-dip galvanizing; conforming to Federal Specification DOD-P21035A (formally MIL-P-21035A) for repair of hot-dip galvanizing and meeting the requirements of Military Specification MIL-P26915A USAF Specification for Zinc-Rich Paints; as manufactured by ZRC Products Company, Quincy, MA or other facility having been registered to the International Organization for Standardization ISO 9001 standard for quality; or approved equal.

Type: Single pack, premixed, ready-to-apply, liquid organic zinc compound with a shiny finish to closely approximate the color of hot-dip galvanizing.

General Properties: Galvilité® is a high-quality metallic zinc coating based on a trade secret organic binder which affords true galvanic anti-corrosion protection to metals. The dried film of GALVILITE is 95% metallic zinc. Because of the uniqueness of the formulation, GALVILITE is the only coating of its type to be recognized under the Component Program of Underwriter's Laboratories, Inc.

- continues -

ZRC Galvilité Galvanizing Compound (continued)

Recommended Uses: Galvilité is widely used without topcoat in place of hot-dip galvanizing. Also used as a high-performance base coat with a variety of topcoats. Used for repair of damaged hot-dip galvanizing Galvalume® and zinc metallizing, regalvanizing worn hot-dip galvanizing, repair of weldments, and repair of damaged inorganic zinc coatings. Excellent for long-term protection of structural steel, water and waste facilities, power plants, transmission towers and antennae, steel decking and bridges and numerous OEM uses.

Substrates: Apply to properly prepared carbon steel, cast iron, hot-dip galvanized, and aluminum surfaces.

Not Recommended For: Contact with potable water, strong acids or strong alkalis

Temperature Resistance (non-immersion):

- Continuous: 350 degrees F max
- Non-Continuous: 750 degrees F max

Salt Fog Exposure: 2,852 Hours (ASTM B117)

Prohesion/QUV Exposure:
2,000 Hours (ASTM D5894)

VOC: 3.3 lbs/gal (ASTM D3960)

Part No.	Size	Wt./ Unit (lbs)	Unit/ Case
20014	3.5 gallon pails	90	1
20013	1-gallon can	25	2
20012	quart can	6	6
20011	1/2 pint can	1.5	24
20010	12 oz. Aerosol can	1	24



ZRC Cold Galvanizing Compound

Specifications: Organic Zinc-Rich coating containing 95% metallic zinc, by weight in the dried film; recognized under the Component Program of Underwriter's Laboratories, Inc. as an equivalent to hot-dip galvanizing; conforming to Federal Specification DODP-21035A (formally MIL-P-21035A) for repair of hot-dip galvanizing and meeting the requirements of Military Specification MIL-P-26915A USAF Specification for Zinc-Rich Paints; as manufactured by ZRC Products Company, Quincy, MA or other facility having been registered to the International Organization for Standardization ISO 9001 standard for quality; or approved equal.

Type: Single pack, premixed, ready-to-apply, liquid organic zinc compound

General Properties: ZRC® is a high-quality metallic zinc coating based on a trade secret organic binder which affords true galvanic anti-corrosion protection to metals. The dried film of ZRC is 95% metallic zinc. Because of the uniqueness of the formulation, ZRC is the only coating of its type to be recognized under the Component Program of Underwriter's Laboratories, Inc.

Recommended Uses: ZRC is widely used without topcoat in place of hot-dip galvanizing. Also used as a high-performance base coat with a variety of topcoats. Used for repair of damaged hot-dip galvanizing Galvalume® and zinc metallizing, regalvanizing worn hot-dip galvanizing, repair of weldments, and repair of damaged inorganic zinc coatings. Excellent for long-term protection of structural steel, water and waste facilities, power plants, transmission towers and antennae, steel decking and bridges and numerous OEM uses.

Substrates: Apply to properly prepared carbon steel, cast iron, hot-dip galvanized, and aluminum surfaces.

Not Recommended For: Contact with potable water, strong acids or strong alkalis

Temperature Resistance (non-immersion):

- Continuous: 350 degrees F max
- Non-Continuous: 750 degrees F max

Salt Fog Exposure: 2,852 Hours (ASTM B117)

Prohesion/QUV Exposure: 2,000 Hours (ASTM D5894)

VOC: 3.3 Lbs/gal (ASTM D3960)

Part No.	Size	Wt./ Unit (lbs)	Unit/ Case
10004	3.5 gallon pails	90	1
10003	1-gallon can	25	2
10002	quart can	6	6
10001	1/2 pint can	1.5	24
10000	12 oz. Aerosol can	1	24



24
Maintenance
Repair
Operations

