

SECTION 4

Rigging Fittings

BARREL HOOKS	4-21	GATE HOOKS		HOOKS, LOGGING	
BOLT		Closed Swivel Bail	4-25	Bardon® Choker	4-27
Eye Lifting	4-39-43, 4-48	Customized	4-26-27	Chain Winchline	4-27
CABLE CLAMPS		Dimension Chart	4-26	Chainrite® Choker	4-27
Continuous	4-2	Identification and Load Limit Chart	4-24	Double-Ender	4-27
CHAIN CONNECTOR		Link Chain Nest	4-25	Ring-Type Holdrite®	4-27
Link, Stainless Steel	4-46	Open Swivel Bail	4-25	Screwy® Guy Line	4-27
Shackle Sling Saver®	4-9-11	Roller Chain Nest	4-25	Sleeve-Type Holdrite®	4-27
CHAIN HOOKS		Safety and Application Instructions	4-24	Sliding Winchline	4-27
Clevis Grab	4-28, 4-48	Shank Hook	4-25	HOOKS, STAINLESS STEEL	
Clevis Slip	4-28, 4-48	HAMMERLOCK – STAINLESS STEEL	4-46	Clevis Grab	4-40
Eye Grab	4-28, 4-48	HITCH PINS	4-44	Clevis Slip	4-40
Eye Slip	4-12, 4-28, 4-49	HOIST RINGS		Eye Grab	4-40
CHOKER		Applications	4-33	Eye Hook	4-49
Hooks	4-11, 4-19, 4-21, 4-27	Forged (Pivoting, Non-Rotating)	4-33	Eye Slip	4-49
CLAMPS, CABLE		Heavy Lift	4-35	Swivel Eye	4-49
Continuous	4-2	Inspection/Maintenance	4-33	HOT FORMED PRODUCTS	4-32
CLEVISES		Large Opening	4-37	LATCH KITS	4-22-23
Adjustable Yoke Ends	4-31	Metric	4-34-38	LINKS, LIFTING	
Clevis Pins	4-31, 4-44	Rectangular Plate	4-38	Connecting Links – Stainless Steel	4-46
Drop-Forged	4-32	Round Base	4-38	Hammerlock – Stainless Steel	4-46
Farm Hardware	4-49	Side Load	4-36	Master Link	4-11, 4-46
General Purpose	4-49	Side Pull	4-38	Pear-Shaped	4-12
Plain Yoke Ends	4-31	Speed Base	4-39	Weldless	4-12
Utility	4-49	Stainless Steel	4-37	LOGGING HOOKS	4-27
CLIPS, WIRE ROPE		Swivel and Pivoting	4-37-38	MASTER LINK	
First Grip® Clips	4-2	UNC Threads	4-34-38	Alloy	4-11
Forged Wire Rope Clip	4-1	HOIST SHANK HOOKS	4-12, 4-20, 4-25	Stainless Steel	4-46
How to Install Wire Rope Clips	4-1	HOOKS, LIFTING		NUTS	
Malleable	4-2	Alloy	4-13-21, 4-28	Coupling Nut	4-44
Stainless Steel	4-1, 4-45	Alloy Eye	4-29	Lifting Eye	4-35, 4-40
CONNECTORS, CHAIN		Alloy Hook Latch Kit	4-22	Recessed Nut and Pin	4-44
Link, Stainless Steel	4-46	Alloy Swivel Eye	4-28-29	Sleeve	4-44
Shackle Sling Saver®	4-9-11	Barrel	4-21	PELICAN HOOK	4-21
COUPLING NUT	4-44	Choker	4-11, 4-19, 4-21, 4-27	PINS, HITCH	4-44
EYE BOLTS, LIFTING		Closed Swivel Bail	4-25	PIPE HOOK	4-22
Alloy	4-41	Gate Hooks	4-24-27	PLATE, LIFTING	
Alloy Reduced	4-41	Grab, Clevis	4-28, 4-48	Pivoting	4-38
Applications and Installation	4-39-40	Grab, Eye	4-28, 4-48	RIGGING CONNECTORS	
Machine	4-39-42	Hoist Shank	4-12, 4-20	Link, Stainless Steel	4-46
Metric Lifting	4-41	Link Chain Nest	4-25	Shackle Sling Saver®	4-9-11
Plain Pattern	4-41	Open Swivel Bail	4-25	RING, LIFTING	
Reduced Eyes	4-41	Pelican Hook	4-21	Alloy	4-11-12
Regular Nut	4-39-40	Pipe Hook	4-22	Street Plate Lifting Ring	4-39
Rivet	4-42	Release-A-Matic	4-22	Weldless	4-12
Screw	4-40	Roller Chain Nest	4-25	SHACKLES	
Shoulder Nut	4-39-40, 4-42-43, 4-48	Safety Latch Kits	4-22-23	Alloy "Wide Body"	4-7
Shoulder Rivet	4-42	Shank Hooks	4-12, 4-20, 4-25	Alloy Bolt Type	4-7
Shoulder Type Machinery	4-42	Shipyards	4-49	Anchor	4-4-5, 4-47
Stainless	4-42-43, 4-48	Sliding Hooks	4-21	Bolt Type	4-7, 4-46
EYE NUT, LIFTING		Slip, Clevis	4-28, 4-48	Bow, Stainless Steel	4-47
Forged	4-43	Slip, Eye	4-28, 4-49	Chain	4-6, 4-46
Stainless	4-48	Snap Hooks	4-21	Euro Ground Release Shackle	4-8
EYES, LIFTING		Sorting Hook	4-21	Long Reach	4-4, 4-46, 4-47
Lifting	4-43	Stainless Steel Hooks	4-48-49	Sheet Pile	4-8
Nut Eyes	4-43, 4-48	Swivel Hooks	4-14-16, 4-25, 4-28, 4-49	Stainless Steel	4-5, 4-46-47
Pad	4-43	Web Sling Hook	4-13	Synthetic Sling Saver Shackle	4-9
		Weld On	4-28	Web Sling Shackle	4-9

– continues –

Clips

How to Install Wire Rope Clips

! WARNING !

- Failure to read, understand, and follow these instructions may cause death or serious injury.
- Read and understand these instructions before using clips.
- Match the same size clip to the same size wire rope.
- Prepare wire rope end termination only as instructed.
- Do not use with plastic coated wire rope.
- Apply first load to test the assembly. This load should be of equal or greater weight than loads expected in use. Next, check and retighten nuts to recommended torque (See Table 1, this page).

Efficiency ratings for wire rope end terminations are based upon the catalog breaking strength of wire rope. The efficiency rating of a properly prepared loop or thimble - eye termination for clip sizes 1/8" through 7/8" is 80%, and for sizes 1" through 3-1/2" is 90%.

The number of clips shown (see Table 1) is based upon using RRL or RLL wire rope, 6 x 19 or 6 x 37 Class, FC or IWRC; IPS or XIP. If Seale construction or similar large outer wire type construction in the 6 x 19 Class is to be used for sizes 1 inch and larger, add one additional clip. If a pulley (sheave) is used for turning back the wire rope, add one additional clip.

The number of clips shown also applies to rotation resistant RRL wire rope, 8 x 19 Class, IPS, XIP, sizes 1-1/2 inch and smaller; and to rotation-resistant RRL wire rope, 19 x 7 Class, IPS, XIP, sizes 1-3/4 inch and smaller.

For other classes of wire rope not mentioned above, we recommend contacting one of our representatives to ensure the desired efficiency rating.

For elevator, personnel hoist, and scaffold applications, refer to ANSI A17.1 and ANSI A10.4. These standards do not recommend U-Bolt style wire rope clip terminations. The style wire rope termination used for any application is the obligation of the user.

For OSHA (Construction) applications, see OSHA 1926.251.

1) Refer to Table 1 in following these instructions. Turn back specified amount of rope from thimble or loop. Apply first clip one base width from dead end of rope. Apply U-Bolt over dead end of wire rope - live end rests in saddle (Never saddle a dead horse!). Tighten nuts evenly, alternate from one nut to the other until reaching the recommended torque.

2) When two clips are required, apply the second clip as near the loop or thimble as possible. Tighten nuts evenly, alternating until reaching the recommended torque. When more than two clips are required, apply the second clip as near the loop or thimble as possible, turn nuts on second clip firmly, but do not tighten. Proceed to Step 3.

3) When three or more clips are required, space additional clips equally between first two - take up rope slack - tighten nuts on each U-Bolt evenly, alternating from one nut to the other until reaching recommended torque.

4) WIRE ROPE SPLICING PROCEDURES:

The preferred method of splicing two wire ropes together is to use interlocking turnback eyes with thimbles, using the recommended number of clips on each eye (See Figure 1).

An alternate method is to use twice the number of clips as used for a turnback termination. The rope ends are placed parallel to each other, overlapping by twice the turnback amount shown in the application instructions. The minimum number of clips should be installed on each dead end (See Figure 2). Spacing, installation torque, and other instructions still apply.

5) IMPORTANT: Apply first load to test the assembly. This load should be of equal or greater weight than loads expected in use. Next, check and retighten nuts to recommended torque.

In accordance with good rigging and maintenance practices, the wire rope end termination should be inspected periodically for wear, abuse, and general adequacy.

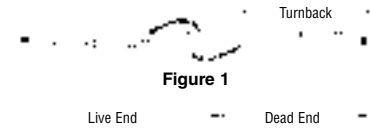

Figure 1

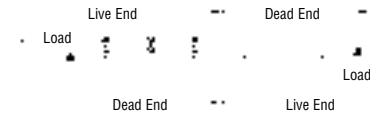

Figure 2

Clip Size (in)	Rope Size (in)	Min. No. of Clips	Amt. of Rope to Turn Back (in)	* Torque (ft/ lbs)
1/8	1/8	2	3-1/4	4.5
3/16	3/16	2	3-3/4	7.5
1/4	1/4	2	4-3/4	15
5/16	5/16	2	5-1/4	30
3/8	3/8	2	6-1/2	45
7/16	7/16	2	7	65
1/2	1/2	3	11-1/2	65
9/16	9/16	3	12	95
5/8	5/8	3	12	95
3/4	3/4	4	18	130
7/8	7/8	4	19	225
1	1	5	26	225
1-1/8	1-1/8	6	34	225
1-1/4	1-1/4	7	44	360
1-3/8	1-3/8	7	44	360
1-1/2	1-1/2	8	54	360
1-5/8	1-5/8	8	58	430
1-3/4	1-3/4	8	61	590
2	2	8	71	750
2-1/4	2-1/4	8	73	750
2-1/2	2-1/2	9	84	750
2-3/4	2-3/4	10	100	750
3	3	10	106	1200
3-1/2	3-1/2	12	149	1200

If a pulley (sheave) is used for turning back the wire rope, add one additional clip.

If a greater number of clips are used than shown in the table, the amount of turnback should be increased proportionately.

*The tightening torque values shown are based upon the threads being clean, dry, and free of lubrication.

Forged Wire Rope Clips Crosby® G-450

- Each base has a Product Identification Code (PIC) for material traceability, the name CROSBY or "CG", and a size forged into it.
 - Sizes 1/8" through 2-1/2" have forged bases.
 - Entire Clip - Galvanized to resist corrosive and rusting action.
 - Only Genuine Crosby Clips have a Red U-BOLT for instant recognition.
 - All Clips are individually bagged or tagged with proper application instructions and warning information.
 - Clip sizes up through 1-1/2" have rolled threads.
- Crosby Clips, all sizes 1/4" and larger, meet the performance requirements of Federal Specification FF-C-450 TYPE 1 CLASS 1, except for those provisions



G-450

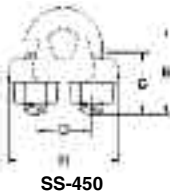

SS-450

"316" Stainless Steel Wire Rope Clips - Crosby® SS-450

- Each base has a Product Identification Code (PIC) for material traceability, the name CROSBY or CG, and a size forged into it.
- Available in sizes 1/8 through 5/8".
- Entire clip is made from 316 Stainless Steel to resist corrosive and rusting action.
- All components are Electro - Polished.
- All Clips are individually bagged or tagged with proper application instructions and warning information.

Rope Size (in)	G-450 Stock No.	Std. Pkg. Qty.	Wt. Per 100 (lbs)	Dimensions (in)							
				A	B	C	D	E	F	G	H
*1/8	1010015	100	6	.22	.72	.44	.47	.41	.38	.81	.94
*3/16	1010033	100	10	.25	.97	.56	.59	.50	.44	.94	1.16
1/4	1010051	100	19	.31	1.03	.50	.75	.66	.56	1.19	1.44
5/16	1010079	100	28	.38	1.38	.75	.88	.72	.69	1.31	1.69
3/8	1010097	100	48	.44	1.50	.75	1.00	.91	.75	1.63	1.94
7/16	1010113	50	78	.50	1.88	1.00	1.19	1.03	.88	1.81	2.28
1/2	1010131	50	80	.50	1.88	1.00	1.19	1.13	.88	1.91	2.28
9/16	1010159	50	109	.56	2.25	1.25	1.31	1.22	.94	2.06	2.50
5/8	1010177	50	110	.56	2.38	1.25	1.31	1.34	.94	2.06	2.50
3/4	1010195	25	142	.62	2.75	1.44	1.50	1.41	1.06	2.25	2.84
7/8	1010211	25	212	.75	3.12	1.62	1.75	1.59	1.25	2.44	3.16
1	1010239	10	252	.75	3.50	1.81	1.88	1.78	1.25	2.63	3.47
1-1/8	1010257	10	283	.75	3.88	2.00	2.00	1.91	1.25	2.81	3.59
1-1/4	1010275	10	438	.88	4.25	2.13	2.31	2.19	1.44	3.13	4.13
1-3/8	1010293	10	442	.88	4.63	2.31	2.38	2.31	1.44	3.13	4.19
1-1/2	1010319	10	544	.88	4.94	2.38	2.59	2.44	1.44	3.41	4.44
1-5/8	1010337	Bulk	704	1.00	5.31	2.62	2.75	2.66	1.63	3.63	4.75
1-3/4	1010355	Bulk	934	1.13	5.75	2.75	3.06	2.94	1.81	3.81	5.28
2	1010373	Bulk	1300	1.25	6.44	3.00	3.38	3.28	2.00	4.44	5.88
2-1/4	1010391	Bulk	1600	1.25	7.13	3.19	3.88	3.19	2.00	4.50	6.38
2-1/2	1010417	Bulk	1900	1.25	7.69	3.44	4.13	3.69	2.00	4.05	6.63
†2-3/4	1010435	Bulk	2300	1.25	8.31	3.56	4.38	4.88	2.00	5.00	6.88
3	1010453	Bulk	3100	1.50	9.19	3.88	4.75	4.69	2.38	5.88	7.63
†3-1/2	1010426	Bulk	4000	1.50	10.75	4.50	5.50	6.00	2.38	6.19	8.38

* Electro-plated U-Bolt and Nuts

† 2-3/4" and 3-1/2" base is made of cast steel

Rope Size (in)	SS-450 Stock No.	Wt. Per 100 (lbs)	Dimension (in)							
			A	B	C	D	E	F	G	H
1/8	1011250	6	.22	.72	.44	.47	.41	.38	.81	.94
3/16	1011261	10	.25	.97	.56	.59	.50	.44	.94	1.16
1/4	1011272	20	.31	1.03	.50	.75	.66	.56	1.19	1.44
3/8	1011283	47	.44	1.50	.75	1.00	.91	.75	1.63	1.94
1/2	1011305	77	.50	1.88	1.00	1.19	1.13	.88	1.91	2.28
5/8	1011327	106	.56	2.38	1.25	1.31	1.34	.94	2.06	2.50

Rigging Fittings

Clips/Clamps/Thimbles

Fist Grip® Forged Wire Rope Clips

Crosby® G-429

- Bolts are an integral part of the saddle. Nuts can be installed in such a way as to enable the operator to swing the wrench in a full arc for fast installation.
- All sizes have forged steel saddles.
- Entire clip is Galvanized to resist corrosive and rusting action.
- All Clips are individually bagged or tagged with proper application instructions and warning information.

Clip Size (in)	Rope Size (in)	Min. No. of Clips	Amt. of Rope to Turn Back (in)	*Torque (ft/lbs)
3/16	3/16	2	4	30
1/4	1/4	2	4	30
5/16	5/16	2	5	30
3/8	3/8	2	5-1/4	45
7/16	7/16	2	6-1/2	65
1/2	1/2	3	11	65
9/16	9/16	3	12-3/4	130
5/8	5/8	3	13-1/2	130
3/4	3/4	3	16	225
7/8	7/8	4	26	225
1	1	5	37	225
1-1/8	1-1/8	5	41	360
1-1/4	1-1/4	6	55	360
1-3/8	1-3/8	6	62	500
1-1/2	1-1/2	7	78	500

If a pulley (sheave) is used for turning back the wire rope, add one additional clip.

If a greater number of clips are used than shown in the table, the amount of turnback should be increased proportionately.

*The tightening torque values shown are based upon the threads being clean, dry, and free of lubrication.

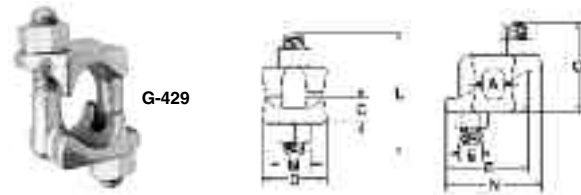

Rope Size (in)	G-429 Stock No. Galv.	Std. Pkg. Qty.	Wt. Per 100 (lbs)	Dimensions (in)								
				A	B	C	D	E	G	L	M	N
3/16 - 1/4	1010471	100	23	.25	1.25	.34	.94	.38	1.28	1.63	.69	1.47
5/16	1010499	100	28	.31	1.34	.44	1.06	.38	1.47	1.94	.69	1.56
3/8	1010514	50	40	.38	1.59	.50	1.06	.44	1.81	2.38	.75	1.88
7/16 - 1/2	1010532	50	62	.50	1.88	.56	1.25	.50	2.19	2.75	.88	2.19
9/16 - 5/8	1010550	50	103	.63	2.28	.69	1.50	.63	2.69	3.50	1.06	2.63
3/4	1010578	25	175	.75	2.69	.88	1.81	.75	2.94	3.75	1.25	3.06
7/8	1010596	25	225	.88	2.97	.97	2.13	.75	3.31	4.13	1.25	3.14
1	1010612	10	300	1.00	3.06	1.19	2.25	.75	3.72	4.63	1.25	3.53
1-1/8	1010630	10	400	1.13	3.44	1.28	2.38	.88	4.19	5.25	1.44	3.91
1-1/4	1010658	10	400	1.25	3.56	1.34	2.50	.88	4.25	5.25	1.44	4.03
1-3/8 - 1-1/2	1010676	Bulk	700	1.50	4.13	1.56	3.00	1.00	5.56	7.00	1.63	4.66

4

Rigging Fittings

Malleable Wire Rope Clips

! WARNING !

- Failure to read, understand, and follow these instructions may cause injury and property damage.
- Read and understand these instructions before using malleable clips.
- Never use malleable clips for critical, heavy duty, or overhead loads, such as lifting slings, support lines, guy lines, towing lines, tie downs, scaffolds, etc.
- Malleable clips are to be used for making eye termination assemblies.
 - Only with right regular lay wire rope.
 - Only for non-critical light duty uses with small applied loads, such as hand rails, fencing, guard rails, etc.
- Apply first load to test the assembly. This load should be of equal or greater weight than loads expected in use. Next, check and retighten nuts to recommended torque (See Table 1).

NOTE: Never use malleable cups for critical, heavy duty, or overhead loads, such as lifting slings, support lines, guy lines, towing lines, tie downs, scaffolds, etc.

- Crosby G-450 Wire Rope Clips,
- Crosby G-429 Fist Grip Wire Rope Clips

The style of wire rope termination used for any application is the obligation of the user.

For OSHA (Construction) applications, see OSHA 1926.251.



Clip Size (in)	Min. No. of Clips	Amt. of Rope to Turn Back (in)	*Torque (ft/lbs)
1/8	3	4-3/4	3
3/16	3	5-1/2	4.5
1/4	3	7	15
5/16	3	7-3/4	15
3/8	3	9-1/2	30
7/16	3	10-1/4	40
1/2	4	15-1/4	45
9/16	4	16	50
5/8	4	16	75
3/4	5	22-1/4	75
7/8	5	23-1/2	130
1	6	31	130
1-1/8	7	39-1/2	200
1-1/4	8	50	200
1-3/8	8	50	360
1-1/2	9	60-1/2	360

If a pulley (sheave) is used for turning back the wire rope, add one additional clip. If a greater number of clips are used than shown in the table, the amount of turnback should be increased proportionately. *The tightening torque values shown are based upon the threads being clean, dry, and free of lubrication.

Continuous Cable Clamps

For attaching a load to a continuous cable without cutting the cable. Consists of a wedge clamp, wedge and cable clip. Use with 6-strand right regular lay wire rope, either fiber center or IWRC. Minimum safety factor of two with a working load one-third the breaking strength of improved plow steel fiber center wire rope.



Working loads are: 3/8" - 4000 lb.; 1/2" - 7000 lb.; 5/8" - 11,000 lb.; 3/4" - 15,000 lb.; 7/8" - 21,000 lb.; 1" - 27,000 lb.; 1-1/8" - 35,000 lb.; 1-1/4" - 43,000 lb

NOTE: If safety factor more than two is required, working loads should be reduced accordingly. Not approved for elevator service.

Part No. Does Not Include Clevis or Pin	Rope Size (in)	Clevis No.	Pin No.	Wt. Includes Only Wedge Clamp, Wedge Cable Clips (lbs)
CC-4195	3/8	C-4211	P-339	5
CC-4194	1/2	C-4211	P-339	5
CC-4192	5/8	C-4229	P-3404	12
CC-4191	3/4	C-4229	P-3404	12
CC-4190	7/8	C-4243	P-3710	22
CC-4188	1	C-4243	P-3710	23
CC-4186	1-1/8	C-4243	P-3710	38
CC-4199	1-1/4	C-42561	P-56936	57

Slip-Thru Thimble

Thimble Code	Sling Size				Dimension (in)								Wt. (lbs)
	Single	8 pt.	6 pt.	4 pt.	A	B	C	D	E ^R	F	G		
W-2	5/16 - 3/8	3/32 - 1/8	3/32 - 1/8	1/8 - 3/16	2-1/8	4-1/8	7/16	13/16	9/16	3-1/4	5-1/4	1.3	
W-3	1/2 - 9/16	3/16	3/16	1/4	2-3/8	4-3/8	5/8	1	5/8	4	6	1.15	
W-4	5/8 - 3/4	1/4	1/4 - 5/16	5/16 - 1/8	3-3/8	6-5/8	13/16	1-5/16	5/8	5-3/8	8-1/2	3.11	
W-5	7/8 - 1	5/16	3/8	7/16 - 1/2	3-3/4	7-1/8	1-1/8	1-5/8	7/8	6-1/4	9-3/8	5.6	
W-6	1-1/8 - 1-1/4	3/8	7/16	9/16 - 5/8	4-3/8	8-3/8	1-3/8	1-7/8	1	7-1/8	11	8.6	
W-7	1-3/8 - 1-1/2	7/16 - 1/2	1/2	3/4	5	9-1/2	1-5/8	2-1/8	1-1/4	8-1/8	12-1/2	11.1	
W-8	1-5/8 - 1-3/4	9/16	5/8	7/8	6-3/4	11-3/4	1-13/16	2-9/16	1-7/16	9-3/8	14-3/4	17.6	
W-9	1-7/8 - 2	5/8	3/4	1	8	14-1/2	2-1/8	3-1/4	1-7/8	13	19-1/4	53	
W-10	2-1/8 - 2-1/4	1/4	7/8 - 1	1-1/8 - 1-1/4	8	15-1/2	2-1/2	3-3/4	2	13	20-1/8	66	
W-11	2-3/4 - 3	7/8 - 1	1-1/8	1-1/4 - 1-3/8 - 1-1/2	9	18-1/2	3-3/16	4-11/16	2-1/2	15-3/4	24-3/4	126	



Designed to allow passage of an identical thimble through its eye. A necessity when a regular sling is used as a choker sling. A Slip-Thru Thimble also prevents the eye of the sling from mashing together, and the top of the eye from wearing excessively. Generous inside dimensions allow the thimbles to fit crane hooks.

Choker Thimble

Thimble Code	Sling Size		Dimension (in)								Wt. (lbs)
	6 pt.	8 pt.	A	B	C	D	E	F	G	H ^R	
82	1/8	1/8	1/2	7/8	1-1/4	2-1/8	3-1/4	1/4	3/8	5/16	.7
83	1/4	3/16	5/8	1	1-1/2	2-1/2	3-7/8	1/4	1/2	3/8	1.1
84	5/16	1/4	13/16	1-5/16	1-3/4	2-7/8	4-7/16	5/16	5/8	7/16	1.8
85	3/8	5/16	15/16	1-7/16	2	3-1/4	5	5/16	3/4	1/2	2.2
86	7/16	3/8	1-1/8	1-11/16	2-1/4	3-5/8	5-3/4	3/8	7/8	9/16	3.3
87	1/2	7/16	1-3/8	1-15/16	2-3/4	4-1/16	6-3/8	3/8	1	11/16	4.7

Choker Thimbles are designed especially for use with braided Choker slings. The ears can be easily peened over without fracturing.

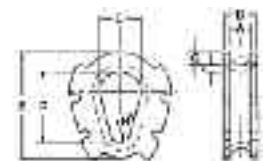

Thimbles

Crescent Thimble

Thimble Code	Sling Size					Dimension (in)								Wt. (lbs)
	Single	8 pt.	6 pt.	4 pt.		A	B	C	D	E	F	G	H	
6C	3/8 - 7/16	3/32	1/8	1/8 - 3/16	2	1	27/32	15/32	2-1/16	3/8	1/2	3/8	1/2	.75
8C	1/2 - 9/16	1/8	3/16	1/4	2-1/4	1-1/8	1	5/8	2-1/2	1/2	1/2	1/2	1.0	
9C	5/8	3/16	1/4	5/16	2-3/4	1-3/8	1-5/32	23/32	3	19/32	9/16	9/16	1.2	
10C	3/4	1/4	5/16	3/8	3-1/4	1-5/8	1-5/16	13/16	3-1/2	5/8	5/8	5/8	2.0	
14C	7/8	5/16	3/8	7/16	4-1/2	2-1/4	1-7/16	15/16	4-5/16	3/4	11/16	3/4	3.3	
16C	1	3/8	7/16	1/2	4-1/2	2-1/4	1-9/16	1-1/16	4-19/32	13/16	3/4	7/8	3.8	
18C	1-1/8	7/16	1/2	9/16	4-7/8	2-7/16	1-13/16	1-1/4	5-1/32	7/8	7/8	1	5.0	
20C	1-1/4	1/2	9/16	5/8	5-1/2	2-3/4	2-1/16	1-7/16	5-3/4	15/16	15/16	1-1/8	6.8	
22C	1-3/8 - 1-1/2	9/16	5/8	3/4	6	3	2-1/4	1-5/8	6-1/4	1-1/16	1-1/8	1-3/16	9.0	
24C	1-5/8	5/8	3/4	-	6-1/2	3-1/4	2-1/2	1-3/4	6-11/16	1-1/8	1-1/4	1-1/4	12.0	
28C	1-3/4 - 1-7/8	3/4	7/8	7/8	7	3-1/2	2-15/16	1-15/16	7-3/8	1-1/4	1-3/8	1-1/2	16.6	
32C	2	7/8	1	1	7	3-1/2	3-3/16	2-3/16	7-13/16	1-1/2	1-1/2	1-5/8	21.8	
40C	2-1/4 - 2-1/2	1	1-1/8	1-1/8 - 1-1/4	8-1/2	4-1/4	4-1/8	2-7/8	9-5/8	1-5/8	1-7/8	2	39.0	
48C	2-3/4 - 3	1-1/8	1-1/4	-	10	5	4-7/8	3-3/8	11-1/4	1-3/4	2-1/4	2-1/2	67.0	

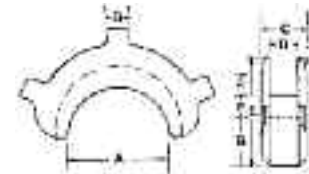

Designed to protect the bearing surface of an eye where a large dimension eye is necessary. The ears are tapered so that they can be bent over.

Open Pattern Thimbles

- Recommended for light duty service.
- Hot dip galvanized steel.

Rope Dia. (in)	G-408 Stock No.	Wt. Per 100 (lbs)	Dimensions (in)					
			A	B	C	D	E	F
1/4	1037531	3.00	.28	.69	1.06	1.41	2.03	.38
5/16	1037559	3.80	.34	.81	1.25	1.53	2.16	.50
3/8	1037577	7.00	.44	.94	1.47	1.72	2.47	.62
1/2	1037595	12.50	.53	1.12	1.75	1.47	2.84	.75
5/8	1037611	25.00	.66	1.38	2.38	2.34	3.59	1.00



Extra Heavy Wire Rope Thimbles

- A rugged rope thimble recommended for heavy duty service.
- Available in hot dip galvanized or stainless steel*.



Rope Dia. (in)	Stock No.	G-414 Galv.	S-414 Stainless	Wt. Per 100 (lbs)	Dimensions (in)							
					A	B	C	D	E	F	G	H
*1/4	1037639	1037960		6.50	2.19	1.63	1.50	.88	.41	.28	.06	.23
*5/16	1037657	1037988		11.80	2.50	1.88	1.81	1.06	.50	.34	.08	.28
*3/8	1037675	1038004		21.60	2.88	2.13	2.13	1.13	.63	.41	.11	.34
7/16	1037693	-		34.70	3.25	2.38	2.38	1.25	.72	.47	.13	.38
*1/2	1037719	1038022		51.00	3.63	2.75	2.75	1.50	.81	.53	.14	.41
9/16	1037737	-		51.00	3.63	2.75	2.69	1.50	.88	.59	.14	.41
*5/8	1037755	1038040		75.70	4.25	3.25	3.13	1.75	.97	.66	.16	.50
*3/4	1037773	1038068		158.10	5.00	3.75	3.81	2.00	1.22	.78	.22	.66
7/8	1037791	-		177.80	5.50	4.25	4.25	2.25	1.38	.94	.22	.75
1	1037817	-		313.90	6.13	4.50	4.94	2.50	1.56	1.06	.25	.88
1-1/8 - 1-1/4	1037835	-		400.00	7.00	5.13	5.88	2.88	1.81	1.31	.25	1.13
1-1/4 - 1-3/8	1037853	-		811.00	9.06	6.50	6.81	3.50	2.19	1.44	.38	1.13
1-3/8 - 1-1/2	1037871	-		1294.80	9.00	6.25	7.13	3.50	2.56	1.56	.50	1.13
1-5/8	1037899	-		1700.00	11.25	8.00	8.13	4.00	2.72	1.72	.50	1.38
1-3/4	1037915	-		1775.00	12.19	9.00	8.50	4.50	2.84	1.84	.50	1.31
1-7/8 - 2	1037933	-		2775.00	15.13	12.00	10.38	6.00	3.09	2.09	.50	1.50
2-1/4	1037951	-		3950.00	17.13	14.00	11.88	7.00	3.63	2.38	.63	1.63

Standard Wire Rope Thimbles

- Recommended for light duty service.
- Hot dip galvanized steel.

Rope Dia. (in)	G-411 Stock No.	Wt. Per 100 (lbs)	Dimensions (in)							
			A	B	C	D	E	F	G	H
1/8	1037256	3.50	1.94	1.31	1.06	.69	.25	.16	.05	.13
3/16	1037274	3.50	1.94	1.31	1.06	.69	.31	.22	.05	.13
1/4	1037292	3.50	1.94	1.31	1.06	.69	.38	.28	.05	.13
5/16	1037318	4.00	2.13	1.50	1.25	.81	.44	.34	.05	.13
3/8	1037336	6.70	2.38	1.63	1.47	.94	.53	.41	.06	.16
1/2	1037354	12.50	2.75	1.88	1.75	1.13	.69	.53	.08	.19
5/8	1037372	34.50	3.50	2.25	2.38	1.38	.91	.66	.13	.34
3/4	1037390	47.10	3.75	2.50	2.69	1.63	1.06	.78	.14	.34
7/8	1037416	84.60	5.00	3.50	3.19	1.88	1.27	.94	.16	.44
1	1037434	97.50	5.69	4.25	3.75	2.50	1.39	1.06	.16	.41
1-1/8 - 1-1/4	1037452	175.00	6.25	4.50	4.31	2.75	1.75	1.31	.22	.50

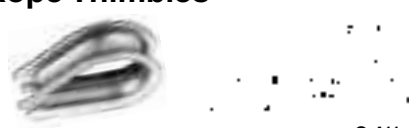

Solid Wire Rope Thimbles

- Fits pin for open wire rope socket, boom pendant clevis and wedge socket.

† Cast Ductile Iron.

Rope Dia. (in)	S-412 Stock No.	Wt. Each (lbs)	Dimensions (in)										
			A	B	C	D	E	F	G	H	J	K	L
1/2	1037121	.61	2.81	1.75	.25	1.06	.75	.56	.28	.88	2.13	1.63	1.56
5/8	1037149	2.21	4.69	3.00	.38	1.31	1.06	.81	.41	1.13	3.38	2.25	2.56
3/4	1037167	2.32	4.69	3.00	.38	1.50	1.06	.81	.41	1.38	3.38	2.25	2.56
7/8	1037185	5.45	6.06	3.81	.50	1.75	1.38	1.06	.53	1.63	4.50	3.25	3.44
1	1037201	5.25	6.06	3.81	.50	2.13	1.38	1.06	.53	1.81	4.50	3.25	3.44
1-1/8	1037229	9.29	7.25	4.56	.63	2.38	1.75	1.31	.66	2.06	5.38	3.88	4.06
1-1/4 - 1-3/8	1037247	9.81	7.25	4.56	.63	2.63	1.94	1.53	.78	2.31	5.38	3.88	4.13



Equalizing Thimble

Rope Size Dia. (in)	Part No.	L	W	T	Approx. Wt. (lbs)
3/8 - 7/16	3E	4-1/2	3	7/8	3.0
1/2 - 9/16	4E	6	4	1-1/8	6.3
5/8 - 3/4	6E	7	4-1/2	1-7/16	9.8
7/8 - 1	8E	9	5-1/2	1-13/16	15.6
1-1/8 - 1-1/4	10E	10	6-1/2	2-3/16	28
1-3/8 - 1-1/2	12E	11	7-1/2	2-9/16	39
1-5/8 - 1-3/4	14E	15	9	2-15/16	65
1-7/8 - 2	16E	15	9	3-15/16	85
5/8 - 3/4	DG6E	8-1/4	5-1/2	2-3/8	21
7/8 - 1	DG8E	9	6	2-7/8	28
1-1/8 - 1-1/4	DG10E	11-1/2	7-1/2	3-1/4	45

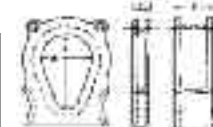

This cast steel thimble permits adjusting of the length of sling legs so that loads varying in dimension may be picked up and handled on an even keel.

Note: DG - Designates Double Groove Equalizing Thimble

Heavy Duty Stainless Steel Thimbles

Part No.	To Fit Cable Dia.	A1	A2	B	L1	L2	Thickness Comparison		Wt. Each & Comparison	
							Heavy Duty (S)	AN Type (E)	Heavy Duty	AN Type
EY 18-3*	3/32	.118	.393	.196	.866	.590	.039	.032	.44	.43
EY 18-4*	1/8	.157	.393	.255	.984	.629	.047	.032	.88	.43
EY 18-5*	5/32	.196	.472	.295	1.062	.708	.047	.032	1.1	.6
EY 18-6*	3/16	.236	.511	.334	1.259	.826	.059	.032	2.2	.98
EY 18-8*	1/4	.275	.590	.393	1.496	1.023	.059	.032	2.64	1.5
EY 18-9*	9/32	.314	.748	.433	1.771	1.220	.078	.040	4.4	3.5
EY18-10*	5/16	.354	.866	.511	1.968	1.456	.078	.040	5.94	3.5
EY 18-12*	3/8	.393	.944	.551	2.283	1.614	.098	.060	8.8	8.5
EY 18-16*	1/2	.551	1.141	.669	2.755	2.047	.118	-	16.28	-



Rigging Fittings

Thimbles/Shackles

AN 100 Thimbles

AN thimbles come in either cold-rolled steel (zinc plated) or stainless steel (natural finish). Fit cable diameters from 1/16" to 3/8" to meet the most demanding marine, aircraft or industrial requirements. AN Thimbles meet all Military, Specifications.

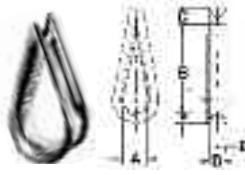

To Fit Cable Dia. (in)	Cold Rolled Steel Zinc Plated Part No.	Stainless Steel Part No.	Dimensions(in)						Wt. Per 1,000 (lbs)
			A	B	C	D	E	F	
3/64-1/16-5/64-3/32	AN 100-3*	AN 100-C3*	.350	43/64	3/16	3/32	.032	5/64	1.5
3/32-7/64-1/8	AN 100-4*	AN 100-C4*	.350	45/64	7/32	9/64	.032	5/64	4.3
5/32	AN 100-5*	AN 100-C5*	.400	51/64	7/32	11/64	.032	7/64	6
3/16	AN 100-6*	AN 100-C6*	.500	1	5/16	13/64	.032	11/64	9.8
7/32-1/4	AN 100-8*	AN 100-C8*	.700	1-13/32	13/32	17/64	.032	11/64	15
9/32-5/16	AN 100-10*	AN 100-C10*	.900	1-51/64	7/16	21/64	.040	7/32	35
3/8	AN 100-12*	AN 100-C12*	1.000	2	5/8	25/64	.060	17/64	85

Synthetic Rope Thimbles

For use with all types of synthetic ropes. Larger sizes have rope retaining rings. Injection molded from tough, wear-resistant polyallomer material. Good abrasive wear. Ideal for use with lanyards, hand lines, mooring lines.

Round Shape

Rope Dia. (in.)	Dimensions (in)						Wt. Per 100 Pcs. (lbs)
	A	B	C	D	E	F	
7/16	1-3/32	1-3/32	5/8	5/8	9/16	1/2	.4
1/2	1-3/8	1-3/8	11/16	11/16	3/4	9/16	1.1
5/8	2-3/16	2-3/16	1-1/8	1-1/8	7/8	11/16	3.0

Oval (Teardrop Shape)

Rope Dia. (in.)	Dimensions (in)						Wt. Per 100 Pcs. (lbs)
	A	B	C	D	E	F	
*1/8	1-1/4	3/4	7/8	7/16	9/32	5/32	.16
*3/16	1-11/16	1-1/16	1-1/4	11/16	11/32	7/32	.35
1/4	1-3/4	1-5/8	1-5/16	11/16	7/16	5/16	.7
3/8	2-5/16	2-1/16	1-1/2	25/32	19/32	7/16	1.5
1/2	3	2-11/16	1-7/8	1-1/8	25/32	9/16	3.5
5/8	3-7/16	3-1/4	2-1/2	1-3/8	15/16	1-1/16	5

* 1/4 Synthetic Thimble
Dimensions are Approx. Do not have ears.

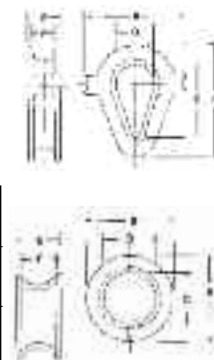

Forged Shackles - Crosby®

- Working Load Limit permanently shown on every shackle.
- Forged - Quenched and Tempered, with alloy pins.
- Capacities 1/3 thru 55 tons.
- Shackles can be furnished proof tested with certificates to designated standards, such as ABS, DNV Lloyds or other certification. Charges for proof testing and certification available when requested at the time of order.
- Hot Dip galvanized or Self Colored.
- Fatigue rated.

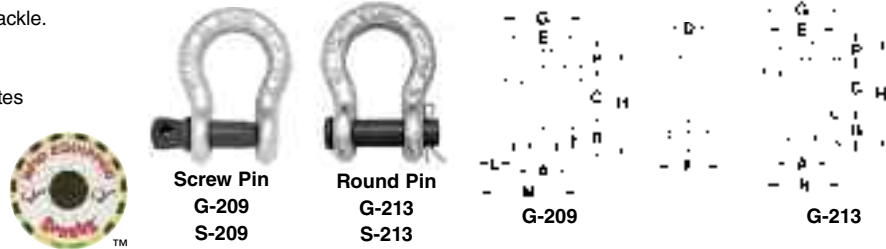

Nom. Size (in)	* WLL (ton)	Stock No.				Wt. Each (lbs)	
		G-209 Galv.	S-209 S.C.	G-213 Galv.	S-213 S.C.	G-209 S-209	G-213 S-213
3/16	1/3†	1018357	-	-	-	.06	-
1/4	1/2	1018375	1018384	1018017	1018026	.10	.13
5/16	3/4	1018393	1018400	1018035	1018044	.19	.18
3/8	1	1018419	1018428	1018053	1018062	.31	.29
7/16	1-1/2	1018437	1018446	1018071	1018080	.38	.38
1/2	2	1018455	1018464	1018099	1018106	.72	.71
5/8	3-1/4	1018473	1018482	1018115	1018124	1.37	1.50
3/4	4-3/4	1018491	1018507	1018133	1018142	2.35	2.32
7/8	6-1/2	1018516	1018525	1018151	1018160	3.62	3.49
1	8-1/2	1018534	1018543	1018179	1018188	5.03	5.00
1-1/8	9-1/2	1018552	1018561	1018197	1018204	7.41	6.97
1-1/4	12	1018570	1018589	1018213	1018222	9.50	9.75
1-3/8	13-1/2	1018598	1018605	1018231	1018240	13.53	13.25
1-1/2	17	1018614	1018623	1018259	1018268	17.20	17.25
1-3/4	25	1018632	1018641	1018277	1018286	27.78	29.46
2	35	1018650	1018669	1018295	1018302	45.00	45.75
2-1/2	55†	1018678	1018687	-	-	85.75	-

Nom. Size (in)	Wkng. Load (tons)	Dimensions (in)														Tolerance +/-	
		A	B	C	D	E	F	G	H	L	M	N	P	C	A		
3/16	1/3†	.38	.25	.38	.19	.60	.56	.98	1.47	.16	1.12	-	.19	.06	.06		
1/4	1/2	.47	.31	1.13	.25	.78	.61	1.28	1.84	.19	1.38	1.34	.25	.06	.06		
5/16	3/4	.53	.38	1.22	.31	.84	.75	1.47	2.09	.22	1.66	1.59	.31	.06	.06		
3/8	1	.66	.44	1.44	.38	1.03	.91	1.78	2.49	.25	2.03	1.86	.38	.13	.06		
7/16	1-1/2	.75	.50	1.69	.44	1.16	1.06	2.03	2.91	.31	2.38	2.13	.44	.13	.06		
1/2	2	.81	.63	1.88	.50	1.31	1.19	2.31	3.28	.38	2.69	2.38	.50	.13	.06		
5/8	3-1/4	1.06	.75	2.38	.63	1.69	1.50	2.94	4.19	.44	3.34	2.91	.69	.13	.06		
3/4	4-3/4	1.25	.88	2.81	.75	2.00	1.81	3.50	4.97	.50	3.97	3.44	.81	.25	.06		
7/8	6-1/2	1.44	1.00	3.31	.88	2.28	2.09	4.03	5.83	.50	4.50	3.81	.97	.25	.06		
1	8-1/2	1.69	1.13	3.75	1.00	2.69	2.38	4.69	6.56	.56	5.07	4.53	1.06	.25	.06		
1-1/8	9-1/2	1.81	1.25	4.25	1.16	2.91	2.69	5.16	7.47	.63	5.59	5.13	1.25	.25	.06		
1-1/4	12	2.03	1.38	4.69	1.29	3.25	3.00	5.75	8.25	.69	6.16	5.50	1.38	.25	.06		
1-3/8	13-1/2	2.25	1.50	5.25	1.42	3.63	3.31	6.38	9.16	.75	6.84	6.13	1.50	.25	.13		
1-1/2	17	2.38	1.63	5.75	1.54	3.88	3.63	6.88	10.00	.81	7.35	6.50	1.62	.25	.13		
1-3/4	25	2.88	2.00	7.00	1.84	5.00	4.19	8.86	12.34	1.00	9.08	7.75	2.25	.25	.13		
2	35	3.25	2.25	7.75	2.08	5.75	4.81	9.97	13.68	1.22	10.34	8.75	2.40	.25	.13		
2-1/2	55†	4.13	2.75	10.50	2.71	7.25	5.69	12.87	17.84	1.38	13.00	-	3.13	.25	.25		

* NOTE: Maximum Proof Load is 2.0 times the Working Load Limit. Minimum Ultimate Strength is 6 times the Working Load Limit. † Furnished in screw pin only.

Long Reach Shackle

Load Rated Long Reach Carbon Steel Shackles were developed for those special situations when a standard shackle needs that little extra reach to get the job done right. Offered in two body sizes, the 3/4" body with 7/8" pin rated at a WLL (working load limit) of 10,000 lbs. and a 1" body with a 1" pin rated at 19,000 lbs. WLL. Born out of customer demand, these two highly versatile shackles will prove to be an indispensable addition to the riggers' toolbox. The open design, extra long reach and generous load bearing surfaces will accommodate many rigging hookups that a standard shackle cannot reach. As with all rigging gear, extreme care should be taken to center loads and observe the working load limit of each component of your hookup.



Working Load Limit (lb)	Screw Pin Product Code		Weight (lb)	Bolt Type Product Code		Weight (lb)	P	D	L	W	G
	Self Colored	Painted		Self	Painted						
Imperial											
7,000	M7151	M7151P	1.80	M9151	M9151P	1.95	0.75	0.63	4.00	2.25	1.57
10,000	M7152	M7152P	2.72	M9152	M9152P	3.21	0.88	0.75	4.56	2.75	1.81
19,000	M7154	M7154P	5.86	M9154	M9154P	6.31	1.00	1.00	5.50	3.25	2.38
28,000	M7156	M7156P	11.90	M9156	M9156P	12.90	1.38	1.25	6.25	3.88	3.06
34,000	M7157	M7157P	19.60	M9157	M9157P	20.70	1.63	1.50	7.00	4.50	3.50
50,000	M7177	M7177P	30.70	M9177	M9177P	33.30	2.00	1.75	8.00	5.25	4.00

Shackles

Anchor Shackles/Screw Pin

Crosby® G-209-A

- Capacities 2 thru 21 metric tons.
- Forged Alloy Steel - Quenched and Tempered, with alloy pins.
- Working Load Limit permanently shown on every shackle.
- Hot Dip Galvanized.
- Shackles can be furnished proof tested with certificates to designated standards, such as ABS, DNV, Lloyds, or other certification. Charges for proof testing and certification available when requested at the time of order.
- Meets or exceeds all requirements of ASME B30.26 including identification, ductility, design factor, proof load and temperature requirements. Importantly, these shackles meet other critical performance requirements including fatigue life, impact properties and material traceability, not addressed by ASME B30.26.

G-209a Screw pin anchor shackles meet the performance requirements of Federal Specification RR-C271D Type IVA, Grade B, Class 2, except for those provisions required of the contractor.



G-209-A



Nominal Size (in.)	Working Load Limit (t)*	G-209-A Stock No.	Weight (lbs)	Dimensions (in)												Tolerance +/-		
				A	B	C	D	E	F	G	H	L	M	P	C	A		
3/8	2	1017450	.31	.66	.44	1.44	.38	1.03	.91	1.78	2.49	.25	2.03	.38	.13	.06		
7/16	2-2/3	1017472	.38	.75	.50	1.69	.44	1.16	1.06	2.03	2.91	.31	2.38	.44	.13	.06		
1/2	3-1/3	1017494	.63	.81	.63	1.88	.50	1.31	1.19	2.31	3.28	.38	2.69	.50	.13	.06		
5/8	5	1017516	1.38	1.06	.75	2.38	.63	1.69	1.50	2.94	4.19	.44	3.34	.69	.13	.06		
3/4	7	1017538	2.25	1.25	.88	2.81	.75	2.00	1.81	3.50	4.97	.50	3.97	.81	.25	.06		
7/8	9-1/2	1017560	3.61	1.44	1.00	3.31	.88	2.28	2.09	4.03	5.83	.50	4.50	.97	.25	.06		
1	12-1/2	1017582	5.32	1.69	1.13	3.75	1.00	2.69	2.38	4.69	6.56	.56	5.07	1.06	.25	.06		
1-1/8	15	1017604	7.25	1.81	1.25	4.25	1.16	2.91	2.69	5.16	7.47	.63	5.59	1.25	.25	.06		
1-1/4	18	1017626	9.88	2.03	1.38	4.69	1.29	3.25	3.00	5.75	8.25	.69	6.16	1.38	.25	.06		
1-3/8	21	1017648	13.25	2.25	1.50	5.25	1.42	3.63	3.31	6.38	9.16	.75	6.84	1.50	.25	.13		

* Maximum Proof Load is 2 times the Working Load Limit (metric tons) and 2.2 times the Working Load Limit (short tons). Minimum Ultimate Strength is 4.5 times the Working Load Limit for metric tons, and 5 times the Working Load Limit for short tons.

Anchor Shackles/Screw Pin

GRADE: 316-NM
 STAINLESS STEEL

I/A/W Fed Spec RR-C-271D,
 Type IVA, Class 2, Except 316 Stainless,
 Drop Forged and Load Rated

This anchor shackle is made from grade 316 stainless steel and features an oversize screw pin. Stainless steel anchor shackle is ideal for salt water applications. This anchor shackle meets ASME B30.26.2004 American National Standard and is also DFARS compliant.

Item	Dimensions (in)				WLL (lb)	WT (lb)
	A (size)	B	C	D		
S0116-US07	1/4	0.31	0.47	1.11	1,000	0.10
S0116-US08	5/16	0.38	0.53	1.20	1,300	0.17
S0116-US10	3/8	0.44	0.66	1.41	1,500	0.30
S0116-US12	7/16	0.50	0.72	1.77	2,000	0.50
S0116-US13	1/2	0.63	0.82	1.83	3,000	0.71
S0116-US16	5/8	0.75	1.02	2.41	4,000	1.39
S0116-US20	3/4	0.88	1.25	2.84	6,000	2.31
S0116-US22	7/8	1.00	1.48	3.30	8,000	3.64
S0116-US25	1	1.13	1.70	3.80	10,000	5.18



Anchor Shackles/Round Pin

GRADE: 316-NM
 STAINLESS STEEL

I/A/W Fed Spec RR-C-271D,
 Type IVA, Class 1, Except 316
 Stainless, Drop Forged
 and Load Rated

The Round Pin Anchor Shackle is made from grade 316 stainless steel and features an oversize round pin. Stainless steel Anchor Shackle is ideal for salt water applications. The Round Pin Anchor Shackle is primarily used to connect the anchor to the chain or anchor swivel.

Item	Dimensions (in)				WLL (lb)	WT (lb)
	A (size)	B	C	D		
S0116-RP07	1/4	0.31	0.47	1.11	1,000	0.10
S0116-RP08	5/16	0.38	0.53	1.20	1,300	0.17
S0116-RP10	3/8	0.44	0.66	1.41	1,500	0.32
S0116-RP12	7/16	0.50	0.72	1.77	2,000	0.49
S0116-RP13	1/2	0.63	0.82	1.83	3,000	0.72
S0116-RP16	5/8	0.75	1.02	2.41	4,000	1.53
S0116-RP20	3/4	0.88	1.25	2.84	6,000	2.36
S0116-RP22	7/8	1.00	1.48	3.30	8,000	4.00
S0116-RP25	1	1.13	1.70	3.80	10,000	4.27
S0116-RP32	1-1/4	1.38	2.03	4.69	14,000	9.88

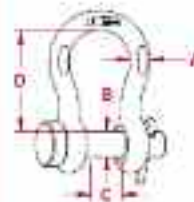

Bolt Anchor Shackles Safety

GRADE: 316-NM STAINLESS STEEL

I/A/W Fed Spec RR-C-271D, Type IVA,
 Class 3, Except 316 Stainless,
 Drop Forged and Load Rated

The Bolt Anchor Shackle is made from grade 316 stainless steel and features an oversize bolt. Stainless steel anchor shackle with oversize bolt is ideal for salt water applications. The Bolt Anchor Shackle is primarily used to connect the anchor to the chain or anchor swivel.

Item	Dimensions (in)				WLL (lb)	WT (lb)
	A (size)	B	C	D		
S0116-SA07	1/4	0.31	0.47	1.11	1,000	0.12
S0116-SA08	5/16	0.38	0.53	1.20	1,300	0.18
S0116-SA10	3/8	0.44	0.66	1.41	1,500	0.35
S0116-SA12	7/16	0.50	0.72	1.77	2,000	0.57
S0116-SA13	1/2	0.63	0.82	1.83	3,000	0.84
S0116-SA16	5/8	0.75	1.02	2.41	4,000	1.64
S0116-SA20	3/4	0.88	1.25	2.84	6,000	2.75
S0116-SA22	7/8	1.00	1.48	3.30	8,000	4.18
S0116-SA25	1	1.13	1.70	3.80	10,000	5.61
S0116-SA32	1-1/4	1.38	2.03	4.69	14,000	9.88

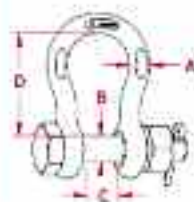

Rigging Fittings

Shackles

Bolt-Type Shackles - Crosby®

- Working Load Limit permanently shown on every shackle. Capacities 1/3 thru 150 tons.
- Forged - Quenched and Tempered, with alloy pins.
- Shackles 55 tons and smaller can be furnished proof tested with certificates to designated standards, such as ABS, DNV, Lloyds, or other certification.
- Certification must be requested at time of order.
- Shackles 85 tons and larger can be provided as follows.
 - Non Destructive Tested.
 - Material Certification (Chemical)- Serialized Pin and Bow.
 - Certification must be requested at time of order.
 - Hot Dip galvanized or Self Colored.
- Fatigue rated.



Bolt Type Anchor Shackle
G-2130 S-2130

Bolt Type Chain Shackle
G-2150 S-2150

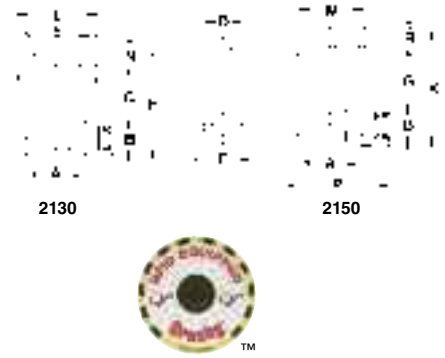

Shackles 25t and larger are RFID EQUIPPED.

Nom. Size (in)	WLL* (ton)	Stock No.				Wt. Each (lbs)		Nominal Shackle Size (in)	WLL* (tons)	Dimensions (in)														Tolerance +/-	
		G-2130 Galv.	S-2130 S.C.	G-2150 Galv.	S-2150 S.C.	G-2130 S-2130	G-2150 S-2150			A	B	C	D	E	F	G	H	K	L	M	N	P	R	C&G	A
3/16	*1/3	1019464	-	-	-	.06	-	3/16	*1/3	.38	.25	.88	.19	.60	.56	-	1.47	-	.98	-	.19	1.29	-	.06	.06
1/4	1/2	1019466	-	1019768	-	.11	.13	1/4	1/2	.47	.31	1.13	.25	.78	.61	.75	1.84	1.59	1.28	.97	.25	1.56	.25	.06	.06
5/16	3/4	1019468	-	1019770	-	.22	.23	5/16	3/4	.53	.38	1.22	.31	.84	.75	1.00	2.09	1.91	1.47	1.16	.31	1.82	.31	.06	.06
3/8	1	1019470	-	1019772	-	.33	.33	3/8	1	.66	.44	1.44	.38	1.03	.91	1.22	2.49	2.30	1.78	1.41	.38	2.17	.38	.13	.06
7/16	1-1/2	1019471	-	1019774	-	.49	.49	7/16	1-1/2	.75	.50	1.69	.44	1.16	1.06	1.42	2.91	2.66	2.03	1.62	.44	2.51	.44	.13	.06
1/2	2	1019472	1019481	1019775	1019784	.79	.75	1/2	2	.81	.63	1.88	.50	1.31	1.19	1.63	3.28	3.03	2.31	1.81	.50	2.80	.50	.13	.06
5/8	3-1/4	1019490	1019506	1019793	1019800	1.68	1.47	5/8	3-1/4	1.06	.75	2.38	.63	1.69	1.50	2.00	4.19	3.75	2.94	2.31	.69	3.53	.63	.13	.06
3/4	4-3/4	1019515	1019524	1019819	1019828	2.72	2.52	3/4	4-3/4	1.25	.88	2.81	.75	2.00	1.81	2.38	4.97	4.53	3.50	2.75	.81	4.07	.81	.25	.06
7/8	6-1/2	1019533	1019542	1019837	1019846	3.95	3.85	7/8	6-1/2	1.44	1.00	3.31	.88	2.28	2.09	2.81	5.83	5.33	4.03	3.19	.97	4.71	.97	.25	.06
1	8-1/2	1019551	1019560	1019855	1019864	5.66	5.55	1	8-1/2	1.69	1.13	3.75	1.00	2.69	2.38	3.19	6.56	5.94	4.69	3.69	1.06	5.31	1.00	.25	.06
1-1/8	9-1/2	1019579	1019588	1019873	1019882	8.27	7.60	1-1/8	9-1/2	1.81	1.25	4.25	1.13	2.91	2.69	3.58	7.47	6.78	5.16	4.06	1.25	5.90	1.25	.25	.06
1-1/4	12	1019597	1019604	1019891	1019908	11.71	10.81	1-1/4	12	2.03	1.38	4.69	1.25	3.25	3.00	3.94	8.25	7.50	5.75	4.53	1.38	6.51	1.38	.25	.06
1-3/8	13-1/2	1019613	1019622	1019917	1019926	15.83	13.75	1-3/8	13-1/2	2.25	1.50	5.25	1.38	3.63	3.31	4.38	9.16	8.28	6.38	5.00	1.50	7.21	1.50	.25	.13
1-1/2	17	1019631	1019640	1019935	1019944	20.80	18.50	1-1/2	17	2.38	1.63	5.75	1.50	3.88	3.63	4.81	10.00	9.06	6.88	5.38	1.62	7.73	1.62	.25	.13
1-3/4	25	1019659	1019668	1019953	1019962	33.91	31.40	1-3/4	25	2.88	2.00	7.00	1.75	5.00	4.19	5.75	12.34	10.97	8.86	6.38	2.25	9.05	2.12	.25	.13
2	35	1019677	1019686	1019971	1019980	52.25	46.75	2	35	3.25	2.25	7.75	2.00	5.75	4.81	6.75	13.68	12.28	9.97	7.25	2.40	10.41	2.00	.25	.13
2-1/2	55	1019695	1019702	1019999	1020004	98.25	85.00	2-1/2	55	4.13	2.75	10.50	2.62	7.25	5.69	8.00	17.84	14.84	12.87	9.38	3.13	13.56	2.62	.25	.25
3	85†	1019711	-	1020013	-	154.00	124.25	3	85†	5.00	3.25	13.00	3.00	7.88	6.50	8.50	21.50	16.88	14.36	11.00	3.62	16.50	3.50	.25	.25
3-1/2	*120†	1019739	-	-	-	265.00M	-	3-1/2	*120†	5.25	3.75	14.63	3.62	9.00	8.00	-	24.63	-	16.50	-	4.12	19.00	-	.25	.25
4	*150†	1019757	-	-	-	338.00	-	4	*150†	5.50	4.25	14.50	4.10	10.00	9.00	-	25.69	-	18.42	-	4.56	19.75	-	.25	.25

† Individually Proof tested w/certification & furnished w/Hex Head Bolts.
 NOTE: Maximum Proof Load is 2.0 times the Working Load Limit.

* Furnished in Anchor style only.
 Minimum Ultimate Strength is 6 times the Working Load Limit.

Forged Chain Shackles - Crosby®

- Working Load Limit permanently shown on every shackle.
- Forged - Quenched and Tempered, with alloy pins.
- Capacities 1/3 thru 55 tons.
- Shackles can be furnished proof tested with certificates to designated standards, such as ABS, DNV, Lloyds or other certification. Charges for proof testing and certification available when requested at the time of order.
- Hot Dip galvanized or Self Colored.
- Fatigue rated.



Screw Pin
G-210 S-210

Round Pin
G-215 S-215

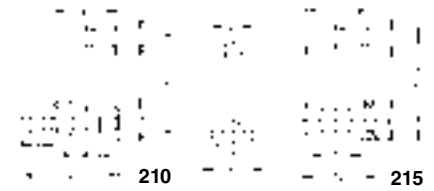

Shackles 25t and larger are RFID EQUIPPED.

Nom. Size (in)	WLL* (ton)	Stock No.				Wt. Each (lbs)		Nominal Size (in)	WLL (tons)	Dimensions (in)														Tolerance +/-	
		G-210 Galv.	S-210 S.C.	G-215 Galv.	S-215 S.C.	G-210 S-210	G-215 S-215			A	B	C	D	E	F	G	K	L	M	N	P	R	G	A	
1/4	1/2	1019150	1019169	1018810	1018829	.11	.10	1/4	1/2	.47	.31	.25	.25	.97	.61	.88	1.59	.19	1.38	1.34	.06	.06			
5/16	3/4	1019178	1019187	1018838	1018847	.17	.18	5/16	3/4	.53	.38	.31	.31	1.16	.75	1.03	1.91	.22	1.66	1.59	.06	.06			
3/8	1	1019196	1019203	1018856	1018865	.28	.25	3/8	1	.66	.44	.38	.38	1.41	.91	1.25	2.30	.25	2.03	1.86	.13	.06			
7/16	1-1/2	1019212	1019221	1018874	1018883	.43	.40	7/16	1-1/2	.75	.50	.44	.44	1.63	1.06	1.44	2.66	.31	2.38	2.13	.13	.06			
1/2	2	1019230	1019249	1018892	1018909	.59	.50	1/2	2	.81	.63	.50	.50	1.81	1.19	1.63	3.03	.38	2.69	2.38	.13	.06			
5/8	3-1/4	1019258	1019267	1018918	1018927	1.25	1.21	5/8	3-1/4	1.06	.75	.62	.63	2.31	1.50	2.00	3.75	.44	3.34	2.91	.13	.06			
3/4	4-3/4	1019276	1019285	1018936	1018945	2.63	2.00	3/4	4-3/4	1.25	.88	.81	.75	2.75	1.81	2.38	4.53	.50	3.97	3.44	.25	.06			
7/8	6-1/2	1019294	1019301	1018954	1018963	3.16	3.28	7/8	6-1/2	1.44	1.00	.97	.88	3.19	2.09	2.81	5.33	.50	4.50	3.81	.25	.06			
1	8-1/2	1019310	1019329	1018972	1018981	4.75	4.75	1	8-1/2	1.69	1.13	1.00	1.00	3.69	2.38	3.19	5.94	.56	5.07	4.53	.25	.06			
1-1/8	9-1/2	1019338	1019347	1018990	1019007	6.75	6.30	1-1/8	9-1/2	1.81	1.25	1.25	1.13	4.06	2.69	3.58	6.78	.63	5.59	5.13	.25	.06			
1-1/4	12	1019356	1019365	1019016	1019025	9.06	9.00	1-1/4	12	2.03	1.38	1.38	1.25	4.53	3.00	3.94	7.50	.69	6.16	5.50	.25	.13			
1-3/8	13-1/2	1019374	1019383	1019034	1019043	11.63	12.00	1-3/8	13-1/2	2.25	1.50	1.50	1.38	5.00	3.31	4.38	8.28	.75	6.84	6.13	.25	.13			
1-1/2	17	1019392	1019409	1019052	1019061	15.95	16.15	1-1/2	17	2.38	1.63	1.62	1.50	5.38	3.62	4.81	9.06	.81	7.35	6.50	.25	.13			
1-3/4	25	1019418	1019427	1019070	1019089	26.75	29.96	1-3/4	25	2.88	2.00	2.12	1.75	6.38	4.19	5.75	10.97	1.00	9.08	7.75	.25	.13			
2	35	1019436	1019445	1019098	1019105	42.31	43.25	2	35	3.25	2.25	2.00	2.00	7.25	4.81	6.75	12.28	1.22	10.34	8.75	.25	.13			
2-1/2	55†	1019454	1019463	-	-	71.75	-	2-1/2	55†	4.13	2.75	2.62	2.62	9.38	5.69	8.00	14.84	1.38	13.00	-	.25	.25			

* NOTE: Maximum Proof Load is 2.0 times the Working Load Limit. Minimum Ultimate Load is 6 times the Working Load Limit. † Furnished in screw pin only.

Shackles

Alloy Shackles - "Wide Body" Sling Saver Shackles Increase Sling Life - Crosby® G-2160

- All sizes Quenched and Tempered for maximum strength.
- Forged alloy steel from 7 through 300 metric tons.
- Cast alloy steel from 400 through 1550 metric tons.
- Sizes 300 metric tons and smaller are proof tested to 2 times the Working Load Limit.
- Sizes 400 metric tons and larger are tested to 1.33 time Working Load Limit.
- All ratings are in metric tons, embossed on the side of bow.
- G-2160 (7-55t), are Hot Dip Galvanized and pins are painted red.
- G-2160, (75t and larger), bows are furnished Dimetcoated, and pins are Dimetcoated, then painted red.
- Shackles, 30t and larger, are **RFID EQUIPPED**.
- Greatly improves life of wire rope slings.
- Can be used to connect HIGH STRENGTH Synthetic Web Slings, HIGH STRENGTH Synthetic Round Slings or Wire Rope Slings.
- Increase in shackle bow radius provides minimum 58% gain in sling bearing surface and eliminates need for a thimble.
- Pin is non-rotating, with weld-on handles for easier use (75t and larger).
- Bow and bolt are Certified to meet charpy impact testing of 42 joules (31 ft-lbs.) min. ave. at -20 degree C.
- All 2160 shackles are individually proof tested and magnetic particle inspected. Crosby certification available at time of order.
- Shackles requiring ABS, Lloyds and other certifications are available upon special request and must be specified at time of order.
- Shackles 18t and larger have DNV Type Approval to Rules for Certification of Lifting Appliances, and are produced in accordance with DNV MSA requirements. Databook is provided that includes required documents.



G-2160

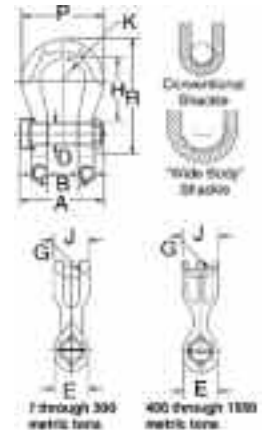

WLL (T)*	G-2160#	Weight	A	B +/- .25	C	D +/- .02	E	G	H	J	K	P	R	Effective Body Dia.
7	1021256	4.0	4.14	1.25	.69	.88	1.82	1.25	3.56	1.60	1.25	4.10	5.87	2.1
12.5	1021265	8.80	5.38	1.69	.92	1.13	2.38	1.37	4.63	2.13	1.63	5.51	7.63	2.4
18	1021274	14.90	6.69	2.03	1.16	1.38	2.69	1.50	5.81	2.50	2.00	6.76	9.38	2.8
30	1021283	26.50	7.69	2.37	1.38	1.63	3.50	1.75	6.94	3.13	2.50	8.50	11.38	4.1
40	1021285	35.00	9.28	2.88	1.69	2.00	4.00	2.31	8.06	3.75	3.00	10.62	13.62	3.6
55	1021287	68.00	10.36	3.25	2.00	2.25	4.63	2.63	9.36	5.00	3.50	12.26	15.63	4.3
†75	1021290	99.00	14.37	4.13	2.12	2.75	5.00	2.50	11.53	4.75	3.64	12.28	18.41	5.9
†125	1021307	161	16.51	5.12	2.56	3.15	5.71	3.15	14.36	5.91	4.33	14.96	22.65	6.8
†200	1021316	370	20.67	5.91	3.35	4.12	7.28	4.33	18.90	8.63	5.41	19.49	29.82	8.9
†300	1021325	847	24.20	7.38	4.00	5.25	9.25	5.38	23.63	10.38	6.31	23.38	37.26	11.8
400	1021334	1130	30.27	8.66	5.16	6.30	11.81	6.30	22.64	12.60	7.28	27.17	38.78	14.3
500	1021343	1440	33.35	9.84	5.73	7.09	13.39	6.69	24.81	13.39	8.86	31.10	42.72	14.8
600	1021352	1995	36.02	10.83	6.23	7.87	15.50	7.28	27.56	14.57	9.74	34.06	47.24	20.3
700	1021361	2415	38.91	11.81	6.59	8.46	14.80	7.87	28.94	15.75	10.63	37.01	50.18	16.6
800	1021254	2880	41.66	12.80	7.30	9.06	16.54	8.27	29.53	16.54	10.92	38.39	52.09	18.0
900	1021389	3628	43.73	13.78	7.78	9.84	16.93	8.66	29.82	17.32	11.52	40.35	54.04	22.4
1000	1021370	4155	45.98	14.96	8.33	10.63	17.72	9.06	29.92	18.11	12.11	42.32	55.31	19.3
1250	1021272	5320	49.86	16.93	9.15	11.81	21.00	10.43	36.61	20.87	12.70	46.26	65.35	24.4
1550	1021281	8302	54.89	18.31	10.58	12.60	23.82	15.92	42.32	22.82	13.29	49.41	73.43	27.3

* Note: Maximum Proof Load is 2.0 times the Working Load Limit. Minimum Ultimate Load is 4 times the Working Load Limit on 200 thru 400 metric tons. For sizes 30 thru 175 metric tons, Minimum Ultimate Load is 5.4 times the Working Load Limit.
** Cast Alloy Steel.
† Furnished with Round Head Bolts with an eyebolt for handling

Alloy Bolt Type Anchor Shackle - Crosby® G-2140/S-2140

- Quenched and Tempered.
- Alloy bows, Alloy bolts.
- Forged Alloy Steel 30 thru 175 metric tons. Cast Alloy Steel 200 thru 400 metric tons.
- Working Load Limit is permanently shown on every shackle.
- Pins are galvanized and painted red.
- All sizes are **RFID EQUIPPED**.
- Shackles are Quenched and Tempered and can meet DNV impact requirements of 43 joules (31 ft-lbs.) at -20 degree C (-4 degree F).
- All sizes are individually proof tested to 2.0 times the Working Load Limit.
- Shackles 200 metric tons and larger are provided as follows:
 - Serialized Pin and Bow
 - Material Certification (Chemical)
 - Magnetic Particle Inspected.
 - Certification must be requested at time of order.
- Meets or exceeds all requirements of ASME B30.26 including identification, ductility, design factor, proof load and temperature performance requirements including fatigue life, impact properties and material traceability, not addressed by ASME B30.26.
- Type Approval and certification in accordance with ABS 2006 Steel Vessel Rules 1-1-17.7, and ABS Guide for Certification of Cranes.



G-2140 & S-2140

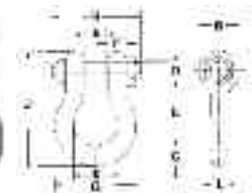

Nominal Shackle Size (in.)	Working Load Limit (t)*	Stock no		Weight Each (lbs.)	Dimensions (in)											Tolerance +/-	
		G-2140	S-2140		A	B	C	D	E	F	G	H	J	K	L	A	E
1-1/2	30	1021110	1021129	18.8	2.38	3.62	1.62	1.63	5.75	1.39	6.88	7.73	10.00	3.88	1.53	.13	.25
1-3/4	40	1021138	1021147	33.8	2.88	4.19	2.25	2.00	7.00	1.75	8.81	9.33	12.34	5.00	1.84	.13	.25
2	55	1021156	1021165	49.9	3.25	4.81	2.40	2.25	7.75	2.00	10.16	10.41	13.68	5.75	2.08	.13	.25
2-1/2	85	1021174	1021183	103	4.12	5.81	3.12	2.75	10.50	2.62	12.75	13.58	17.90	7.25	2.71	.25	.25
3	120	1021192	-	162	5.00	6.50	3.63	3.25	13.00	3.0	14.62	15.13	21.50	7.88	3.12	.25	.25
3-1/2	†150	1021218	-	268	5.25	8.00	4.38	3.75	14.63	3.75	17.02	17.62	24.88	9.00	3.62	.25	.25
4	†175	1021236	-	332	5.50	9.00	4.56	4.25	14.50	4.00	18.00	20.37	25.68	10.00	4.00	.25	.25
4-3/4**	†200	1021414	-	455	7.25	10.50	6.00	4.75	15.63	3.75	21.00	21.21	29.25	11.00	4.50	.25	.25
5**	†250	1021432	-	650	8.50	12.00	6.50	5.00	20.00	3.88	24.50	22.68	35.00	13.00	4.50	.25	.25
6	†300	1021450	-	780	8.38	12.00	6.75	6.00	19.50	4.75	25.0	25.06	35.25	13.00	5.00	.25	.25
7**	†400	1021478	-	120	8.25	14.00	7.25	7.00	22.50	6.50	26.00	28.68	40.25	13.00	6.00	.25	.25



*Note: Maximum Proof Load is 2.0 times the Working Load Limit. Minimum Ultimate Load is 4 times the Working Load Limit on 200 thru 400 metric tons. For sizes 30 thru 175 metric tons, Minimum Ultimate Load is 5.4 times the Working Load Limit.
** Cast Alloy Steel.
† Furnished with the round head bolts with an eyebolt for handling.

Rigging Fittings

Shackles

Euro Ground Release Shackle

For Fast, Safe Lift & Release

The Euro GRS has been developed specially for steel sheet piling. Its purpose is to enable steel piles to be lifted into position, and when held securely in temporary guides, the shackle can be released quickly and safely. It avoids the cost delay and inherent hazards of putting a man up to the release position.

Advantages:

- 1) Fast Hook Up: Shackles straight on to the lifting hole.
 - 2) Fast Release: Release time takes approx. 10 seconds.
 - 3) Safety Feature: An additional 'security' ring provides duplicate safety against accidental release.
 - 4) Safety Checker: Shackle pin is extended through the back of the barrel assembly as an 'indicator bar' This gives a tell-tale indication of the pin position.
- Stiff web section gives high strength/weight ratio on the steel casting.
 - Top ring provides two dimensional flexible joint.
 - Mechanism is enclosed for maximum protection against site conditions.
 - Minimum components for reliability and ease of maintenance.

Quality Assurance:

- Body – high quality alloy steel casting. Inspection procedures:
 - 20% batch x-ray
 - 100% ultrasonic inspection
 - 100% MPI
- Shear shackles are independently proof loaded to twice safe working load certified.
- Prototype shackles tested to five times safe working load.





Type 150 / 4.0, 7.5, 10 Tons

Type	Dim. (in)			SWL (ton)	Wt. (lbs)
	A	B	C		
150/4.0T	6	1.18	0.87	4.4	18
150/7.5T	6	1.18	1.10	8.2	40
150/10T	6	1.18	1.38	11	40

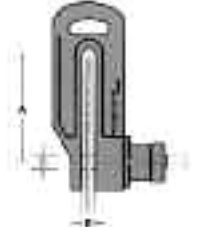

Type 250 / 7.5, 10 Tons

Type	Dim. (in)			SWL (ton)	Wt. (lbs)
	A	B	C		
250/7.5T	10	1.18	1.10	8.2	48
250/10T	10	1.18	1.38	11	48

Note: Pile must fill throat depth – hole in pile should suit Dimension 'A'

LIFTING PAIRS OF PILES

When lifting sheet piles in pairs it is necessary to use a pair of shackles. We supply pairs of shackles mounted on a two legged steel wire rope sling. The advantage being that the standard pair of shackles with lifting sling can be fitted to any pair of Larssen piles where the lifting hole centers are different with every change of width and depth of section. No additional parts or change of components is necessary.



The ring at the top of the sling can be hooked directly onto a standard crane hook block, D shackle or fork anchor. The sling also enables the shackles to be turned to fit opposite faces of box or tube piles using the standard sling and shackles. Shackles can also be fitted onto a solid steel cross head according to customers requirements.

SAFE
Lifting off a stack at 90° to the axis of the pile

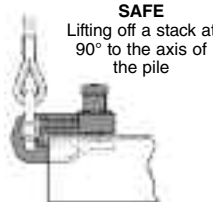

SAFE
Axial loading



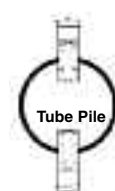

Tube Pile



All 'Z' Profiles



All 'Larssen' Profiles

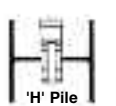

'H' Pile

INSTALLATION:

At all times keep fingers **out** of the Shackle throat.

With the pin in the retracted position (i.e. indicator bar protruding) slide the throat of the Shackle over the top of the sheet pile. Align the Shackle pin over the lifting hole. When you are ready to insert the pin, strike the indicator bar. This action should release the retaining mechanism and project the pin through the lifting hole. The indicator bar should be flush with the barrel. No part of it should protrude. Do not lift the pile if the bar is protruding.

With the pin properly inserted, place the safety ring (the largest diameter ring) over the barrel assembly. This should ensure that no pull on the release wire can be achieved without removing the ring first. Now lay out the release rope along the pile so that it does not become snagged during lifting. You are ready to lift.

At this stage it is good practice for all personnel to stand clear and not turn their backs to the lifting operation (it may be a legal requirement). When the pile is in the vertical position the release rope should be secured (e.g. to the Pile Threader). The pile can now be pitched.

Note: Hole position must suit the "A" dimension on the enclosed charts.

Release:

When the pile is correctly positioned the safety ring should first be released. This is done by whipping the release rope away from the pile. The safety ring should come off the barrel assembly. If it does not come off first time, then repeat until it does. A firm pull on the release rope should then retract the pin. The locking mechanism will hold it in the retracted position. This is confirmed by the indicator bar protruding from the barrel assembly. Release is now complete and ready for the next lift.

Dawson Sheet Pile Threader

To complete the "feet on the ground" approach to sheet piling we offer the Dawson Sheet Pile Threader. This is a mechanical device which interlocks sheet piles when sheet piles are being pitched in panels. It replaces the "Top Man" or "Pile Monkey" who normally carries out the interlocking by hand.



The one basic threader is standard for ALL "Z" section piles, ALL straight web piles and "U" piles above size No. 1. Below this size the "Mini" Pile Threader is available.

Sheet Pile Shackles

- All Alloy No. 59

Specifically designed for pulling sheet piling. They are equipped with an easy opening pin which will not detach and become lost. No tools are required.

Size (in)	Opening (in)	Dimensions (in)								Wt. (lbs)	SWL1 (tons)
		A	B	C	D	E	F	G	H		
1	1-3/4	4-1/4	2-1/4	1	1-1/8	7 ± 1/4	5/8	2-3/8	5	8	8
1-1/8	2	4-1/2	2-1/2	1	1-1/4	8 ± 1/2	3/4	3	5	13	10
1-1/4	2-1/4	5-1/4	2-3/4	1-1/4	1-3/8	9 ± 1/2	7/8	3	5	18	12
1-1/2	2-1/2	6-1/4	3	1-5/8	1-5/8	10 ± 1/2	1-1/8	3-1/2	6	28	17
1-3/4	3	7	3-1/2	1-3/4	2	11 ± 1/2	1-1/4	4	7	47	24
2	3-1/2	8	4	2	2-1/4	12 ± 3/4	1-3/8	4-1/2	8	63	30



Shackles

“Synthetic Sling Saver” Shackles - Crosby® S-252 & S-253

- Shackles available in size 3-1/4 to 50 metric tons.
- All Alloy construction.
- Design factor of 5 to 1.
- Each shackle has a Product Identification Code (PIC) for material traceability along with a Working Load Limit and the name Crosby forged into it.
- Increased radius of bow gives wider sling bearing surface resulting in an increased area for load distribution, thus:
 - Increasing Synthetic Sling efficiency as compared to standard anchor and chain shackle bows and conventional hooks. This allows 100% of the slings rated Working Load Limit to be achieved.
 - Allows better load distribution on internal fibers.

- Shackles available in both a Screw Pin and Bolt, Nut and cotter pin configuration.
- Meets or exceeds all requirements of ASME B30.26 including identification, ductility, design factor, proof load and temperature requirements. Importantly, these shackles meet other critical performance requirements including fatigue life, impact properties and material traceability, not addressed by ASME B30.26.
- Bolt (Pin) has a larger diameter that provides better load distribution.



S-252 (Bolt Type)

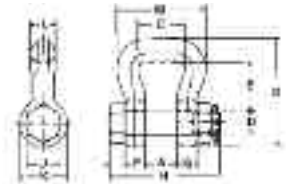

S-252 Bolt Type Sling Shackle

Web Sling Eye Width	Round Sling Size (No.)	Working Load Limit (t)*	S-252 Stock No.	Weight Each (lbs.)	Dimensions (in.)												
					A	B	C	D	E	F	G	H	J	K	L	M	
1	1 & 2	3-1/4	1020485	1.4	1.06	.58	1.38	.75	1.50	.44	3.38	3.68	1.12	1.50	.75	2.69	
1.5	3 & 4	6-1/2	1020496	2.4	1.25	.75	1.75	.88	1.88	.50	4.15	4.25	1.31	1.81	1.00	3.38	
2	5 & 6	8-3/4	1020507	4.1	1.38	.88	2.25	1.00	2.81	.56	5.50	4.72	1.50	2.09	1.12	4.19	
3	7 & 8	12-1/2	1020518	8.0	1.62	1.12	3.25	1.25	3.06	.75	6.34	5.88	1.88	2.62	1.38	5.62	
4	9 & 10	20-1/2	1020529	16.9	2.12	1.38	4.50	1.50	5.25	.88	9.45	7.19	2.25	3.12	1.75	7.50	
5	11 & 12	35	1020540	35.0	2.50	1.75	5.50	2.00	6.34	1.12	11.50	9.31	3.00	4.19	2.25	9.19	
6	13	50	1020551	57.5	3.00	2.12	6.50	2.25	7.70	1.25	13.75	10.38	3.38	4.75	2.75	11.00	

S-253 Screw Pin Sling Shackle

Web Sling Eye Width	Round Sling Size (No.)	Working Load Limit (t)*	S-253 Stock No.	Weight Each (lbs.)	Dimensions (in.)												
					A	B	C	D	E	G	K	L	M	N	P	R	
1	1 & 2	3-1/4	1020575	1.4	.88	.62	1.38	.75	1.50	3.38	1.50	.75	2.69	3.22	0.44	1.00	
1.5	3 & 4	6-1/2	1020584	2.2	1.25	.75	1.75	.88	1.88	4.15	1.81	1.00	3.38	4.03	.50	1.19	
2	5 & 6	8-3/4	1020593	3.8	1.38	.88	2.25	1.00	2.81	5.50	2.09	1.12	4.19	4.50	.50	1.44	
3	7 & 8	12-1/2	1020602	7.3	1.62	1.12	3.25	1.25	3.06	6.34	2.62	1.38	5.62	5.59	.62	1.81	
4	9 & 10	20-1/2	1020611	15.2	2.12	1.38	4.50	1.50	5.25	9.45	3.12	1.75	7.50	6.88	.75	2.13	
5	11 & 12	35	1020620	30.8	2.50	1.75	5.50	2.00	6.34	11.50	4.19	2.25	9.19	8.66	1.00	2.88	
6	13	50	1020629	52.0	3.00	2.12	6.50	2.25	7.70	13.75	4.75	2.75	11.00	10.22	1.22	3.19	

S-256 Link Plate

- The “Link Plate” is designed to connect two S-252 or S-253 “Sling Saver” Shackles together.



Working Load Limit (t)*	S-256 Stock No.	Weight Each (lb)	Dimensions (in)				
			A	B	C	D	E
3-1/4	1020785	.83	.75	1.50	3.38	.81	1.88
6-1/2	1020796	1.62	1.00	1.75	4.12	.94	2.25
8-3/4	1020807	2.71	1.25	2.00	4.75	1.06	2.62
12-1/2	1020818	5.18	1.50	2.50	6.00	1.31	3.37
20-1/2	1020829	8.19	1.75	3.00	7.00	1.62	3.75
35	1020840	17.19	2.00	4.00	9.25	2.12	5.00
50	1020851	37.40	2.88	5.00	10.50	2.38	5.75

* Maximum Proof Load is 2.5 times the Working Load Limit. Minimum Ultimate Strength is 5 times the Working Load Limit.

Crosby Sling Saver hardware meets the requirements for minimum stock diameter or thickness, and effective contact width shown in the Recommended Standards Specification for Synthetic Polyester Round Slings by the Web Sling & Tie Down Association. WSTDA-RS1 (revised 2010)



S-253 (Screw Pin)

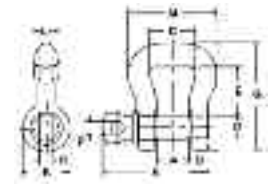

* Maximum Proof Load is 2.5 times the Working Load Limit. Minimum Ultimate Strength is 5 times the Working Load Limit.

Web Sling Shackle Sling Saver® Fittings - Crosby® S-2381

Web Sling Shackle is designed to connect Synthetic Web Slings and Synthetic Round Slings to eyebolts, pad eyes, and lifting lugs.

- All Alloy Construction
- Design Factor of 5 to 1.
- Each shackle has a Product Identification Code (PIC) for material traceability along with a Working Load Limit and the name Crosby forged into it.
- Incorporates same ear spread and pin dimensions as conventional Crosby Shackles. Allows easy connection to pad eyes, eye bolts, and lifting lugs.

- Increased radius of bow gives wider sling bearing surface resulting in an increased area for load distribution, thus:
 - Increasing Synthetic Sling efficiency as compared to standard anchor and chain shackle bows and conventional eye hooks. This allows 100% of the slings rated Working Load Limit to be achieved.
 - Allows better load distribution on internal fibers.
- Meet or exceeds all requirement of ASME B30.26 including identification, ductility, design factor, proof load and temperature require-

ments. Importantly, these shackles meet other critical performance requirements including fatigue life, impact properties and material traceability, not addressed by ASME B30.26.



S-2381

Crosby Sling Saver hardware meets the requirements for minimum stock diameter or thickness, and effective contact width shown in the Recommended Standards Specification for Synthetic Polyester Round Slings by the Web Sling & Tie Down Association. WSTDA-RS1 (revised 2010)

Round Sling Size No.	Web Slings*		Ply	S-281 WLL† (tons)	S-281 Stock (No.)	Wt. Each (lbs)	Dimensions (in)						
	Webbing Width (in)	Eye Width (in)					A	C	D	E	K	M	N
1 & 2	2	2	2	3-1/4	1021048	1.2	1.06	2.50	.75	1.62	1.22	3.84	3.34
3	3	1.5	2	4-1/2	1021057	1.5	1.25	2.00	.88	1.50	1.41	3.38	3.97
4	4	2	2	6-1/4	1021066	2.5	1.44	2.50	1.00	2.00	1.62	4.22	4.50
5 & 6	6	3	2	8-1/2	1021075	4.3	1.69	3.62	1.13	2.75	1.84	5.64	5.13

* NOTE: Designed for use with Type III, (Eye & Eye), Class 7, 2 Ply web slings. For 3" and larger webbing width, tapered eye is required. † Maximum Proof Load is 2-1/2 times the Working Load Limit. Minimum Ultimate strength is 5 times the Working Load Limit.

Rigging Fittings

Sling Saver Fittings

High Performance Sling Connector - Crosby® S-237 & S-238

High Performance Sling Connector is designed to connect High Performance Synthetic Slings of all materials.

- Capacities available:
 - Working Load Limit (5 to 1): 5,000 through 60,000 lbs.
 - Sling Body Widths: 2" through 6".
- Allows easy connection to master links or eye hooks, and is ideal for bridles.
- Increased radius of bow gives wider sling bearing surface resulting in an increased area for load distribution, thus:
 - Increasing Synthetic Sling efficiency as compared to master links, shackle bows and conventional eye hooks. This allows 100% of the slings rated Working Load Limit to be achieved.
 - Allows better load distribution on internal fibers.

- All Alloy Construction.
- Design Factor of 5 to 1.
- Individually Proof Tested at 2.5 times the Working Load Limit.
- Each connector has a Product Identification Code (PIC) for material traceability, along with a frame size, and the name Crosby and USA in raised letters.

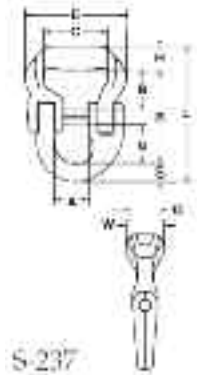

S-237 High Performance Sling Connector

Working Load Limit (lbs)		S-237 Web to Lok-A-Loy Assy. Stock No.	Frame No.	Nominal Sling Body Width (in.)	Lok-A-Loy Size (in.)	Weight Each (lbs.)	Dimensions (in.)												
4:1*	5:1						A	B	C	E	G	H	L	N	R	S	W		
6250	5000	1020695	5	2	3/8	1.14	.88	1.42	2.00	3.18	1.00	.80	4.20	1.04	2.92	.48	1.38		
12500	10000	1020704	10	3	5/8	2.96	1.42	1.52	2.75	4.13	1.25	.98	5.68	1.71	3.94	.75	1.75		
18750	15000	1020713	15	3	3/4	4.75	1.63	1.58	2.75	4.37	1.38	1.10	6.49	2.04	4.46	.93	1.88		
31250	25000	1020722	25	4	7/8	8.59	2.00	2.33	3.75	6.00	1.75	1.41	7.97	2.27	5.51	1.06	2.25		
37500	30000	1020731	30	4	7/8	9.24	2.00	2.20	3.75	6.19	1.75	1.41	7.84	2.27	5.38	1.06	2.38		
50000	40000	1020740	40	5	1	15.7	2.25	2.91	4.75	7.25	2.25	1.78	9.45	2.44	6.45	1.22	3.09		
75000	60000	1020759	60	6	1-1/4	26.0	2.56	3.36	5.75	9.13	2.31	1.86	11.08	3.07	7.72	1.50	3.16		

* Maximum Proof Load is 2 times the Working Load Limit at 4:1 design factor. Minimum Ultimate Strength is 5 times the Working Load Limit.

Crosby Sling Saver hardware meets the requirements for minimum stock diameter or thickness, and effective contact width shown in the Recommended Standards Specification for Synthetic Polyester Round Slings by the Web Sling and Tie Down Association. WSTDA-RS1 (revised 2010)

S-238 High Performance Sling Connector

Working Load Limit (lbs.)	S-238 Web to Web Assembly Stock No.	Frame No.	Nominal Sling Body Width (in.)	Lok-A-Loy Size (in.)	Weight Each (lbs.)	Dimensions (in)									
						A	B	C	E	G	H	K	M	W	
5000	1020415	5	2	3/8	1.6	.88	1.42	2.00	3.18	1.00	.80	4.90	3.30	1.38	
10000	1020423	10	3	5/8	3.3	1.42	1.52	2.75	4.13	1.25	.98	5.72	3.76	1.75	
15000	1020432	15	3	3/4	4.9	1.63	1.58	2.75	4.37	1.38	1.10	6.16	3.96	1.88	
25000	1020441	25	4	7/8	10.1	2.00	2.33	3.75	6.00	1.75	1.41	8.40	5.58	2.25	
30000	1020450	30	4	7/8	11.4	2.00	2.20	3.75	6.19	1.75	1.41	8.14	5.32	2.38	
40000	1020469	40	5	1	20.7	2.25	2.91	4.75	7.25	2.25	1.78	10.48	6.92	3.09	
60000	1020478	60	6	1-1/4	32.0	2.56	3.36	5.75	9.13	2.31	1.86	11.72	8.00	3.16	

* Maximum Proof Load is 2.5 times the Working Load Limit. Minimum Ultimate strength is 5 times the Working Load Limit.

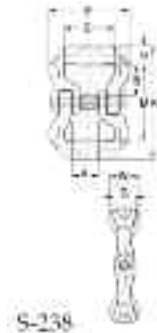

Sling Saver® Fittings - Web Connector - Crosby® S-280

The Web Connector line is designed to connect Synthetic Web Slings and Synthetic Round Slings to conventional hardware.

- Connects Synthetic Web and Synthetic Round Slings to conventional Crosby hardware including:
 - 320N Eye Hook
 - Additional Crosby Grade 8 Fittings
 - Master Links
 - Rings
 - Shackles
- Makes a field assembled bridle quick and easy.
- No cotter pin to snag sling material.
- Durable plastic cover that:
 - Protects sling at eye
 - Keeps slings positioned correctly on spool.

- Increased radius of spool gives wider sling bearing surface resulting in an increased area for load distribution, thus:
 - Increasing Synthetic Sling efficiency by at least 15% as compared to standard anchor and chain shackle bows and conventional eye hooks. This allows 100% of the slings rated Working Load Limit to be achieved.
 - Allowing better load distribution on internal fibers.
- All Alloy construction.
- Design Factor of 5 to 1.
- Replacement kit for spool and web cover available.
- Designed for use with Type III (Eye & Eye), Class 7, 2 ply webbing and Synthetic Round Slings. Also accommodates single ply and endless slings.



S-280 Web Connector

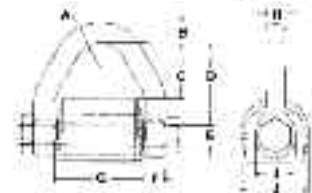

Round Sling Size No.	Web Slings*			S-280 WLL† No.	S-280 Stock No.	Wt. Each (lbs)	Dimensions (in)									
	Webbing Width (in)	Eye Width (tons)	Ply				A	B	C	D	E	F	G	H	I	J
1 & 2	2	2	2	3-1/4	1021681	1.5	.75	.62	1.63	2.44	.63	.62	2.69	.56	1.19	2.02
3	3	1.5	2	4-1/2	1021690	1.9	.75	.69	1.10	2.01	.75	.69	2.19	.60	1.38	2.34
4	4	2	2	6-1/4	1021700	2.9	.75	.81	1.66	2.56	.88	.75	2.69	.69	1.62	2.46
5 & 6	6	3	2	8-1/2	1021709	5.1	1.00	.94	2.47	3.50	1.00	.88	3.69	.88	1.88	2.84

WARNING

- A failing load may cause serious injury or death.
- Read, understand and follow all instructions and chart information before using web connector.
- Before use, tighten bolt first, then tighten nut.

* Type III (Eye & Eye), Class 7, 2 Ply.
† NOTE: Maximum Proof Load is 2-1/2 times the Working Load Limit. Minimum Ultimate strength is 5 times the Working Load Limit.

Sling Saver Fittings/Links

Web/Chain Connector - Crosby® S-282

Designed around the same concept as our S-280 Web Connector, the S-282 Chain Connector makes the connection from your web sling to existing chain quick and easy.

- Available in three sizes:
 - 3-1/4 ton Working Load Limit - 2" Webbing to 3/8" (10mm) chain.
 - 4-1/2 ton Working Load Limit - 1-1/2" (3" Tapered Webbing) to 1/2" (13mm) chain.
 - 6-1/4 ton Working Load Limit - 2" (4" Tapered Webbing) to 5/8" (16mm) chain.
- Each Connector has a Product Identification Code (PIC) for material traceability along with a Working Load Limit and the name Crosby forged into it.
- Uses same spool and cover as the S-280 Web Connector.
 - Replacement Kit for Spool and Web Cover available.

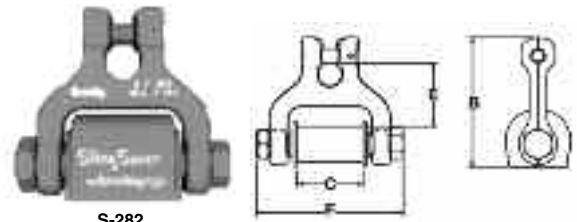

S-282
Chain Connector

Round Sling Size (No.)	Web Slings*			Chain Size	Limit (Tons) †	S-282 Stock No.	Weight Each (lbs.)	Dimensions (in)			
	Webbing Width (in.)	Eye Width	Ply					B	C	E	F
1 & 2	2	2	2	3/8	3-1/4	1021084	1.9	4.33	2.13	2.11	4.77
3	3	1.5	2	1/2	4-1/2	1021093	2.8	5.04	1.63	2.44	4.54
4	4	2	2	5/8	6-1/4	1021100	4.3	5.69	2.13	2.54	5.31

* NOTE: Designed for use with Type III, (Eye & Eye), Class 7, 2 Ply web slings.
†Maximum Proof Load is 2-1/2 times the Working Load Limit. Minimum Ultimate Strength is 4 times the Working Load Limit.

Choker Hook - Crosby® S-287

- Available in 2 sizes: 3-1/4 tons (2" webbing) and 4-1/2 tons (3" webbing).
- Forged Alloy steel – Quenched & Tempered.
- Design factor of 5 to 1.
- Each Connector has a Product Identification Code (PIC) for material traceability along with a Working Load Limit and the name Crosby forged into it.
- Special design of hook protects the synthetic sling when dropped or dragged.
- Designed to reduce friction, abrasion, and fraying in choker area.
- Uses same spool and cover as S-280 Web Connector.
- Replacement Kit for Spool and Web Cover available.

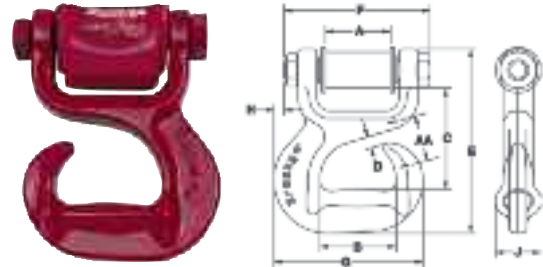

Round Sling Size (No.)	Web Slings*			Working Load Limit (t) †	S-287 Stock No.	Weight Each (lb)	Dimensions (in)									
	Webbing Width (in)	Eye Width (in)	Ply				A	B	C	D	E	F	G	H	J	AA
1 & 2	2	2	2	3-1/4	1021909	3.7	2.13	2.50	3.32	.38	6.03	4.77	4.88	.34	1.50	1.50
3	3	1.5	2	4-1/2	1021918	6.1	1.63	3.50	3.67	.38	7.06	4.53	6.51	1.36	1.88	-

* NOTE: Designed for use with Type III, (Eye & Eye), Class 7, 2 Ply web slings.
†Maximum Proof Load is 2-1/2 times the Working Load Limit. Average straightening load (ultimate load) is 5 times the working load limit.

Master Link/Grade 8 Alloy Fitting - Crosby® A-342

- Alloy Steel – Quenched and Tempered.
- Individually Proof Tested with certification.
- Proof Tested with 60% inside width special fixtures sized to prevent localized point loading per ASTM A-952.
- Meets or exceeds all requirements of ASME B30.26 including identification, ductility, design factor, proof load and temperature requirements. Importantly, these links meet other critical performance requirements including fatigue life, impact properties and material traceability, not addressed by ASME B30.26.
- Forgings have a Product Identification Code (PIC) for material traceability, along with the size, the name Crosby and USA in raised lettering.
- Selected sizes designated with "W" in the size column have enlarged inside dimensions to allow additional room for sling hardware and crane hook.
- Crosby 1-1/4" to 2" 342/345 master links are type approved to DNV Certification Notes 2.7-1- Offshore Containers. These Crosby master links are 100% proof tested, MPI and impact tested. The tests are conducted by Crosby and 3.1 test certification is available upon request.
- Incorporates patented QUIC-CHECK® deformation indicators.

Size		A-342 Stock No.	Weight Each (lbs.)	Working Load Limit (lbs.)*	Proof Load (lbs.)**	Dimensions (in)			
(In.)	(mm)					A	B	C	Deformation Indicator
1/2W	13W	1014266	1.3	7400	17200	.62	2.80	5.00	3.50
5/8	16	1014280	1.5	9000	18000	.62	3.00	6.00	3.50
3/4W	19W	1014285	2.0	12300	28400	.73	3.20	6.00	4.00
7/8W	22W	1014319	3.3	15200	35200	.88	3.75	6.38	4.50
1W	26W	1014331	6.1	26000	60000	1.10	4.30	7.50	5.50
1-1/4W	32W	1014348	12.0	39100	90400	1.33	5.50	9.50	7.00
1-1/2W	38W	1014365	18.6	61100	141200	1.61	5.90	10.50	7.50
1-3/4	44	1014388	25.2	84900	169800	1.75	6.00	12.00	7.50
2	51	1014404	37.0	102600	205200	2.00	7.00	14.00	9.00
2-1/4	57	1014422	54.1	143100	289200	2.25	8.00	16.00	10.00
2-1/2	63	1014468	68.5	160000	320000	2.50	8.38	16.00	11.00
2-3/4	70	1014440	94.0	216900	433800	2.75	9.88	18.00	12.50
3	76	1014486	115	228000	456000	3.00	9.88	18.00	13.00
3-1/4	83	1014501	145	262200	524400	3.25	10.00	20.00	13.50
3-1/2	89	1014529	200	279000	558000	3.50	12.00	24.00	15.50
3-3/4	95	1015051	198	336000	672000	3.75	10.00	20.00	13.50
4	102	1015060	264	373000	746000	4.00	12.00	24.00	16.00
†† 4-1/4	††108	1015067	302	354000	708000	4.25	12.00	24.00	-
†† 4-1/2	††114	1015079	345	360000	72000	4.50	14.00	28.00	-
†† 4-3/4	††121	1015088	436	389000	778000	4.75	14.00	28.00	-
†† 5	††127	1015094	516	395000	790000	5.00	15.00	30.00	-



A-342



* Ultimate Load is 5 times the Working Load Limit. Based on single leg sling (in-line load), or resultant load on multiple legs with an included angle less than or equal to 120 degrees. Applications with wire rope and synthetic sling generally require a design factor of 5. **Proof Test Load equals or exceeds the requirement of ASTM A952(8.1) and ASME B30.9. ††Welded Master Link.

Rigging Fittings

Links

Weldless End Links

- Self Colored or Hot Dip galvanized.
- Forged carbon steel - Quenched and Tempered.

Size A (in)	Stock No. G-340 Galv	S-340 S.C.	WLL* (lbs)	Wt. Each (lbs)	Dim. (in)		
					B	C	D
5/16	1014057	1014066	2500	.15	.50	1.75	1.18
3/8	1014075	1014084	3800	.22	.56	1.88	1.38
1/2	1014093	1014100	6500	.49	.75	2.38	1.81
5/8	1014119	1014128	9300	.97	1.00	3.25	2.32
3/4	1014137	1014146	14000	1.51	1.13	3.50	2.68
7/8	1014155	1014164	12000	2.59	2.00	5.13	3.75
1	1014173	1014182	15200	3.95	2.25	5.75	4.25
1-1/4	1014191	1014208	26400	7.30	2.50	7.00	5.00
1-3/8	1014217	1014226	30000	10.38	2.75	7.75	5.50



G-340 & S-340

*Ultimate load is 5X the working load limit.



Weldless Sling Links

- Self Colored or Hot Dip galvanized.
- Forged carbon steel - Quenched and Tempered.



G-341 & S-341

Size A (in)	Stock No. G-340 Galv	S-340 S.C.	WLL* Single Pull (lbs)	Wt. Each (lbs)	Dimensions (in)					
					B	C	D	E	F	
3/8	1013897	1013904	1800	.23	1.13	.75	3.00	2.25	.38	
1/2	1013913	1013922	2900	.55	1.50	1.00	4.00	3.00	.50	
5/8	1013931	1013940	4200	1.06	1.87	1.25	5.00	3.75	.63	
3/4	1013959	1013968	6000	1.88	2.25	1.50	6.00	4.50	.75	
7/8	1013977	1013986	8300	2.75	2.63	1.75	7.00	5.25	.88	
1	1013995	1014002	10800	4.35	3.00	8.00	6.00	6.00	1.00	
1-1/4	1014011	1014020	16750	7.60	4.00	2.50	10.25	7.50	1.25	
1-3/8	1014039	1014048	20500	11.30	4.13	2.75	11.00	8.25	1.38	

*Ultimate load is 6x the working load limit.

Weldless Rings

- Self Colored.
- Forged carbon steel - Quenched and Tempered.

Size A (in)	Stock No. S-643 Galv	Single Pull WLL* (lbs)	Wt. Each (lbs)	Dim. (in)	
				B	C
7/8 x 4	1013780	7200	2.72	4.00	5.75
7/8 x 5-1/2	1013806	5600	3.47	5.50	7.25
1 x 4	1013824	10800	3.69	4.00	6.00
1-1/8 x 6	1013842	10400	6.60	6.00	8.25
1-1/4 x 5	1013860	17000	6.82	5.00	7.50
1-3/8 x 6	1013888	19000	10.12	6.00	8.75



S-643

*Ultimate load is 6X the working load limit.

Heat Treated & Tempered Alloy Steel Pear-Shaped Links

Stock Dia. (in)	Dimensions (in)			Rated Load Limit (lbs)	Wt. (lbs)	Stock
A	B	C				
1/2	1	2	3	3,800	0.55	ASP-0010
5/8	1-1/4	2-1/2	3-3/4	4,200	1.10	ASP-0020
3/4	1-1/2	3	4-1/2	7,000	1.76	ASP-0030
7/8	1-3/4	3-1/2	5-1/4	14,500	2.82	ASP-0040
1	2	4	6	18,000	4.22	ASP-0050
1-1/8	2-1/4	4-1/2	6-1/2	22,000	6.25	ASP-0060
1-1/4	2-1/2	5	7-1/2	25,000	8.25	ASP-0070
1-3/8	2-3/4	5-1/2	8-1/4	30,000	11.25	ASP-0080
1-1/2	3	6	9	34,000	14.25	ASP-0090
1-5/8	3-1/4	6-1/2	9-3/4	41,000	18.50	ASP-0100
1-3/4	3-1/2	7	10-1/2	46,000	22.50	ASP-0110
1-7/8	3-3/4	7-1/2	11-1/4	55,000	29.00	ASP-0120
2	4	8	12	60,000	34.00	ASP-0130
2-1/4	4-1/2	9	13-1/2	72,000	48.00	ASP-0140
2-1/2	5	10	15	100,000	66.00	ASP-0150
2-3/4	5-1/2	11	16-1/2	130,000	88.00	ASP-0160
3	6	12	18	150,000	114.00	ASP-0170
3-1/4	6-1/2	13	19-1/2	172,000	146.00	ASP-0180
3-1/2	7	14	21	185,000	181.00	ASP-0190
4	8	16	24	250,000	271.00	ASP-0200

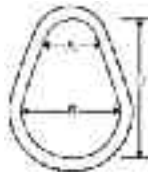

Alloy Steel Rings

Stock Dia. (in.)	W	Rated Load Limit (lbs)	Wt. (lbs)	Stock
3/4	4	5,900	1.90	AR-0780
7/8	4-1/2	9,000	2.90	AR-0790
1	5	11,000	4.40	AR-0800
1-1/4	6	20,000	8.00	AR-0810
1-3/8	6	25,000	10.50	AR-0811
1-1/2	6	30,000	11.80	AR-0820
1-3/4	7	40,000	18.70	AR-0830
2	8	60,000	27.90	AR-0840
2-1/4	9	67,500	39.80	AR-0850
2-1/2	10	83,500	55.00	AR-0851
2-3/4	12	94,000	78.00	AR-0852
3	12	120,000	96.00	AR-0853
3-1/4	12	150,000	113.00	AR-0854
3-1/2	12	185,000	133.00	AR-0855
4	14	237,000	201.00	AR-0856



Basic Machining and Thread Information

- Wrong thread and/or shank size can cause stripping and loss of load.
- The maximum diameter is the largest diameter, after cleanup, that could be expected after allowing for straightness, pits, etc.
- All threads must be Class 2 or better.
- The minimum thread length engaged in the nut should not be less than one (1) thread diameter.
- Hook shanks are not intended to be swaged on wire rope or rod.
- Hook shanks are not intended to be drilled and internally threaded.
- Crosby cannot assume responsibility for, (A) the quality of machining, (B) the type of application, or (C) the means of attachment to the power source or load.
- Consult the Crosby Hook Identification & Working Load Limit Chart (See below) for the minimum thread size for assigned Working Load Limits (WLL).†

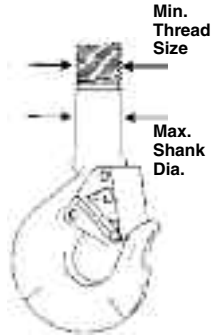

Hook I.D.			WLL (tons) †			Max. Shank Diameter after Machining (in)	Min. Thread Size	
319-C 320-CN 320-C 322-C	319-A 319-AN 320-A 320-AN 322-A	319-BN	319-C 320-CN 322-C	319-A 319-AN 320-A 320-AN 322-A	319-BN		319-C 319-CN (Carbon)	319-A 319-AN (Alloy) 319-BN (Bronze)
DC	DA	DB	.75	1	.5	.53	1/2 - 13 unc	1/2 - 13 unc
FC	FA	FB	1	1.5	.6	.62	5/8 - 11 unc	5/8 - 11 unc
GC	GA	GB	1.5	2	1	.66	5/8 - 11 unc	5/8 - 11 unc
HC	HA	HB	2	3	1.4	.81	3/4 - 10 unc	3/4 - 10 unc
IC	IA	IB	3	*4.5 / 5	2.0	1.03	7/8 - 9 unc	7/8 - 9 unc
JC	JA	JB	5	7	3.5	1.27	1-1/8 - 7 unc	1-1/8 - 7 unc
KC	KA	KB	7.5	11	5.0	1.52	1-1/4 - 7 unc	1-3/8 - 6 unc
LC	LA	LB	10	15	6.5	1.75	1-5/8 - 8 un	1-5/8 - 8 un
NC	NA	NB	15	22	10	2.00	2 - 8 un	2 - 8 un
OC	OA	-	20	30	-	2.50	2-1/4 - 8 un	2-1/4 - 8 un
PC	PA	-	25	37	-	3.50	2-3/4 - 8 un	2-3/4 - 8 un
SC	SA	-	30	45	-	3.50	3 - 8 un	3 - 8 un
TC	TA	-	40	60	-	4.00	3-1/4 - 8 un	3-1/2 - 8 un
UC	UA	-	50	75	-	4.50	3-3/4 - 8 un	4 - 4 unc
-	WA	-	-	100	-	6.12	-	4-1/2 - 8 un
-	XA	-	-	150	-	6.38	-	5-1/2 - 8 un
-	YA	-	-	200	-	7.00	-	6-1/4 - 8 un
-	ZA	-	-	300	-	8.62	-	7-1/2 - 8 un

*319AN and 320-AN are rated at 5 tons

† Working Load Limit - The maximum mass or force which the product is authorized to support in general service when the pull is applied in-line, unless noted otherwise, with respect to the centerline of the product. This term is used interchangeably with the following terms: 1.) WLL 2.) Rated Load Value 3.) SWL 4.) Safe Working Load 5.) Resultant Safe Working Load.

Hooks

Web Sling Hook - Crosby® WS-320A

The Crosby Web Sling hook, originally designed for 2-Ply Web slings, can also be used with Round Slings as long as the Working Load Limit ratings are compatible. This hook incorporates the following features:

- Eye is designed with a wide beam surface which:
 - Eliminates bunching effects.
 - Reduces sling tendency to slide.

- Allows a better load distribution on internal fibers.
- Each hook has a Product Identification Code (PIC) for material traceability along with a working load limit and the name Crosby forged into it. Additionally, all hooks feature Crosby's patented QUIC-CHECK™ indicators.
- Hooks available in sizes 1-1/2, 3, and 5 metric tons.



WS-320 A

Web Sling Nom. Size (in)	Round Sling Size (no)	WLL* (tons)	Hook I.D. Code	WS-320-A S.C.	WSL-320-A w/ Latch	S-4320 Replacement Latch Kit Stock No.
1	1	1-1/2	FA	1022701	1022706	1096374
2	2	3	HA	1022712	1022717	1096468
3	3	5	IA	1022723	1022728	1096515

320 AN - Alloy Steel

Web Sling Nom. Size (in)	Round Sling Size (no)	WLL* (tons)	Dimensions (in)																Wt. Ea. (lbs)	
			A	B	C	D	F	G	H	J	K	L	M	N	O	P	Q	T		AA
1	1	1-1/2	5.25	2.26	3.98	3.11	1.38	.84	.94	.93	.71	1.50	.63	.75	.91	2.24	1.01	.98	2.00	1.10
2	2	3	7.11	3.66	5.31	3.97	1.63	1.13	1.32	1.13	.94	2.50	.85	1.13	1.09	2.82	1.69	1.16	2.00	2.86
3	3	5	9.33	5.13	7.06	4.81	2.00	1.44	1.63	1.47	1.31	3.75	1.13	1.63	1.36	3.51	2.59	1.53	2.50	6.60

Maximum Proof Load is 2-1/2 times the Working Load Limit.
Average straightening load (ultimate load) is 5 times the Working Load Limit.

Eye Hooks - Crosby® S-320 & S-320N

All Crosby 320 Eye Hoist Hooks incorporate the following features:

- The most complete line of Eye hoist hooks.
- Available in carbon steel and alloy steel.
- Designed with a 5:1 Design Factor for (Carbon Steel); 4:1 Design Factor for (Alloy Steel).
- Eye hooks are load rated.
- Proper design, careful forging and precision controlled quenched and tempering give maximum strength without excessive weight and bulk.
- Every Crosby Eye Hook has a pre-drilled cam which can be equipped with a latch. Even years after purchase of the original hook, latch assemblies can be added.
- Chemical analysis and tensile tests performed on each PIC to verify chemistry and mechanical properties.
- Type Approval and certification in accordance with ABS 2006 Steel Vessel Rules 1-1-17.7, and ABS Guide for Certification of Cranes.
- Hoist hooks incorporate two types of strategically placed markings forged into the product which address two (2) QUIC-CHECK® features:
 - Deformation Indicators and Angle Indicators

The following additional features have been incorporated in the new Crosby S-320N Eye Hoist Hooks. (Sizes 3/4 metric ton Carbon through 22 metric ton Alloy.)

- Metric Rated at 5:1 Design Factor for (Carbon Steel); 4:1 Design Factor for (Alloy Steel).
- Can be proof tested to 2 times the Working Load Limit.
- Low profile hook tip.
- New integrated latch (S-4320) meets the World class standard for lifting.
 - Heavy duty stamped latch interlocks with the hook tip.
 - High cycle, long life spring.
 - When secured with the proper cotter pin through the hole in the tip of hook, meets the intent of OSHA Rule 1926.550(g) for personnel hoisting.
- Fatigue rated at 1-1/2 times the Working Load Limit at 20,000 cycles.



S-320N

S-320

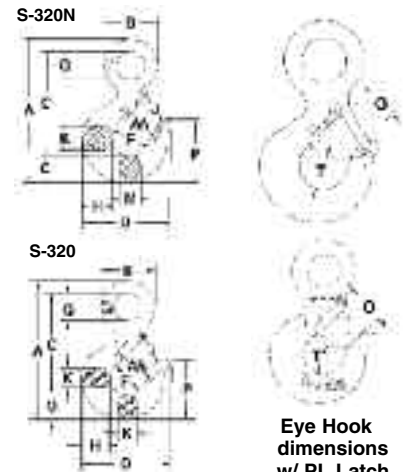

Eye Hook dimensions w/ PL Latch Assembled

WLL (t)*		Hook ID Code	Eye Hook Stock No			Weight Each (lbs)	Replacement Latch Kits		
Carbon	Alloy		Carbon S-320CN S.C.	Carbo G-320CN Galv.	Alloy S-320AN S.C.		S-4320 Stock No.	PL Stock No.	SS-4055 Stock No.
3/4	1	†D	1022200	1022208	1022375	.61	1096325	-	-
1	1-1/2	†F	1022211	1022219	1022386	.89	1096374	-	-
1-1/2	2	†G	1022222	1022230	1022397	1.44	1096421	-	-
2	3	†H	1022233	1022241	1022406	2.07	1096468	-	-
3	5	†I	1022244	1022249	1022419	4.30	1096515	1092000	-
5	7	†J	1022255	1022262	1022430	8.30	1096562	1092001	-
7-1/2	11	†K	1022264	1022274	1022441	15.00	1096609	1092002	-
10	15	†L	1022277	1022285	1022452	20.77	1096657	1092003	-
15	22	†N	1022288	1022296	1022465	39.50	1096704	1092004	-
20	30	O	1023289	-	1023546	60.00	-	1093716	190161
25	37	P	1023305	-	1023564	105.00	-	1093717	1090189
30	45	S	1023323	-	1023582	148.00	-	1093718	1090189
40	60	T	1023341	-	1023608	228.00	-	1093719	1090205

* Eye Hooks (3/4 TC - 22TA), Proof load is 2 times Working Load Limit. Eye Hooks (20 TC - 60TA). All carbon hooks-average straightening load (ultimate load) is 5 times Working Load Limit. Alloy eye hooks 1t through 22t - average straightening load (ultimate load) is 5 times Working Load Limit. Alloy eye hooks 30t through 60t - average straightening load (ultimate load) is 4.5 times Working Load Limit.
† New 320N style hook.

Rigging Fittings

Hooks

S-320 & S-320N Eye Hooks (continued)

Hoist hooks incorporate markings forged into the product which address two QUIC-CHECK® features.

- **Deformation Indicators** - Two strategically placed marks, one just below the shank or eye and the other on the hook tip, which allows for a QUIC-CHECK® measurement to determine if the throat opening has changed, thus indicating abuse or overload. To check, use a measuring device (i.e. tape measure) to measure the distance between the marks. The marks should align to either an inch or half-inch increment on the measuring device. If the measurement does not meet this criteria, the hook should be inspected further for possible damage.
- **Angle Indicators** - Indicates the maximum included angle which is allowed between two (2) sling legs in the hook. These indicators also provide the opportunity to approximate other included angles between two sling legs.

Hook ID*	Dimensions (in)													
	C	D	F	G	J	K	M	N	O†	O2††	Q	T†	T2††	AA
D	3.34	2.83	1.25	.73	.90	.63	.63	.36	.89	—	.75	.87	—	1.50
F	3.81	3.11	1.38	.84	.93	.71	.71	.42	.91	—	.91	.98	—	2.00
G	4.14	3.53	1.50	1.00	1.00	.88	.88	.55	1.00	—	1.13	1.03	—	2.00
H	4.69	3.97	1.63	1.13	1.13	.94	.94	.58	1.09	—	1.25	1.16	—	2.00
I	5.77	4.81	2.00	1.44	1.47	1.31	1.31	.72	1.36	1.00	1.56	1.53	1.50	2.50
J	7.37	6.27	2.50	1.81	1.75	1.66	1.66	.90	1.61	1.31	2.00	1.96	1.88	3.00
K	9.07	7.45	3.00	2.25	2.29	1.88	1.63	1.11	2.08	1.81	2.44	2.47	2.25	4.00
L	10.08	8.30	3.25	2.59	2.50	2.19	1.94	1.27	2.27	2.00	2.84	2.62	2.31	4.00
N	12.53	10.30	4.25	3.00	3.30	2.69	2.38	1.56	3.02	2.75	3.50	2.83	2.56	5.00
O	14.06	13.62	5.00	3.62	4.00	3.00	3.00	1.75	3.25	—	3.50	3.44	—	6.50
P	18.19	14.06	5.38	4.56	4.25	3.75	3.19	2.00	3.00	—	4.50	3.88	—	7.00
S	20.12	15.44	6.00	5.06	4.75	4.50	3.25	2.18	3.38	—	4.94	4.75	—	8.00
T	23.72	18.50	7.00	6.00	5.75	5.50	3.91	2.53	4.12	—	5.69	5.69	—	10.00

*Eye Hooks (3/4 TC-22TA), Proof load is 2 times Working Load Limit. Eye Hooks (20 TC-60TA). All carbon hooks - average straightening load (ultimate load) is 5 times Working Load Limit. Alloy eye hooks 1t through 22t - average straightening load (ultimate load) is 5 times Working Load Limit. Alloy eye hooks 30t through 60t - average straightening load (ultimate load) is 4.5 times Working Load Limit.
 † 3/4TC - 22TA dimensions shown are for S-4320 Latch Kits. Dimensions for sizes 20t carbon and larger are for PL Latch Kits.
 †† Dimensions are for PL-N latch kits.

4
Rigging Fittings

Swivel Hooks - Crosby® S322CN/S322AN

- Forged - Quenched and Tempered.
- Swivel hooks are load rated.
- Proper design, careful forging, and precision controlled quench and tempering gives maximum strength without excessive weight and bulk.
- Low profile hook tip designed to utilize Crosby S-4320 or PL-N latch kit. Even years after purchase of the original hook, latch assemblies can be added.
- Hoist hooks incorporate markings forged into the product which address two (2) QUIC-CHECK® features:
 - Deformation Indicators - Two strategically placed marks, one just below the shank or eye and the other on the hook tip, which allows for a QUIC-CHECK® measurement to determine if the throat opening has changed, thus indicating abuse or overload.
 - Angle Indicators — Indicates the maximum included angle which is allowed between two (2) sling legs in the hook. These indicators also provide the opportunity to approximate other included angles between two sling legs.
- Type Approval and certification in accordance with ABS 2006 Steel Vessel Rules 1-1-17.7, and ABS Guide for Certification of Cranes.

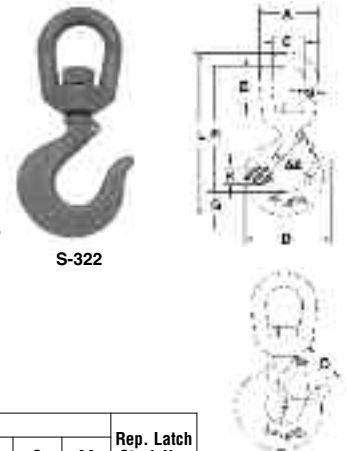

WLL (t)*			Weight Each (lbs.)	Dimensions (in)																Rep. Latch Stock No.
	Carbon	Alloy		A	B	C	D	F	G	H	J	K	L	M	O†	R	S	AA		
4-Mar	1	1048600	1048804	.75	2.00	.82	1.25	2.86	1.25	.73	.81	.93	.63	5.66	.63	.89	4.55	.38	1.50	1096325
1	1-1/2	1048609	1048813	1.25	2.50	1.31	1.50	3.15	1.38	.84	.94	.97	.71	6.71	.71	.91	5.37	.50	2.00	1096374
1/1/2002	2	1048618	1048822	2.25	3.00	1.50	1.75	3.59	1.50	1.00	1.16	1.06	.88	7.75	.88	1.00	6.12	.63	2.00	1096421
2	3	1048627	1048831	2.30	3.00	1.50	1.75	4.00	1.62	1.13	1.31	1.19	.94	8.25	.94	1.09	6.50	.63	2.00	1096468
3	5	1048636	1048837	4.96	3.50	1.64	2.00	4.84	2.00	1.44	1.63	1.50	1.31	9.69	1.13	1.36	7.50	.75	2.50	1096515
5	7	1048645	1048854	10.29	4.56	2.29	2.50	6.28	2.50	1.81	2.06	1.78	1.66	12.47	1.44	1.61	9.63	1.00	3.00	1096562
7/1/2002	11	1048654	1048865	19.40	5.00	2.53	2.75	7.54	3.00	2.25	2.63	2.41	1.88	14.75	1.63	2.08	11.37	1.13	4.00	1096609
10	15	1048663	1048877	23.25	5.62	2.48	3.12	8.34	3.25	2.59	2.94	2.62	2.19	16.40	1.94	2.27	12.25	1.25	4.00	1096657
15	22	1048672	1048886	47.00	7.10	3.76	4.10	10.34	4.25	3.00	3.50	3.41	2.69	21.34	2.38	3.02	16.71	1.50	5.00	1096704
—	30	—	1025688	70.50	7.10	3.76	4.10	13.62	5.00	3.61	4.63	4.00	3.00	23.25	3.00	3.25	18.01	1.50	6.50	1093716

This hook is a positioning device and is not intended to rotate under the load. Use in corrosive environment requires shank and nut inspection in accordance with ASME B30.10-1.10.4 (b)(5)c 2009.

*NOTE: Carbon swivel hooks. 75tC-15tC: proof load is 2 times Working Load Limit. Designed with a 5 to 1 design factor.
 Alloy swivel hooks 11A-221A : proof load is 2.5 times the Working Load Limit. Designed with a 4.5 to 1 design factor.
 Alloy swivel hook 30tA: proof load is 2 times Working Load Limit. Designed with a 4 to 1 design factor.
 † Dimensions for hooks 3/4 ton carbon thru 22t alloy are for S-4320 latch kits. Dimensions for hooks 30t alloy are for PL latch kit.

Hooks

S-322CN & S-322AN Eye Hooks (continued)

WLL (t)*		L-322 CN Stock No.	L-322 AN Stock No.	Weight Each (lbs.)	Dimensions (in)																Rep Latch Stock No.
Carbon	Alloy				A	B	C	D	F	G	H	J	K	L	M	O†	R	S	AA		
3/4	1	1048603	1048807	.75	2.00	.85	1.25	2.86	1.25	.73	.81	.93	.63	5.66	.63	.89	4.55	.38	1.50	1096325	
1	1-1/2	1048612	1048816	1.25	2.50	1.31	1.50	3.15	1.38	.84	.94	.97	.71	6.71	.71	.91	5.37	.50	2.00	1096374	
1-1/2	2	1048621	1048825	2.25	3.00	1.50	1.75	3.59	1.50	1.00	1.16	1.06	.88	7.75	.88	1.00	6.12	.63	2.00	1096421	
2	3	1048630	1048834	2.30	3.00	1.50	1.75	4.00	1.62	1.13	1.31	1.19	.94	8.25	.94	1.09	6.50	.63	2.00	1096468	
3	5	1048639	1048840	4.96	3.50	1.64	2.00	4.84	2.00	1.44	1.63	1.50	1.31	9.69	1.13	1.36	7.50	.75	2.50	1096515	
5	7	1048648	1048859	10.29	4.56	2.29	2.50	6.28	2.50	1.81	2.06	1.78	1.66	12.47	1.44	1.61	9.63	1.00	3.00	1096562	
7-1/2	11	1048657	1048868	19.40	5.00	2.53	2.75	7.54	3.00	2.25	2.63	2.41	1.88	14.75	1.63	2.08	11.37	1.13	4.00	1096609	
10	15	1048666	1048880	23.25	5.62	2.48	3.12	8.34	3.25	2.59	2.94	2.62	2.19	16.40	1.94	2.27	12.25	1.25	4.00	1096657	
15	22	1048675	1048889	47.00	7.10	3.76	4.10	10.34	4.25	3.00	3.50	3.41	2.69	21.34	2.38	3.02	16.71	1.50	5.00	1096704	
-	30	-	-	70.50	7.10	3.76	4.10	13.62	5.00	3.61	4.63	4.00	3.00	23.25	3.00	3.25	18.01	1.50	6.50	1093716	

*NOTE: Carbon swivel hooks. 75°C-15°C: proof load is 2 times Working Load Limit. Designed with a 5 to 1 design factor.
Alloy swivel hooks 1A-22A : proof load is 2.5 times the Working Load Limit. Designed with a 4.5 to 1 design factor.
Alloy swivel hook 30A: proof load is 2 times Working Load Limit. Designed with a 4 to 1 design factor.
† Dimensions for hooks 3/4 ton carbon thru 22t alloy are for S-4320 latch kits. Dimensions for hooks 30t alloy are for PL latch kit.

Swivel Hooks with Bearing - Crosby® S-3322B

New anti-friction bearing design allows hook to rotate freely under load.

- Capacities ranging from 2 through 15 metric tons.
- Forged - Quenched and Tempered.
- Proper design, careful forging, and precision controlled quench and tempering gives maximum strength without excessive weight.
- Low profile hook tip designed to utilize Crosby S-4320 or PL-N latch kit. Even years after purchase of the original hook, latch assemblies can be added.
- S-3322 hooks incorporate markings forged into the product which address two (2) QUIC-CHECK® features:
- Deformation Indicators — Two strategically placed marks, one just below the shank or eye and the other on the hook tip, which allows for a QUIC-CHECK® measurement to determine if the throat opening has changed, thus indicating abuse or overload.
- Angle Indicators — Indicates the maximum included angle which is allowed between two (2) sling legs in the hook. These indicators also provide the opportunity to approximate other included angles between two sling legs.
- Use in corrosive environment requires shank and nut inspection in accordance with ASME B30.10-1.10.4(b)(5)c 2009.
- U.S. Patents 5,381,650 & 5,193,480 & 5,103,755 and foreign equivalents.



WLL (t)*	S-3322 Stock No.	L-3322 Stock No.†	Each (lbs.)	Dimensions (in)																Rep Latch Stock No.
				A	B	C	D	F	G	H	J	K	L	M	O	R	S	AA		
2	1028605	1028609	2.5	3.00	1.50	1.75	3.59	1.50	1.00	1.16	1.06	.88	7.64	.88	1.00	6.01	.63	2.00	1096421	
3	1028614	1028618	3.8	3.50	1.56	2.00	4.00	1.62	1.13	1.31	1.19	.94	8.60	.94	1.09	6.72	.75	2.00	1096468	
5	1028623	1028627	7.0	4.00	1.56	2.25	4.84	2.00	1.44	1.63	1.50	1.31	10.32	1.13	1.36	8.00	.88	2.50	1096515	
7	1028632	1028636	14.0	5.00	1.94	2.75	6.27	2.50	1.81	2.06	1.78	1.66	12.84	1.44	1.61	9.90	1.13	3.00	1096562	
11	1028641	1028645	22.3	5.62	2.05	3.12	7.54	3.00	2.25	2.63	2.41	1.88	15.24	1.63	2.08	11.74	1.25	4.00	1096609	
15	1028650	1028654	36.0	7.12	3.62	4.10	8.33	3.25	2.59	2.94	2.62	2.19	18.64	1.94	2.27	14.41	1.50	4.00	1096657	

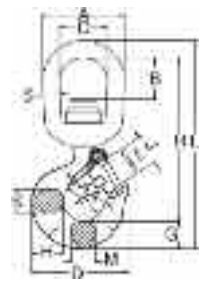

SHUR-LOC® Swivel Hook - Crosby® S-1326/S-13326

- Forged Alloy Steel - Quenched and Tempered.
- Individually Proof Tested at 2-1/2 times the 4:1 Working Load Limit with certification.
- Recessed trigger design is flush with the hook body, protecting the trigger from potential damage.
- Easy to operate with enlarged thumb access.
- Positive Lock Latch is Self-Locking when hook is loaded.
- Rated for both Wire Rope and use with Grade 80/100 Chain.
- G-414 Heavy Thimble should be used with wire rope slings.
- Trigger repair Kit available (S-4316). Consists of spring, roll pin and trigger.
- S-13326 Swivel Hook utilizes anti-friction bearing design which allows hook to rotate freely under load.
- Fatigue rated.
- The SHUR-LOC® hook, if properly installed and locked, can be used for personnel lifting applications and meets the intent of OSHA Rule 1926.1431(g)(1)(i)(A) and 1926.1501(g)(4)(iv)(B).
- "Look for the Platinum Color – Crosby Grade 100 Alloy Products".
- U.S. Patent 5,381,650 and foreign equivalents.

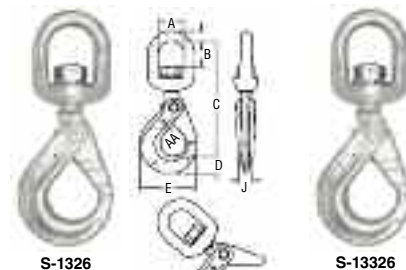

S-1326A Shur-Loc® Swivel Hooks - Suitable for infrequent, non-continuous rotation under load.

Chain Size		S-1326 Stock No.	Grade 100 Alloy Chain WLL (lb) 4:1*	Wire Rope XXIWRC Mechanical Splice		Weight Each (lb)	Dimensions (in)									
(in.)	(mm)			Size (in)	Grade 100 Alloy Chain WLL (lb) 5:1*		A	B	C	D	E	F	H	J	L	AA
	6	1004304	3200	5/16	2200	1.26	1.50	1.32	6.13	.79	2.60	.67	.50	.63	1.13	1.50
1/4-5/16	7-8	1004313	5700	7/16	4200	2.62	1.75	1.59	7.60	1.10	3.50	.87	.63	.81	1.38	2.00
3/8	10	1004322	8800	1/2	5600	4.70	2.00	1.73	8.83	1.17	4.39	1.10	.75	.94	1.75	2.50
1/2	13	1004331	15000	5/8	8600	8.64	2.50	2.38	11.20	1.67	5.45	1.26	1.00	1.16	2.11	3.00
5/8	16	1004340	22600	7/8	16600	17.00	2.75	2.53	12.98	2.05	6.56	1.50	1.13	1.50	2.49	3.50
3/4	18-20	1004349	35300	1	22000	24.00	2.83	2.52	17.42	2.22	7.76	2.01	1.10	2.03	3.52	5.00
7/8	22	1004358	44100	1-1/8	26500	29.00	3.44	3.19	16.47	2.45	8.75	2.26	1.30	2.20	3.83	6.00

* Ultimate Load is 4 times the Working Load Limit.

Rigging Fittings

Hooks

S-13326 Shur-Loc Swivel Hooks (continued)

S-13326 Shur-Loc® Swivel Hooks - Suitable for frequent rotation under load.

Chain Size		S-1326 Stock No	Grade 100 Alloy Chain WLL (lb) 4:1*	Wire Rope XXIP IWRC Mechanical Splice		Weight Each (lb)	Dimensions (in)									
(in.)	(mm)			Size (in)	Grade 100 Alloy Chain WLL (lb) 5:1*		A	B	C	D	E	F	H	J	L	AA
	6	1004304	3200	5/16	2200	1.26	1.50	1.32	6.13	.79	2.60	.67	.50	.63	1.13	1.50
1/4-5/16	7-8	1004313	5700	7/16	4200	2.62	1.75	1.59	7.60	1.10	3.50	.87	.63	.81	1.38	2.00
3/8	10	1004322	8800	1/2	5600	4.70	2.00	1.73	8.83	1.17	4.39	1.10	.75	.94	1.75	2.50
1/2	13	1004331	15000	5/8	8600	8.64	2.50	2.38	11.20	1.67	5.45	1.26	1.00	1.16	2.11	3.00
5/8	16	1004340	22600	7/8	16600	17.00	2.75	2.53	12.98	2.05	6.56	1.50	1.13	1.50	2.49	3.50

* Ultimate Load is 4 times the Working Load Limit..

Grade 100 SHUR-LOC® Hooks - Crosby® S-1316/S-1317

- Forged Alloy Steel - Quenched and Tempered.
- 25% stronger than Grade 80.
- Individually Proof Tested to 2-1/2 times the Working Load Limit with certification.
- Recessed trigger design is flush with the hook body, protecting the trigger from potential damage.
 - Easy to operate with enlarged thumb access.
- Positive Lock Latch is Self-Locking when hook is loaded.
- Eye style is designed with "Engineered Flat" to connect to S-1325 chain coupler.
- Suitable for use with Grade 100 and Grade 80 chain.
- The SHUR-LOC® hook, if properly installed and locked, can be used for personnel lifting applications and meets the intent of OSHA Rule 1926.550 (g) (4) (iv) (B).
- Fatigue rated at 1-1/2 times the Working Load Limit at 20,000 cycles.



S-1316

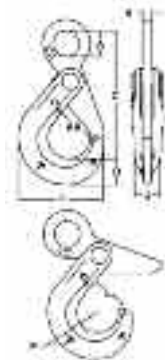

S-1316 Eye Hook

Chain Size		WLL Limit (lbs.)*	S-1316 Stock No.	Weight Each (lbs.)	Dimensions (in)									
(in)	(mm)				A	C	D	E	F	H	J	L	AA	
-	6	3200	122896	.85	.78	3.95	.79	2.60	.67	.31	.63	1.14	1.50	
1/4-5/16	7-8	5700	1022914	1.80	1.08	5.31	1.10	3.50	.87	.39	.81	1.48	2.00	
3/8	10	8800	1022923	3.40	1.30	6.57	1.17	4.39	1.10	.51	.94	1.83	2.50	
1/2	13	15000	1022932	6.00	1.65	8.23	1.67	5.45	1.26	.67	1.16	2.22	3.00	
5/8	16	22600	1022941	15.1	2.20	10.06	2.04	6.56	1.50	.87	1.50	2.65	3.50	
3/4	18-20	35300	1022942	19.0	2.60	10.77	2.22	7.76	2.01	.87	2.03	3.52	-	
7/8	22	42700	1022943	28.0	2.87	12.49	2.45	8.75	2.27	.98	2.20	3.83	-	
1	26	59700	1022944	49.5	3.15	14.60	3.21	9.87	2.46	1.26	2.68	4.09	-	

* Ultimate Load is 4 times the Working Load Limit.

S-1317 Clevis Hook

Chain Size		WLL Limit (lbs.)*	S-1316 Stock No.	Weight Each (lbs.)	Dimensions (in)									
(in)	(mm)				C	D	E	G	J	L	AA			
-	6	3200	1028991	.77	3.44	.79	2.60	4.75	.63	1.16	1.50			
1/4	7	4300	1029000	1.80	4.48	1.10	3.51	6.25	.81	1.48	2.00			
5/16	8	5700	1029009	1.80	4.47	1.10	3.51	6.25	.81	1.48	2.00			
3/8	10	8800	1029018	3.66	5.53	1.17	4.39	7.54	.94	1.83	2.50			
1/2	13	15000	1029027	6.80	6.81	1.67	5.49	9.52	1.16	2.22	3.00			
5/8	16	22600	1029036	11.9	8.22	2.04	6.55	11.61	1.50	2.65	3.50			
3/4	18-20	35300	1029071	15.00	9.42	2.22	7.76	13.21	2.03	3.52	-			
7/8	22	42700	129080	28.0	11.14	2.45	8.75	15.45	2.20	3.83	-			
1	26	59700	1029089	49.5	12.56	3.21	9.87	18.44	2.68	4.09	-			

* Ultimate Load is 4 times the Working Load Limit.



S-1317

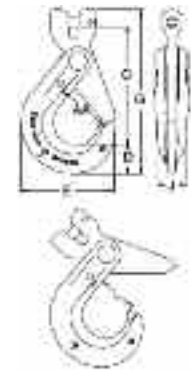

Grade 100 Eye Sling Hooks - Crosby® S-1327

- Forged Alloy Steel - Quenched and Tempered.
- Each hook has a Product Identification Code (PIC) for material traceability, along with the size and the name Crosby & U.S.A. in raised letters.
- 25% stronger than Grade 80.
- Engineered Flat for use with S-1325A coupler link.
- Eye Sling hooks incorporate two types of strategically placed markings forged into the product which address two (2) QUIC-CHECK® features: Deformation Indicators and Angle Indicators.
- Low profile hook tip.
- Utilizes S-4320 integrated latch which meets the world standard for lifting.
- Heavy duty stamped latch interlocks with the hook tip.
- High cycle, long life spring.
- When secured with the proper cotter pin through the hole in the tip of hook, meets the intent of OSHA Rule 1926.1431(g) and 1926.1501(g) for personnel lifting.
- Individually Proof Tested to 2-1/2 times the Working Load Limit with certification.
- Suitable for use with Grade 100 and Grade 80 chain.
- Fatigue rated at 1-1/2 times the Working Load Limit at 20,000 cycles.

S-1327

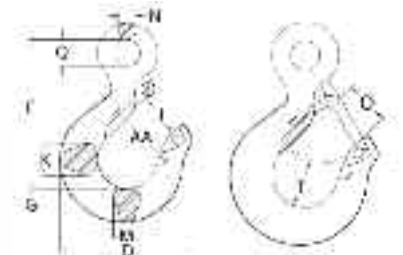

Hooks

S-1327 Eye Sling Hook (continued)

Grade 100 Alloy Chain Size		Working Load Limit (lbs.)*	Hook ID Code	S-1327 Stock No.	L-1327 Stock No.	Weight Each (lbs.)	Dimensions (in.)										Replacement Latch Stock No.	
(in.)	(mm)						C	D	G	J	K	M	N	O	Q	T		AA
-	6	3200	DA	1025857	1025860	.50	3.34	2.86	.73	.90	.63	.63	.36	.89	.75	.87	1.50	1096325
1/4-5/16	7-8	5700	HA	1025866	1025869	1.3	4.21	3.90	1.03	1.18	.75	.75	.50	1.15	.75	1.16	2.00	1096468
3/8	10	8800	IA	1025875	1025878	2.3	4.99	4.34	1.19	1.53	1.19	1.00	.56	1.40	.94	1.23	2.50	1096515
1/2	13	15000	JA	1025884	1025887	4.5	6.36	5.67	1.44	1.78	1.37	1.17	.72	1.67	1.12	1.88	3.00	1096562
5/8	16	22600	KA	1025893	1025896	8.4	7.43	6.78	1.88	2.38	1.66	1.44	.88	2.21	1.31	2.03	4.00	1096609
3/4	18-20	35300	K	1025911	-	15.0	9.07	7.45	2.25	2.29	1.88	1.63	1.11	2.08	2.44	2.47	4.00	1096609
7/8	22-23	44100	L	1025920	-	20.7	10.08	8.30	2.59	2.50	2.19	1.94	1.27	2.27	2.84	2.62	4.00	1096657
1	26	59700	N	1025929	-	39.5	12.82	10.30	3.00	3.30	2.69	2.38	1.56	3.02	3.50	2.83	5.00	1096704
1 1/4	32	90400	P	1025938	-	105.0	18.19	14.06	4.56	4.25	3.75	3.19	2.00	3.00	4.50	3.88	7.00	1093717

* Ultimate Load is 4 times the Working Load Limit.

Grade 100 Clevis Hooks - Crosby® A-1339

- Forged Alloy Steel - Quenched and Tempered.
- Individually Proof Tested to 2-1/2 times the Working Load Limit with certification.
- Each hook has a Product Identification Code (PIC) for material traceability, along with the size and the name Crosby & U.S.A. in raised letters.
- Hoist hooks incorporate two types of strategically placed markings forged into the product which address two (2) QUIC-CHECK® features: Deformation Indicators and Angle Indicators.
- Low profile hook tip.
- New integrated latch (S-4320/S-4339) meets the world standard for lifting.
- Heavy duty stamped latch interlocks with the hook tip.
- High cycle, long life spring.
- When secured with the proper cotter pin through the hole in the tip of hook, meets the intent of OSHA Rule 1926.1431(g) and 1926.1501(g) for personnel lifting.
- Suitable for use with Grade 100 and Grade 80 chain.



A-1339

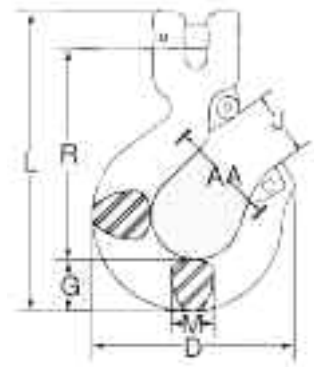

Chain Size		Working Load Limit (lbs.)*	Hook ID Code	A-1339 Stock No.	L-1339 Stock No.	Weight Each (lbs.)	Dimensions (in.)							S-4320 Repl. Latch Stock No.	S-4339 Repl. Latch Stock No.
(in.)	(mm)						D	G	J	L	M	R	AA		
-	6	3200	DA	1048982	1049103	0.64	2.86	0.73	0.93	4.21	0.63	2.95	1.50	1096325	-
1/4	7	4300	HA	1048991	1049112	1.58	3.86	1.04	1.19	5.67	0.75	3.97	2.00	1096468	-
5/16	8	5700	HA	1049000	1049121	1.57	3.86	1.04	1.19	5.67	0.75	3.95	2.00	1096468	-
3/8	10	8800	IA	1049009	1049130	2.58	4.38	1.19	1.53	6.75	1.00	4.71	2.50	1096515	-
1/2	13	15000	JA	1049018	1049149	5.28	5.60	1.44	1.78	8.38	1.17	5.89	3.00	1096562	-
5/8	16	22600	KA	1049027	1049158	9.81	6.76	1.89	2.41	10.21	1.44	6.97	4.00	1096609	-
3/4	18-20	35300	-	1049036	1049167	18.3	8.31	2.83	2.69	13.07	1.97	8.00	4.50	-	1048714
7/8**	22-23**	44100	-	1049045	1049176	24.6	9.17	3.07	3.05	13.98	1.97	8.76	5.00	-	1048732

*Ultimate Load is 4 times the Working Load Limit
 **7/8 in. (22-23 mm) size does not have cam, latch attaches to unique pin.

Grade 100 Clevis Foundry Hooks - Crosby® A-1359

- Forged Alloy Steel - Quenched and Tempered.
- Individually Proof Tested to 2-1/2 times the Working Load Limit with certification.
- Each hook has a Product Identification Code (PIC) for material traceability, along with the size and the name Crosby & U.S.A. in raised letters.
- Hoist hooks incorporate two types of strategically placed markings forged into the product which address two (2) QUIC-CHECK® features: Deformation Indicators and Angle Indicators.
- Low profile hook tip.
- New integrated latch (S-4320/S-4339) meets the world standard for lifting.
- Heavy duty stamped latch interlocks with the hook tip.
- High cycle, long life spring.
- When secured with the proper cotter pin through the hole in the tip of hook, meets the intent of OSHA Rule 1926.1431(g) and 1926.1501(g) for personnel lifting.
- Suitable for use with Grade 100 and Grade 80 chain.
- Fatigue rated at 1-1/2 times the Working Load Limit at 20,000 cycles.



A-1359

Chain Size		A-1359 Stock No.	Working Load Limit at Saddle of Hook (lbs.)*	Working Load Limit at Tip of Hook (lbs.)*	Weight Each (lbs.)	Dimensions (in.)							
(in.)	(mm)					A	C	D	F	G	K	N	AA
1/4	7	1049907	4300	2150	2.10	6.26	4.39	4.82	2.50	1.13	0.88	1.57	3.50
5/16	8	1049911	5700	2850	2.10	6.26	4.37	4.82	2.50	1.13	0.88	1.57	3.50
3/8	10	1049916	8800	4400	4.29	7.76	5.54	5.82	3.00	1.38	1.30	1.88	4.00
1/2	13	1049925	15000	7500	7.93	9.38	6.67	7.04	3.50	1.63	1.50	2.25	4.50
5/8	16	1049934	22600	11300	14.2	11.25	7.68	8.17	4.00	2.19	1.75	2.53	5.00
3/4	18-20	1049943	35300	17650	24.7	14.43	9.79	9.65	5.00	2.40	2.20	3.39	6.00
7/8	22-23	1049952	44100	22050	43.8	16.25	11.02	11.03	5.51	3.07	2.72	3.74	6.50

*Ultimate Load is 4 times the Working Load Limit

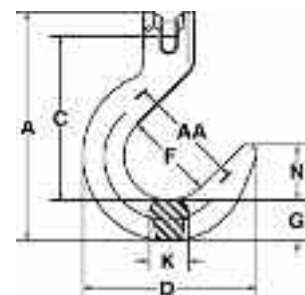

Rigging Fittings

Hooks

Grade 100 Eye Foundry Hooks - Crosby® A-1329

- Forged Alloy Steel - Quenched and Tempered.
- Individually Proof Tested to 2-1/2 times the Working Load Limit with certification.
- Each hook has a Product Identification Code (PIC) for material traceability, along with the size and the name Crosby & U.S.A. in raised letters.
- Suitable for use with Grade 100 and Grade 80 chain.
- Fatigue rated at 1-1/2 times the Working Load Limit at 20,000 cycles.
- Hook can be tip loaded at the reduced Working Load Limit, see below. Operator must ensure the load is retained properly in the hook.

A-1329



Chain Size		A-1329 Stock No.	Working Load Limit at Saddle of Hook (lbs.) *	Working Load Limit at Tip of Hook (lbs.)	Weight Each (lbs.)	Dimensions (in.)							
(in.)	(mm)					B	D	I	K	L	M	N	O
1/4	7	1026280	4300	2150	2.40	1.56	4.75	1.00	1.56	.63	4.75	2.50	1.23
3/8	10	1026289	8800	4400	4.50	2.00	5.69	1.27	1.88	.75	5.75	3.00	1.50
1/2	13	1026297	15000	7500	7.10	2.50	6.75	1.50	2.22	1.00	6.88	3.50	1.75
5/8	16	1026306	22600	11300	12.20	3.00	7.81	1.81	2.63	1.25	8.06	4.00	2.03
3/4	19	1026315	35300	17650	19.30	3.50	9.13	2.20	3.50	1.50	9.25	4.50	2.56
7/8	22-23	1026324	44100	22050	26.30	4.00	10.06	2.25	3.38	1.75	10.38	5.00	2.78

*Ultimate Load is 4 times the Working Load Limit

Grade 100 Cradle Grab Hook - Crosby® A/L-1338

- Forged Alloy Steel - Quenched and Tempered. L-1338
- Innovative cradle design allows for 100% efficiency of Grade 100 chain.
- Individually Proof Tested to 2-1/2 times the Working Load Limit with certification.
- Each hook has a Product Identification Code (PIC) for material traceability, along with the size and the name Crosby & U.S.A. in raised letters.
- Suitable for use with Grade 100 and Grade 80 chain.
- The use of A-1338 Cradle Grab Hook will allow 100 percent of the chain sling capacity. When used to hook back to chain leg to form a choker, the angle of the choke must be 120 degrees or greater.
- Fatigue rated at 1-1/2 times the Working Load Limit at 20,000 cycles.

A-1338

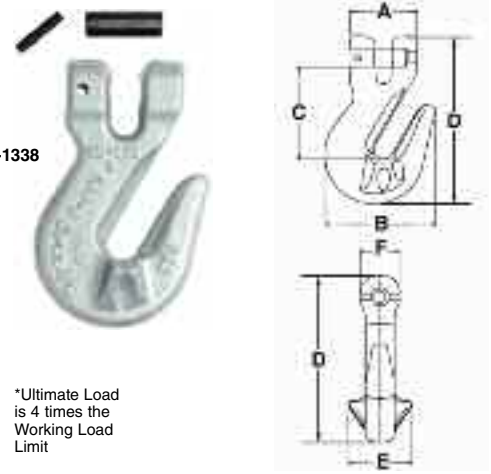

Chain Size		Working Load Limit (lbs.)*	A-1338 Stock No.	L-1338 Stock No.	Weight Each (lbs.)	Dimensions (in.)						S4338 Replacement Latch Kit Stock No.
(in.)	(mm)					A	B	C	D	E	F	
1/4	7	4300	1049417	1049480	.45	1.72	2.54	2.20	3.88	1.50	.88	1048426
5/16	8	5700	1049426	1049489	.99	1.72	2.54	2.18	3.88	1.50	.88	1048426
3/8	10	8800	1049435	1049498	1.80	1.85	3.09	2.58	4.69	1.83	1.09	1048435
1/2	13	15000	1049444	1049507	3.92	2.39	3.83	3.28	5.88	2.25	1.42	1048444
5/8	16	22600	1049453	1049516	7.00	2.67	4.52	3.85	7.03	2.94	1.75	1048453

*Ultimate Load is 4 times the Working Load Limit

Grade 100 Grab Hook - Crosby® A/L-1358

- Forged Alloy Steel - Quenched and Tempered.
- Individually Proof Tested to 2-1/2 times the Working Load Limit with certification.
- Each hook has a Product Identification Code (PIC) for material traceability, along with the size and the name Crosby & U.S.A. in raised letters.
- Suitable for use with Grade 100 and Grade 80 chain.
- Fatigue rated at 1-1/2 times the Working Load Limit at 20,000 cycles.

A-1358

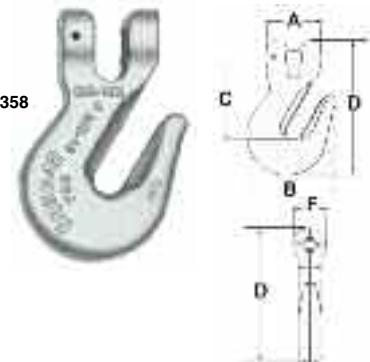

Chain Size		Working Load Limit (lbs.)*	A-1358 Stock No.	L-1358 Stock No.	Weight Each (lbs.)	Dimensions (in.)						S4338 Replacement Latch Kit Stock No.
(in.)	(mm)					A	B	C	D	E	F	
1/4	7	4300	1049610	1049605	.45	1.72	2.54	2.20	3.88	1.50	.88	1048426
5/16	8	5700	1049629	1049614	.99	1.72	2.54	2.18	3.88	1.50	.88	1048426
3/8	10	8800	1049638	1049623	1.80	1.85	3.09	2.58	4.69	1.83	1.09	1048435
1/2	13	15000	1049647	1049634	3.92	2.39	3.83	3.28	5.88	2.25	1.42	1048444
5/8	16	22600	1049656	1049643	7.00	2.67	4.52	3.85	7.03	2.94	1.75	1048453

*Ultimate Load is 4 times the Working Load Limit

Grade 100 Eye Grab Hook - Crosby® A-1328

- Forged Alloy Steel - Quenched and Tempered.
- Individually Proof Tested to 2-1/2 times the Working Load Limit with certification.
- Each hook has a Product Identification Code (PIC) for material traceability, along with the size and the name Crosby & U.S.A. in raised letters.
- Suitable for use with Grade 100 and Grade 80 chain.
- Fatigue rated at 1-1/2 times the Working Load Limit at 20,000 cycles

A-1328



Chain Size		Working Load Limit (lbs.)*	A-1328 Stock No.	Weight Each (lbs.)	Dimensions (in.)							
(in.)	(mm)				A	B	C	E	F	H		
1/4-5/16	7-8	5700	1026169	0.98	1.75	0.75	2.79	4.29	2.57	0.44		
3/8	10	8800	1026187	1.6	2.06	0.94	3.33	5.13	3.09	0.53		
1/2	13	15000	1026196	3.3	2.56	1.12	4.11	6.38	3.83	0.66		
5/8	16	22600	1026205	6	3.07	1.31	4.91	7.62	4.53	0.79		
3/4	18-20	35300	1026214	10.0	3.25	1.50	5.41	8.76	6.00	0.94		
7/8	22-23	44100	1026223	13.1	3.94	1.81	6.48	10.10	6.53	1.09		
1	26	59700	1026232	18.9	4.44	2.00	7.22	11.45	7.75	1.19		
1 1/4	32	90400	1026241	39.4	5.64	2.38	9.08	14.59	9.50	1.50		

*Minimum Ultimate Load is 4 times the Working Load Limit

Hooks

Grade 100 Chain Fittings - Crosby® S-1325A

- Designed to connect Grade 100 chain fittings produced with "Engineered Flat" to Grade 100 chain.
- Forged Alloy Steel - Quenched and Tempered.
- Suitable for use with Grade 100 and Grade 80 chain.
- Individually Proof Tested to 2-1/2 times the Working Load Limit with certification.
- Locking system that provides for simple assembly and disassembly – no special tools required.



Chain Size		S-1325A Stock No.	Working Load Limit (lbs.)*	Weight Each (lbs.)	Dimensions (in.)		
(in.)	(mm)				C	F	G
-	6	1098496	3200	.25	1.03	.74	1.74
1/4	7	1098500	4300	.50	1.41	.88	2.32
5/16	8	1098504	5700	.50	1.40	.88	2.32
3/8	10	1098508	8800	.80	1.84	1.18	2.72
1/2	13	1098512	15000	1.70	2.12	1.50	3.62
5/8	16	1098516	22600	1.90	2.84	1.96	4.40

*Minimum Ultimate Load is 4 times the Working Load Limit

Grade 100 Chain Shortening Link - Crosby® S-1311N

- Alloy Steel - Quenched and Tempered.
- Individually Proof Tested to 2-1/2 times the Working Load Limit with certification.
- Suitable for use with Grade 100 and Grade 80 chain.
- Spring loaded chain locking system keeps chain in place under slack conditions.
- The use of S-1311 Chain Shortener will allow 100 percent of the chain sling capacity.
- Fatigue rated at 1-1/2 times the Working Load Limit at 20,000 cycles.

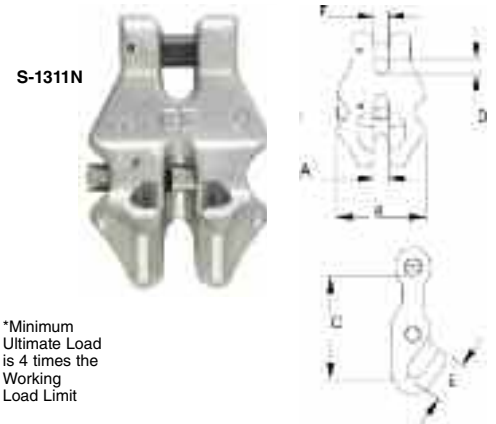

Chain Size		S-1311N Stock No.	Working Load Limit (lbs.)*	Weight Each (lbs.)	Dimensions (in.)					
(in.)	(mm)				A	B	C	D	E	F
-	6	1017860	3200	.49	.30	1.76	1.83	.29	.76	.29
1/4	7	1017869	4300	.84	.34	2.04	2.17	.34	.88	.33
5-16	8	1017878	5700	1.22	.40	2.36	2.53	.39	1.01	.38
3/8	10	1017897	8800	2.03	.48	2.84	3.07	.48	1.23	.46
1/2	13	1017906	15000	4.31	.62	3.56	3.77	.61	1.57	.59
5/8	16	1017915	22600	7.20	.73	4.24	4.64	.73	1.91	.70

*Minimum Ultimate Load is 4 times the Working Load Limit

Grade 100 Chain Choker Hook - Crosby® A-1355

- Forged Alloy Steel - Quenched and Tempered.
- Individually Proof Tested with certification.
- Rated for Grade 100 chain in choker applications.
- Each hook has a Product Identification Code (PIC) for material traceability, along with the size and the name Crosby & U.S.A. in raised letters.
- 25% stronger than Grade 80.
- Fatigue rated at 1-1/2 times the Working Load Limit at 20,000 cycles.
- For use with S-1325 Chain Coupler Link.

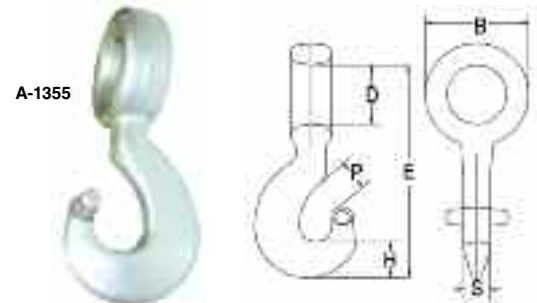

Grade 100 Alloy Chain Size		Working Load Limit (lbs.)*	A-1355 Stock No.	Weight Each (lbs.)	Dimensions (in.)					
(in.)	(mm)				B	D	E	H	P	S
1/4-5/16	7-8	5700	1015204	.77	2.05	1.18	4.83	.79	.69	.65
3/8	10	8800	1015213	1.65	2.66	1.57	6.07	.93	.69	.69
1/2	13	15000	1015222	3.14	3.35	2.03	7.61	1.18	1.26	.94
5/8	16	22600	1015231	6.97	4.21	2.52	9.68	1.54	1.12	1.18

*Ultimate Load is 4 times the Working Load Limit

Rigging Fittings

Hooks

Hoist Shank Hooks - Crosby® S-319

- The most complete line of shank hoist hooks. Available 3/4 to 300 tons.
- Available in carbon steel, alloy steel, and bronze.
- Quenched and Tempered.
- Proper design, careful forging, and precision controlled quench and tempering give maximum strength without excessive weight and bulk.
- Every Crosby Shank Hook has a pre-drilled cam which can be equipped with a latch. Even years after purchase of the original hook, latch assemblies can be added.
- Load Rating code stamped on each hook.
- Includes 2 QUICK-CHECK® features:
 1) Deformation Indicators 2) Angle Indicators

* NOTE: Proof load is 2x Working Load Limit. All carbon hooks - average straightening load (ultimate load) is 5x Working Load Limit. Alloy eye hooks 1 ton through 22 ton - average straightening load (ultimate load) is 5x Working Load Limit. Alloy eye hooks 30 tons through 60 tons - average straightening load (ultimate load) is 4.5x Working Load Limit. All Alloy shank hooks - average straightening load (ultimate load) is 4.3x the Working Load Limit. All Bronze hooks - average straightening load (ultimate load) is 4x Working Load Limit.

WLL* (tons)			Hook I.D. Code			Shank Hooks Stock No.			** Shank Length Type	Wt. Ea. (lbs.)
Carbon	Alloy	Bronze	319-C 319CN 320-C 320CN 322-C	319-A 319AN 320-A 320AN 322-A	319-BN	Carbon S-319-C S-319CN S.C.	Alloy S-319-A S-319AN S.C.	Bronze S-319-B S.C.		
3/4	1	.5	DC	DA	DB	1028505†	1028701†	1028900†	Std.	.50
1	1-1/2	.6	FC	FA	FB	1028514†	1028710†	1028909†	Std.	.75
1-1/2	2	1	GC	GA	GB	1028523†	1028723†	1028918†	Std.	1.00
2	3	1.4	HC	HA	HB	1028532†	1028732†	1028927†	Std.	1.82
3	5	2	IC	IA	IB	1028541†	1028741†	1028936†	Std.	3.69
5	7	3-1/2	JC	JA	JB	1028550†	1028750†	1028945†	Std.	7.25
7-1/2	11	5	KC	KA	KB	1028563†	1028765†	1028954†	Std.	13.49
10	15	6-1/2	LC	LA	LB	1028572†	1028774†	1028963†	Std.	18.00
15	22	10	NC	NA	NB	1028581†	1028783†	1028972†	Std.	35.33
20	30	-	OC	OA	-	1024386	1024803	-	Std.	72.00
20	30	-	OC	OA	-	1024402	1024821	-	Long	85.50
25	37	-	PC	PA	-	1024420	1024849	-	Std.	134.00
25	37	-	PC	PA	-	1024448	1024867	-	Long	172.00
30	45	-	SC	SA	-	1024466	1024885	-	Std.	182.00
30	45	-	SC	SA	-	1024484	1024901	-	Long	214.00
40	60	-	TC	TA	-	1024509	1024929	-	Std.	268.00
40	60	-	TC	TA	-	1024545	1024965	-	Long	312.00
50	75	-	UC	UA	-	1024563	1024983	-	Std.	390.00
50	75	-	UC	UA	-	1024581	1025009	-	Long	426.00
-	100	-	-	WA	-	-	1025027	-	Std.	610.00
-	100	-	-	WA	-	-	1025045	-	Long	675.00
-	150	-	-	XA	-	-	1025063	-	Std.	735.00
-	200	-	-	YA	-	-	1025081	-	Std.	1020.00
-	300	-	-	ZA	-	-	1025090	-	Std.	1390.00

**See column "Y" for actual length. † New 319N Style Hook.
 Hook I. D. Codes: A - Alloy Steel, B - Bronze High Strength, C - Carbon Steel.

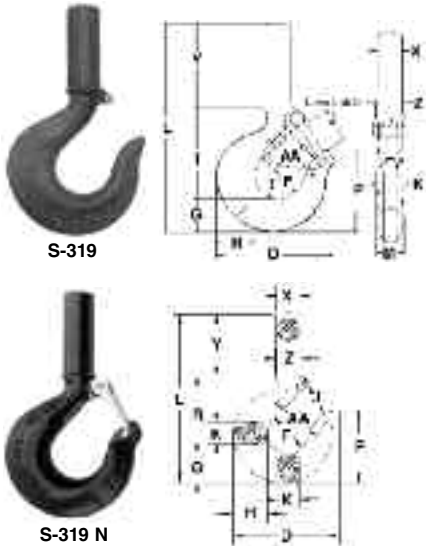

Hook I.D. Code	Dimensions (in)													Deformation Indicator AA		
	D	F	G	H	J	K	L	M	O	P	R	T	X††		Y	Z
D	2.86	1.25	.73	.81	.93	.63	5.14	.63	.93†	1.96	2.35	.97	.59	2.06	.69	1.50
F	3.16	1.38	.84	.94	.97	.71	5.68	.71	.97†	2.22	2.59	.97	.66	2.25	.78	2.00
G	3.59	1.50	1.00	1.16	1.06	.88	6.35	.88	1.06†	2.44	2.76	1.03	.72	2.59	.88	2.00
H	4.00	1.62	1.14	1.31	1.19	.94	7.14	.94	1.16†	2.78	3.16	1.16	.88	2.84	1.00	2.00
I	4.84	2.00	1.44	1.63	1.50	1.31	8.63	1.13	1.41†	3.47	3.85	1.53	1.16	3.34	1.25	2.50
J	6.28	2.50	1.82	2.06	1.78	1.66	10.43	1.44	1.69†	4.59	4.77	1.94	1.41	3.84	1.56	3.00
K	7.54	3.00	2.26	2.63	2.41	1.88	12.52	1.63	2.22†	5.25	5.88	2.46	1.81	4.38	1.94	4.00
L	8.34	3.25	2.60	2.94	2.62	2.19	13.47	1.94	2.41†	5.96	6.37	2.59	2.00	4.50	2.19	4.00
N	10.34	4.25	3.01	3.50	3.41	2.69	16.65	2.38	3.19†	6.88	8.14	2.81	2.56	5.50	2.63	5.00
O	13.62	5.00	3.62	4.62	4.00	3.00	23.09	-	3.25	8.78	9.44	3.44	3.12	10.00	3.12	6.50
P	13.62	5.00	3.62	4.62	4.00	3.00	31.09	-	3.25	8.78	9.44	3.44	3.12	18.00	3.12	6.50
P	14.06	5.38	4.56	5.00	4.25	3.62	32.12	-	3.00	11.38	12.56	3.88	4.00	15.00	4.00	7.00
P	14.06	5.38	4.56	5.00	4.25	3.62	41.12	-	3.00	11.38	12.56	3.88	4.00	24.00	4.00	7.00
S	15.44	6.00	5.06	5.50	4.75	3.72	34.12	-	3.38	12.63	14.00	4.75	4.00	15.00	4.00	8.00
S	15.44	6.00	5.06	5.50	4.75	3.72	43.12	-	3.38	12.63	14.00	4.75	4.00	24.00	4.00	8.00
T	18.50	7.00	6.00	6.50	5.75	4.44	36.06	-	4.12	14.81	15.50	5.69	4.50	14.50	4.50	10.00
T	18.50	7.00	6.00	6.50	5.75	4.44	47.56	-	4.12	14.81	15.50	5.69	4.50	26.00	4.50	10.00
U	20.62	7.75	6.69	7.25	6.50	4.81	41.16	-	5.38	16.53	19.38	6.00	5.00	15.00	5.00	11.50
U	20.62	7.75	6.69	7.25	6.50	4.81	49.16	-	5.38	16.53	19.38	6.00	5.00	23.00	5.00	11.50
W	23.00	6.81	8.59	9.88	5.88	5.50	42.12	-	4.50	17.38	18.41	7.00	7.00	15.00	7.00	12.00
W	23.00	6.81	8.59	9.88	5.88	5.50	48.12	-	4.50	17.38	18.41	7.00	7.00	21.00	7.00	12.00
X	24.38	6.75	9.12	10.94	6.00	6.00	45.75	-	4.50	18.00	18.38	7.00	7.25	18.00	7.25	13.00
Y	26.69	7.50	9.75	11.81	6.60	7.00	50.50	-	5.00	19.25	20.50	8.00	8.00	20.00	8.00	13.00
Z	30.12	9.50	10.62	12.94	8.00	7.25	54.69	-	6.25	22.69	20.50	8.25	9.50	20.00	9.50	15.00

† Dimensions shown are for S-4320 Latch kits. Dimensions for sizes 20 ton carbon and larger are for PL Latch Kits.
 †† Dimension before machining (as forged) - for maximum clean up dimensions after machining

Crosby Custom Machined Shank Hook & Nut Quotation Request Form (Sample):

Customer Name: _____
 Date: _____
 Address: _____
 City, State, Zip: _____
 Phone: _____
 Fax: _____
 Customer Contact Name: _____
 Quotation Due Date: _____
 Product Delivery Date: _____
 Crosby / McKissick Proposal Number: _____
 Quantity: _____

Dimensions:
 Frame Size & Material Symbol _____
 A _____
 B _____
 C* _____
 D _____
 Round or Hex Nut _____
 E _____
 F _____

Hook Latch Kit:
 _____ SS-4055 Flipper Latch
 _____ PL Flapper Latch
 _____ 4320 Latch

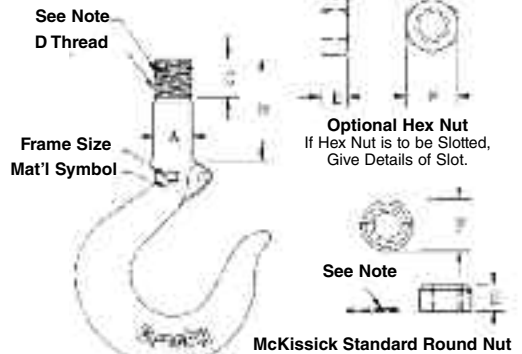

Note: For installation of spring pin, standard practice is to field drill nut and shank after assembly and adjusted take-up is made.

Hooks

Sliding Choker Hooks - Crosby® A-350

- New style incorporates throat opening equal to or larger than old style hooks.
- Each product has a Product Identification Code (PIC) for material traceability, along with a Working Load Limit, and the name Crosby or "CG" forged into it.
- All hooks incorporate Crosby's patented QUIC-CHECK® marks to help in determining if throat opening dimension has changed.
- Each hook can be equipped with a Crosby S-4320 heavy duty stamped latch with the high cycle, long life spring.
- Forged Alloy Steel -- Quenched and Tempered.
- Design Factor of 5 to 1.

A-350



Single Part Rope Size	Eight Part Rope Size (in.)	A-350N Stock No.	Working Load Limit (lbs.)*	Weight Each (lbs.)	Dimensions (in)										Frame Code	Latch Kit Stock No.	
					A	B	C	D	E	F	G	H	L	P			R
3/8	-	1011707	2500	1.0	2.06	1.13	.63	2.41	.63	.38	.84	.91	4.28	2.59	.63	D	1096325
1/2	1/8	1011716	3800	1.4	2.25	1.31	.75	2.97	.78	.50	.97	1.06	4.97	3.09	.75	D	1096325
†5/8	-	1011725	5800	3.0	3.06	1.63	.75	3.56	.94	.56	1.13	1.31	6.38	3.88	1.00	G	1096421
†5/8	3/16	1011734	5800	2.7	3.06	1.63	1.00	3.56	.94	.56	1.13	1.31	6.38	4.00	1.13	G	1096421
†3/4	-	1011743	8200	4.4	3.38	2.13	1.00	4.25	1.16	.63	1.44	1.63	7.66	4.58	1.13	H	1096468
†3/4	1/4	1011752	8200	3.8	3.38	2.13	1.44	4.25	1.16	.63	1.44	1.63	7.66	4.78	1.13	H	1096468
††7/8-1	-	1028177	15000	9.70	4.41	2.12	1.25	6.06	1.41	.88	2.00	2.33	9.55	5.72	1.50	I	1096515

*Ultimate Load is 5 times the Working Load Limit. † Determine EYE diameter "C", before ordering. †† 7/8-1" is Cast Steel & furnished with the latch attached.

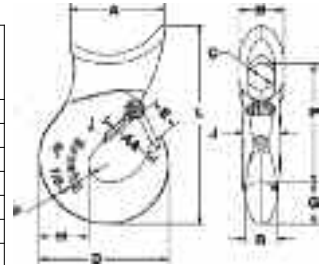

Snap Hooks - Crosby® G-3315

- Forged Carbon Steel -- Quenched and Tempered.
- Pressed steel latches and stainless steel springs, bolts and nuts.
- For replacement latch kit, order Stock No. 9900299.

G-3315

Hook Size	G-3315 Stock No.	WLL (lbs.)*	Weight Each	Dimensions (in)							
				A	B	C	D	E	F	L	R
7/16	1023056	750	.23	.25	.75	.75	.44	2.25	.75	3.94	3.25
9/16	1023074	1000	.48	.34	1.12	.81	.56	2.69	.88	4.75	3.84

*Ultimate Load is 4 times the Working Load Limit

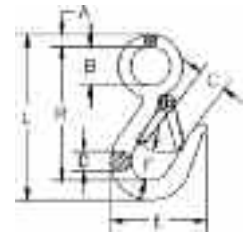

Replacement Hook - Crosby® S-3316

- Easily attaches to any chain and electric hoist with welded link load chain, roller chain or wire rope with suitable end fitting.
- Swivel jaw is forged.
- Suitable for infrequent, non-continuous rotation under load.
- Use in corrosive environment requires shank and nut inspection in accordance with ASME B30.10-1.10.4(b)(5)(c)2009.

S-3316

Working Load Limit (tons)	Frame Code	S-3316 Stock No.	Weight Each (lbs)	Dimensions (in)										Replacement Latch Kit Stock No.
				A	B	C	D	H	L	O	P	R	T	
1/2	F	1023029	1.25	1.31	.76	.56	3.19	.38	6.12	.97	2.25	4.59	.81	1096374
1	H	1023047	2.61	1.56	1.00	.69	4.09	.44	7.69	1.12	2.84	5.81	1.19	1096468

*Ultimate Load is 5 times the Working Load Limit

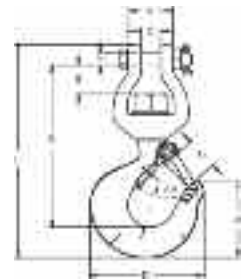

Sorting (Pelican) Hook - Crosby® A-378

- Forged Steel, Quenched and Tempered.
- Deep straight throat permits efficient handling of flat plates or large cylindrical shapes.
- The long tapered point allows easy grab in rings, pear links, eye bolts or lifting holes.

WLL at tip of Hook (tons)*	WLL at bottom of Hook (tons)*	A-378 Stock No.	Style	Weight Each (lbs)	Dimensions (in)			
					I.D. of Eye	Overall Length	Opening at top of Hook	Radius at Bottom of Hook
2	7-1/2	1028024	No handle	6.42	1.38	9.69	2.81	.625
2	7-1/2	1028033	With Handle	6.42	1.38	9.69	2.81	.625



A-378

Barrel Hooks - Crosby® S-377

- Forged Carbon Steel - Quenched and Tempered.
- Meets the performance requirements of Federal Specification RR-C-271F, Type V, Class 6, except for those provisions required of the contractor.

WLL Per Pair (tons)	S-377 Stock No Per Pair	Weight Each Per Pair (lbs)	Dimensions			
			I.D. of Eye	O.D. of Eye	Overall Length	Width of Lip
1	1028248	3.56	1.56	2.81	5.00	2.88



G-377

S-377

Rigging Fittings

Hooks/Latches

Pipe Hooks

- Designed to ease the job of handling pipe.
 - Speeds up loading & unloading of pipe sections, or the moving of pipe when placing pipe into position for connecting or welding.
 - Available in 6 sizes:
- No. 2** - Equipped with soft brass inserts to prevent damaging thin wall gas or oil pipe.
- No. 3** - Same as No. 2 with a longer throat opening. Has brass insert.
- No. 4** - A flame cut 3/4" steel plate hook adaptable for lifting jobs requiring a wide throat opening.
- No. 5** - A wide bearing surface pipe hook with a scuff resistant plastic insert for protecting epoxy lined pipe.
- No. 10** - A versatile multi-purpose pipe hook for lighter lifting jobs
- No. 55** - Same as No.5 with 8-1/2" wide bearing surface and plastic insert.

No.	Rope Size (in)	WLL (lbs)	Wt. (lbs)
2	3/8 - 5/8	8,500	8-1/2
3	3/8 - 5/8	7,500	10-1/2
4	3/8	2,000	5
5	3/8 - 5/8	7,000	13
10	3/8 - 1/2	3,500	7-1/2
55	3/8 - 5/8	7,000	29



Note: Working loads shown in table are based on slings using two pipe hooks.
Warning: The angle of each sling leg should be carefully checked with each usage to prevent overloading.

Release-A-Matic H44 R.A.M. Hook

Benefits & Features:

- Quick disconnect
- Remote release or disengagement
- Place loads where access is restricted
- Saves manpower
- Wide range of angles and release



HOW IT WORKS

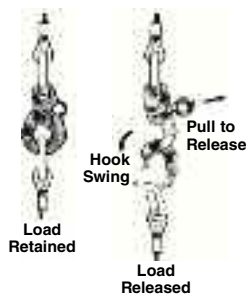

Specifications:

Material: Heat Treated Forged Steel

Finish: Zinc Plated or Cres.

Part No.	Safe Working Load (lbs)	Min. Break Strength (lbs)
H44-3	4,500	18,000
H44-3L	2,000	8,000
H44-9	18,000	71,700

Latch Kit S-4320 - Crosby® Replacement Latch Kit for 319N & 320N Hooks

- Heavy duty stamped latch interlocks with the hook tip.
- High cycle, long life spring.
- Can be made into a "Positive Locking" Hook when proper cotter pin is utilized. **IMPORTANT:** The new S-4320 Latch Kit will not fit the old style 320 and 319 hooks.

Hook Size (tons)		S-4320 Stock No.	Wt. Each (lbs)	Dimensions (in)				
Carbon	Alloy			A	B	C	D	E
3/4	1	1096325	.03	.94	.50	.20	.15	1.44
1	1-1/2	1096374	.04	1.00	.54	.22	.17	1.56
1-1/2	2	1096421	.04	1.09	.63	.23	.17	1.66
2	3	1096468	.06	1.21	.66	.28	.17	1.91
3	5	1096515	.10	1.53	.83	.35	.20	2.31
5	7	1096562	.15	1.88	1.04	.44	.20	2.88
7-1/2	11	1096609	.28	2.38	1.25	.53	.27	3.44
10	15	1096657	.33	2.62	1.35	.59	.27	3.81
15	22	1096704	.84	3.44	1.66	.66	.39	5.18

S-4320
Latch Kits shipped unassembled and individually packaged with instructions.



Heavy Duty Hook Latches PL Latch Positive Locking Flapper Latch

- Heavy duty latch with easy operating features.
 - Hot Dip galvanized.
 - Flapper lever indicates locked or unlocked position.
 - Assembly instructions included with each latch.
 - Meets with the intent of OSHA Rule 1926.550 (g) (when secured with the bolt, nut & pin) for lifting personnel.
- NOTE: The PL latch will not work on 320N Hooks.

Hook Size (tons)		S-4320 Stock No.	Wt. Each (lbs)	Dimensions (in)					
Carbon	Alloy			A	B	C	D	E	F
3	4-1/2	1093711	.54	2.57	2.34	1.94	.56	1.13	2.00
5	7	1093712	.66	3.00	2.34	2.00	.63	1.38	2.22
7-1/2	11	1093713	1.00	3.63	2.77	2.38	.63	1.63	2.38
10	15	1093714	1.25	4.00	3.22	2.69	.63	1.88	3.38
15	22	1093715	2.96	5.31	4.00	2.91	.84	2.38	3.44
20	30	1093716	4.05	6.00	4.44	3.19	1.06	2.88	4.25
25	37	1093717	8.63	7.00	6.63	4.06	2.24	4.50	6.12
30	45	1093718	10.00	6.75	7.00	4.03	2.24	4.75	6.38
40	60	1093719	14.30	8.00	7.66	4.38	3.46	5.50	7.25
50	75	1093720	27.00	9.88	8.19	5.13	3.38	6.50	8.88
-	100-150	1093721	33.25	10.88	11.06	6.38	3.38	7.50	10.00
-	200	1093723	45.00	11.88	11.19	6.38	3.38	8.75	11.25
-	300	1093724	55.00	12.50	12.19	8.00	3.38	9.75	13.00

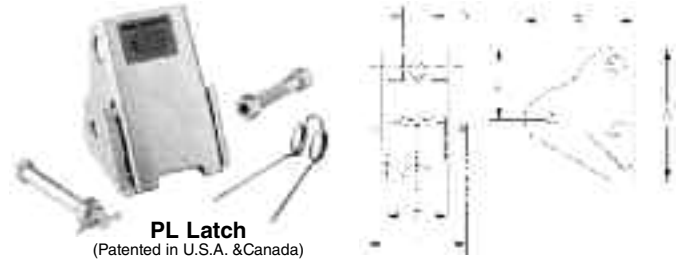

Crosby Latch Kit

- Stainless Steel construction with cadmium plated steel nuts.
- Shipped packaged & unassembled.
- Instructions included for easy field assembly.



Hook Size (tons)			SS-4055 Stock No.	Wt. Each (lbs)	Dimensions (in)			
Carbon	Alloy	Bronze			A	B	C	D
3/4	1	.5	1090027	.02	.38	.16	1.44	.59
1	1-1/2	.6	1090045	.02	.38	.16	1.60	.59
1-1/2 - 2	2 - 3	1.0 - 1.4	1090063	.03	.47	.19	1.84	.82
3	4-1/2	2.0	1090081	.06	.56	.17	2.41	1.00
5	7	3.5	1090107	.11	.58	.20	2.97	1.21
7-1/2 - 10	11 - 15	5.0 - 6.5	1090125	.17	.59	.27	3.66	1.50
15	22	10.0	1090143	.39	.83	.39	4.94	1.90
20	30	-	1090161	.63	.94	.52	5.88	2.56
25 - 30	37 - 45	-	1090189	1.12	2.19	.39	6.50	3.84
40	60	-	1090205	1.77	3.31	.52	7.88	4.12

Note: These latches will not work on 320N Hooks

Alloy Hook Latch Kit - Crosby®

Hook Chain Size (in)	S-4088 Stock No.	Wt. Each (lbs)	Dimensions (in)			
			A	B	C	D
9/32 (1/4)	1090250	.06	.78	.16	2.03	.94
3/8	1090251	.14	1.06	.19	2.62	1.25
1/2	1090252	.15	1.06	.19	2.94	1.25
5/8	1090253	.15	1.06	.19	3.09	1.25
3/4	1090254	.15	1.31	.26	4.12	1.62
7/8	1090255	.15	1.56	.26	4.56	1.75



S-4088
To be used on A-327 & A-339 Grade 8 Sling Hooks

Latch Ordering Instructions:

1. Specify latch kit stock number from chart.
2. Specify capacity of hook to which latch will be assembled.
3. Specify hook material (carbon or alloy).

Assembly Instructions

For SS-4055 Latch onto Crosby Hooks:

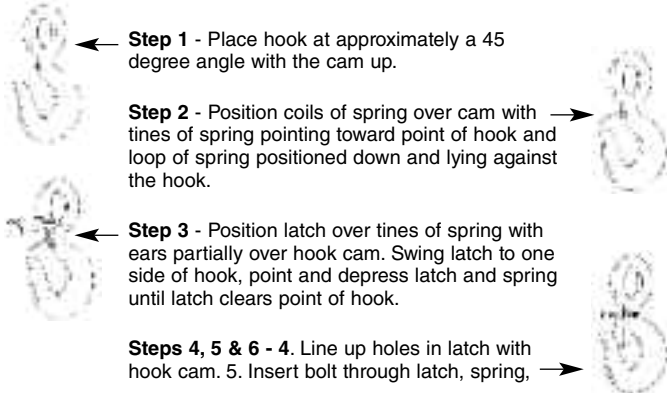

For PL Latch onto Crosby or McKissick Hooks:

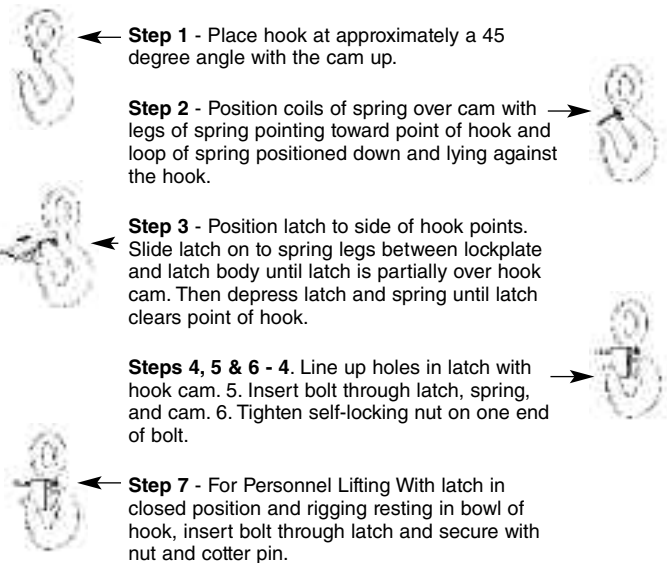

Universal Safety Latch

M Size of Latch	Dim. N (in)	Throat Opening "T" of Hook (in)
A	9/16 - 5/8	1-1/16 - 1-1/8
B	3/4 - 13/16	1-1/4
C	7/8 - 1	1-3/8 - 1-1/2
D	1-1/8 - 1-1/4	1-3/4 - 1-7/8
E	1-3/8 - 1-1/2	2-1/16
F	1-5/8 - 1-11/16	2-1/4
G	1-3/4 - 1-13/16	2-1/2
H	1-7/8 - 2	3
J	2-1/16 - 2-1/8	3-3/8
K	2-3/16 - 2-1/4	3-1/2
L	2-5/16 - 2-3/8	3-3/4
M	2-7/16 - 2-3/4	4
O	3 - 3-1/4	4-1/2

Standard Neck and Throat dim. can be combined. For example, Neck size E can be combined with Throat size L.

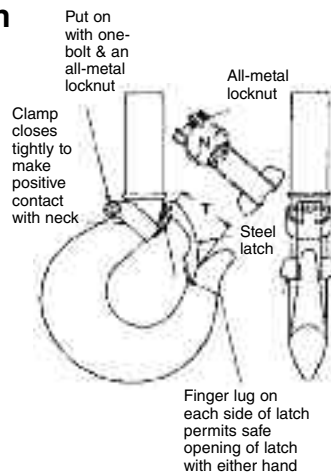

SLING MANUFACTURER & RIGGING SPECIALISTS
 CONTRACTOR & INDUSTRIAL SUPPLIER



Let us help you create solutions for your lifting needs.

Hanes Supply has over 80 years experience splicing wire rope and manufacturing slings. We produce a number of different types of slings including: SlingMax, chain, nylon, and wire rope.

Have a lifting project you need help with? Hanes Supply possesses the experience and expertise to manufacture equipment for your most challenging rigging equipment requirements.

TOLL FREE - 888.426.3755
WWW.HANESSUPPLY.COM

Headquarters • 55 James E Casey Drive • Buffalo, NY 14206 • 716.826.2636
 Rochester 585.235.0160 • Albany 518.438.0139 • Watertown 315.782.8247
 Syracuse 315.299.4114 • North Carolina 704.506.4744
 South Carolina 843.458.0749 • Branford 203.481.3469

Rigging Fittings

Crosby® Golden Gate Hooks®

Safety & Application Instructions

BL-A BL-C | BL-B BL-B | BL-I BL-K

BL-PKU BL-G BL-E | BL-P BL-O | BL-R BL-S

QUIC-CHECK™ Hoist Hooks incorporate markings forged into the product which address two (2) QUIC-CHECK® features:

Deformation Indicators - Two strategically placed marks, one just below the shank or eye and the other on the hook tip, which allows for a QUIC-CHECK® measurement to determine if the throat opening has changed, thus indicating abuse or overload.

To check, use a measuring device (i.e., tape measure) to measure the distance between the marks. The marks should align to either an inch or half-inch increment on the measuring device. If the measurement does not meet criteria, the hook should be inspected further for possible damage.

Angle Indicators - Indicates the maximum included angle which is allowed between two (2) sling legs in the hook. These indicators also provide the opportunity to approximate other included angles between two sling legs.

Important Safety Information

- A visual periodic inspection for cracks, nicks, wear, gouges and deformation as part of a comprehensive documented inspection program, should be conducted by trained personnel in compliance with the schedule in ANSI B30.10.
 - For hooks used in frequent load cycles or pulsating loads, the hook and threads should be periodically inspected by Magnetic Particle or Dye Penetrant. (Note: some disassembly may be required.)
 - See WARNING box and Figure 6 for special instructions for securing the nut to the shank at assembly.
 - Never use a hook whose throat opening has been increased, or whose tip has been bent more than 10 degrees out of plane from the hook body, or is in any other way distorted or bent.
- Note: A gate will not work properly on a hook with a bent or worn tip.**
- Manual - closing gates must be completely closed for the lock to work.
 - Never use a hook that is worn beyond the limits shown in Figure 1.
 - Remove from service any hook with a crack, nick, or gouge. Hooks with a crack, nick, or gouge shall be repaired by grinding lengthwise, following the contour of the hook, provided that the reduced dimension is within the limits shown in Figure 1.
 - Never repair, alter, rework, or reshape a hook by welding, heating, burning, or bending.
 - Never side load, back load, or tip load a hook. (See Figure 2.)

- Eye hooks, shank hooks and swivel hooks are designed to be used with wire rope or chain. Efficiency of assembly may be reduced when used with synthetic material.
 - The use of a latch may be mandatory by regulations or safety codes; e.g., OSHA, MSHA, ANSI/ASME B30, Insurance etc.
 - Always make sure the hook supports the load. (See Figure 3). The gate must never support the load (See Figure 4).
 - When placing two (2) sling legs in hook, make sure the angle from the vertical to the outermost leg is not greater than 45 degrees, and the included angle between the legs does not exceed 90 degrees* (See Figure 5).
 - See ANSI/ASME B30.10 "Hooks!" for additional information.
 - If any of the following conditions exist, remove hook from service immediately and repair with genuine Crosby/Bullard Golden Gate® hook parts or replace the hook.
 - The gate does not lock in the closed position.
 - The gate is worn, deformed, inoperative, or fails to bridge the hook throat opening.
 - Load pins or bolts in the chain connectors are worn or bent.
 - When hook is used to support a hoist, the weight of the hoist must be deducted from the assigned hook Working Load Limit.
 - The rated capacity of chain connector hook assemblies must equal or exceed the capacity of the hoist.
- *For angles greater than 90 degrees, or more than two legs, a master link or bolt type anchor shackle should be used to attach the legs of the sling to the hook.

Fig.1

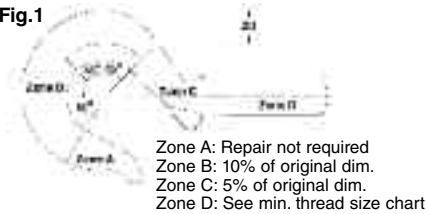

Fig.2

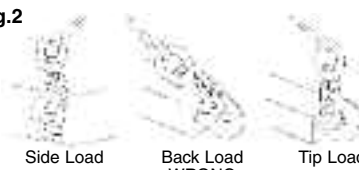

Fig.3



Fig.4



Fig.5



Fig.6

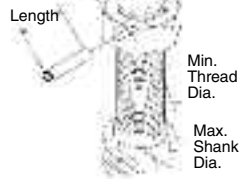

Important - Basic Machining and Thread Information

- Wrong thread and/or shank size can cause stripping and loss of load.
- The maximum diameter is the largest diameter that will fit into the gate.
- All threads must be Class 2 or better.
- The minimum thread length engaged in the nut should not be less than one thread diameter.
- All nuts must be secured to the shank by cross drilling the nut and threaded shank and inserting the appropriate coil type spring pin. (See WARNING box and Figure 6 for special instructions)
- Coil type spring pin must be as long as the distance across the nut flats or diameter (See Figure 6).
- Consult the Crosby / Bullard Golden Gate® Hook Identification and Working Load Limit Chart for the coil type spring pin diameter.
- Remove any hook from service that requires a larger coil type spring than that shown in the chart below.
- Hook shanks are not intended to be swaged on wire rope or rod.
- Hook shanks are not intended to be drilled and internally threaded.
- Crosby cannot assume responsibility for, (A) the quality of machining, (B) the type of application, or (C) the means of attachment to the power source or load.
- Consult the Crosby/ Bullard Golden Gate® Hook Identification & Working Load Limit Chart (See chart below) for the minimum thread size for assigned Working Load Limits(WLL). †
- Remove from service any hook which has threads corroded more than 20% of the nut engaged length.

Crosby/Bullard Golden Gate® Hook Identification & Working Load Limit Chart

Hook/ Gate Size	**† WLL (tons)	Max. Shank Dia. (in)	Min. Thread Size	Spring* Pin Size (in)	Drilled Hole Size (in)	Hook/ Gate Size	WLL (tons)	Max. Shank Dia. (in)	Min. Thread Size	Spring* Pin Size (in)	Drilled Hole Size (in)
1	.5	—	—	—	—	11	9.2	1.497	1-1/2 - 6 UNC	5/16	.308 / .319
2	1.0	.498	1/2 - 13 UNC	1/8	.124 / .129	12	12.3	1.622	1-5/8 - 5-1/2 UNC	5/16	.308 / .319
3	1.4	.559	9/16 - 12 UNC	1/8	.124 / .129	13	15.0	1.747	1-3/4 - 5 UNC	3/8	.370 / .383
4	1.7	.623	5/8 - 11 UNC	1/8	.124 / .129	14	18.5	1.997	2 - 4-1/2 UNC	3/8	.370 / .383
5	2.3	.747	3/4 - 10 UNC	5/32	.155 / .160	16	24.7	2.747	2-3/4 - 4 UNC	1/2	.493 / .510
6	4.0	.872	7/8 - 9 UNC	3/16	.185 / .192	16-A	33.0	2.747	2-3/4 - 4 UNC	1/2	.493 / .510
7	4.2	.997	1 - 8 UNC	3/16	.185 / .192	17	49.5	3.996	4 - 8 UN	3/4	.743 / .760
8	5.5	1.122	1-1/8 - 7 UNC	1/4	.247 / .256	17-A	66.0	3.996	4 - 8 UN	3/4	.743 / .760
9	7.2	1.247	1-1/4 - 7 UNC	1/4	.247 / .256	—	—	—	—	—	—

* Heavy Duty Coil Type Spring Pin.

** Min. ultimate strength is 4x the Working Load Limit.

† Working Load Limit - The maximum mass or force which the product is authorized to support in general service when the pull is applied in-line, unless noted otherwise, with respect to the centerline of the product. This term is used interchangeably with the following terms: 1) WLL 2) Rated Load Value 3) SWL 4) Safe Working Load 5) Resultant Safe Working Load.

Crosby® Golden Gate Hooks®

Closed Swivel Bail

Hook Size & Type	Crosby Stock No.	Bullard Stock No.	Gate Type	WLL* (tons)	Wt. Each (lbs)
BL-C with Self-Closing Gate					
1C	1050210	5161010001	LIF-LOK	0.50	0.8
2C	1050221	5162020300	IN-LOK	1.00	1.3
3C	1050232	5162030300	PIN-LOK	1.40	1.9
4C	1050243	5162040300	PIN-LOK	1.70	2.2
5C	1050254	5164050300	ROLLOX	2.30	3.8
6C	1050265	5164060300	ROLLOX	4.00	4.6
7C	1050276	5164070300	ROLLOX	4.20	6.9
8C	1050287	5164080300	ROLLOX	5.50	9.6
9C	1050298	5164090300	ROLLOX	7.20	13.5
11C	1050309	5163110300	TIP-LOK	9.20	20.5
12C	1050320	5163120300	TIP-LOK	12.30	27.0
14C	1050342	5163140300	TIP-LOK	18.50	55.0
BL-A with Manual Closing Gate					
1A	1050001	-	LIF-LOK	0.50	0.8
2A	1050012	5162020100	PIN-LOK	1.00	1.3
3A	1050023	5162030100	PIN-LOK	1.40	1.9
4A	1050034	5162040100	PIN-LOK	1.70	2.2
5A	1050045	5164050100	ROLLOX	2.30	3.8
6A	1050056	5164060100	ROLLOX	4.00	4.6
7A	1050067	5164070100	ROLLOX	4.20	6.9
8A	1050078	5164080100	ROLLOX	5.50	9.6
9A	1050089	5164090100	ROLLOX	7.20	13.5
11A	1050100	5163110100	TIP-LOK	9.20	20.5
12A	1050111	5163120100	TIP-LOK	12.30	27.0
14A	1050133	5163140100	TIP-LOK	18.50	55.0



BL-C
w/self-closing gate
BL-A
w/manual-closing gate.

For use where hoisting line or shackle can be inserted into the bail.

* Ultimate Load is 4x the Working Load Limit

Standard Length Shank Hook

Hook Size & Type	Crosby Stock No.	Bullard Stock No.	Gate Type	* WLL (lbs)	Wt. Ea. (tons)	Shank Dia. (In)	Shank Dia. (in)
BL-D with Self-Closing Gate							
2D	1050606	5162020400	PIN-LOK	1.00	1.1	.50	.91
3D	1050617	5162030400	PIN-LOK	1.40	1.3	.56	1.16
4D	1050628	5162040400	PIN-LOK	1.70	1.7	.63	1.34
5D	1050639	5164050400	ROLLOX	2.30	2.5	.75	1.38
6D	1050650	5164060400	ROLLOX	4.00	3.5	.88	1.63
7D	1050661	5164070400	ROLLOX	4.20	5.2	1.00	1.94
8D	1050672	5164080400	ROLLOX	5.50	7.1	1.13	2.13
9D	1050683	5164090400	ROLLOX	7.20	9.5	1.25	2.38
11D†	1050694	5163110400	TIP-LOK	9.20	15.6	1.50	2.75
12D†	1050705	-	TIP-LOK	12.30	21.0	1.63	2.88
13D†	1050716	-	TIP-LOK	15.00	30.0	1.75	3.50
14D†	1050727	5163140400	TIP-LOK	18.50	40.0	2.00	3.75
BL-B with Manual Closing Gate							
2B	1050408	5162020200	PIN-LOK	1.00	1.1	.50	.91
3B	1050419	5162030200	PIN-LOK	1.40	1.3	.56	1.16
4B	1050430	5162040200	PIN-LOK	1.70	1.6	.63	1.34
5B	1050441	5164050200	ROLLOX	2.30	2.6	.75	1.38
6B	1050452	5164060200	ROLLOX	4.00	3.6	.88	1.63
7B	1050463	5164070200	ROLLOX	4.20	5.2	1.00	1.94
8B	1050474	5164080200	ROLLOX	5.50	7.1	1.13	2.13
9B	1050485	5164090200	ROLLOX	7.20	9.5	1.25	2.38
11B†	1050496	5163110200	TIP-LOK	9.20	15.6	1.50	2.75
12B†	1050507	5163120200	TIP-LOK	12.30	21.0	1.63	2.88
13B†	1050518	-	TIP-LOK	15.00	30.0	1.75	3.50
14B†	1050529	-	TIP-LOK	18.50	40.0	2.00	3.75



BL-D
w/self-closing gate
BL-B
w/manual-closing gate.

* Ultimate Load Is 4x the Working Load Limit.

† Requires a drawing indicating the hook's exact shank diameter, shank length, thread length and throat opening requirements.

Nos. 2D - 12D & 2B - 12B style hooks are threaded approximately 80% of shank length.

Open Swivel Bail

Hook Size & Type	Crosby Stock No.	Bullard Stock No.	Gate Type	WLL* (tons)	Wt. Each (lbs.)
BL-E with Self-Closing Gate					
3E	1051607	5162030500	PIN-LOK	1.40	1.8
4E	1051618	5162040500	PIN-LOK	1.70	2.1
5E	1051629	5164050500	ROLLOX	2.30	3.2
BL-G with Manual Closing Gate					
3G	1051706	5162030700	PIN-LOK	1.40	1.8
4G	1051717	5162040700	PIN-LOK	1.70	2.1
5G	1051728	5164050700	ROLLOX	2.30	3.2



BL-E
w/self-closing gate
BL-G
w/manual-closing gate.
Open swivel bail for attachment to link chain.

*Ultimate Load is 4x the Working Load Limit

Long Length Shank Hook

Hook Size & Type	Crosby Stock No.	Bullard Stock No.	Gate Type	* WLL (tons)	Wt. Each (tons)	Shank Dia. (In)	Shank Length (in)
BL-K with Self-Closing Gate							
4K-1/2	1051002	5162041000	PIN-LOK	1.60	1.9	.50	3.32
4K-9/16	1051013	-	PIN-LOK	1.70	1.9	.56	3.32
4K-5/8	1051024	-	PIN-LOK	1.70	1.9	.63	3.32
5K	1051035	5164051000	ROLLOX	2.30	3.0	.75	3.55
6K	1051046	5164061000	ROLLOX	4.00	3.8	.88	4.12
7K	1051057	5164071000	ROLLOX	4.20	5.9	1.00	4.75
8K	1051068	5164081000	ROLLOX	5.50	7.8	1.13	5.13
9K	1051079	5164091000	ROLLOX	7.20	10.8	1.25	5.62
11K††	1051090	5163111000	TIP-LOK	9.20	18.6	1.50	AR
12K††	1051101	5163121000	TIP-LOK	12.30	28.0	1.63	5.38
13K††	1051112	-	TIP-LOK	15.00	35.0	1.75	7.38
14K††	1051123	5163141000	TIP-LOK	18.50	45.0	2.00	5.38
16K†	1051134	5163161000	TIP-LOK	33.00	103.0	2.75	16.00
17K†	1051156	5163171000	TIP-LOK	66.00	370.0	4.00	22.75
BL-L with Manual Closing Gate							
4l-1/2	1050804	-	PIN-LOK	1.60	2.0	.50	3.32
4l-9/16	1050815	-	PIN-LOK	1.70	2.0	.56	3.32
4l-5/8	1050826	5162040800	PIN-LOK	1.70	2.0	.63	3.32
5l	1050837	5164050800	ROLLOX	2.30	3.0	.75	3.55
6l	1050848	5164060800	ROLLOX	4.00	4.0	.88	4.12
7l	1050859	5164070800	ROLLOX	4.20	5.9	1.00	4.75
8l	1050870	5164080800	ROLLOX	5.50	7.8	1.13	5.13
9l	1050881	5164090800	ROLLOX	7.20	10.8	1.25	5.62
11l ††	1050892	5163110800	TIP-LOK	9.20	19.0	1.50	AR
12l ††	1050903	5163120800	TIP-LOK	12.30	28.0	1.63	5.38
13l ††	1050914	-	TIP-LOK	15.00	35.0	1.75	7.38
14l ††	1050925	5163140800	TIP-LOK	18.50	45.0	2.00	5.38
16l †	1050936	-	TIP-LOK	33.00	103.0	2.75	16.00
17l †	1050958	5163170800	TIP-LOK	66.00	370.0	4.00	22.75



BL-K
w/self-closing gate
BL-L
w/manual-closing gate.

* Ultimate Load Is 4x the Working Load Limit.

† Requires a drawing indicating the hook's exact shank diameter, shank length, thread length and throat opening requirements.

†† Hook will have the shank extended by use of a COUPLING NUT.

Nos. 4K - 9K & 4l - 9l style hooks are threaded approximately 80% of shank length.

Link Chain Nest

Hook Size & Type	Crosby Stock No.	Bullard Stock No.	Gate Type	WLL* (tons)	Wt. Each (lbs)
BL-O with Self-Closing Gate					
4O - 1/4	1051409	5162041100	PIN-LOK	1.70	2.5
4O - 9/32	1051420	5162041000	PIN-LOK	1.70	2.5
5O - 5/16	1051431	5164051100	ROLLOX	2.30	2.5
5O - 3/8	1051442	5164051100	ROLLOX	2.30	4.5
7O - 3/8	1051453	5164071100	ROLLOX	4.20	11.0
7O - 7/16	1051464	5164071120	ROLLOX	4.20	11.0
7O - 1/2	1051475	5164071110	ROLLOX	4.20	11.0
7O - 9/16	1051486	5164071130	ROLLOX	4.20	11.0
BL-P with Manual Closing Gate					
4P - 1/4	1051508	5162041210	PIN-LOK	1.70	2.5
4P - 9/32	1051519	5162041200	PIN-LOK	1.70	2.5
5P - 5/16	1051530	5164051210	ROLLOX	2.30	2.5
5P - 3/8	1051541	5164051200	ROLLOX	2.30	4.5
7P - 3/8	1051552	5164071200	ROLLOX	4.20	11.0
7P - 7/16	1051563	-	ROLLOX	4.20	11.0
7P - 1/2	1051574	5164071220	ROLLOX	4.20	11.0
7P - 9/16	1051585	-	ROLLOX	4.20	11.0



BL-O
w/self-closing gate
BL-P
w/manual-closing gate.
With ball-bearing swivel; attaches to chain by alloy pin.

* Ultimate Load is 4x the Working Load Limit

Roller Chain Nest

Hook Size & Type	Crosby Stock No.	Bullard Stock No.	Gate Type	WLL* (tons)	Wt. Each (lbs.)
BL-S with Self-Closing Gate					
4S	1051310	5162041400	PIN-LOK	0.75	2.9
5S	1051321	5164051400	ROLLOX	1.25	5.2
6S	1051332	5164061400	ROLLOX	1.25	6.2
BL-R with Manual Closing Gate					
4R	1051200	5162041300	PIN-LOK	0.75	2.9
5R	1051211	-	ROLLOX	1.25	5.2
6R	1051222	-	ROLLOX	1.25	6.2



BL-S
w/self-closing gate
BL-R
w/manual-closing gate.
Attachment with ball-bearing swivel & full-floating connector.

*Ultimate Load is 4x the Working Load Limit

Rigging Fittings

Crosby® Golden Gate Hooks®

Golden Gate® Hook Dimension Chart

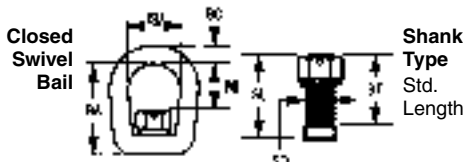

Long Shank
Sizes 2, 3, 4,
5, 6, 7, 8, 9,
16 & 17

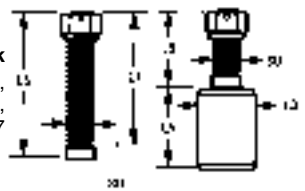

Long Shank
Sizes 11,
12 & 14

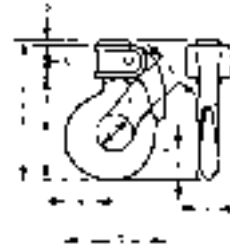

Basic Hook & Gate
Self-closing shown

Hook Size	Dimensions (in)																				WLL* (tons) Style				
	A	B	C	D	E	F	G	H	I	J	SD	SL	ST	LS	LT	LD	LN	BA	BB	BC	BD	A, C	B, D, O.P. E, G, PKU	† I, K	†† R, S
1	3.08	2.37	.63	.08	.72	.88	2.25	.69	.63	.44	-	-	-	-	-	-	-	1.56	.80	.31	1.00	.5	.5	-	-
2	4.07	3.03	.93	.11	.97	1.25	2.88	.81	.75	.56	.50	1.02	.63	-	-	-	-	1.88	.86	.38	1.25	1.0	1	-	-
3	4.50	3.37	.94	.18	1.06	1.37	3.19	.94	.84	.62	.56	1.13	.75	-	-	-	-	2.44	1.31	.50	1.50	1.4	1.4	-	-
4	4.81	3.67	1.00	.18	1.12	1.50	3.62	1.16	1.00	.75	.63	1.32	1.00	3.32	3.25	-	-	2.65	1.33	.50	1.50	1.7	1.7	1.6-1.7	.75
5	5.63	4.18	1.22	.23	1.25	1.62	4.09	1.31	1.12	.84	.75	1.30	1.13	3.55	3.00	-	-	3.00	1.70	.63	1.75	2.3	2.3	2.3	1.25
6	6.01	4.56	1.25	.20	1.37	1.62	4.56	1.56	1.34	.97	.88	1.68	1.13	4.11	3.63	-	-	3.19	1.51	.63	1.75	4	4	4	1.25
7	6.56	5.22	1.13	.21	1.50	2.00	4.94	1.62	1.44	1.12	1.00	1.91	1.50	4.75	4.13	-	-	3.50	1.59	.75	2.00	4.2	4.2	4.2	-
8	7.22	5.80	1.13	.29	1.75	2.25	5.84	2.00	1.69	1.25	1.13	2.08	1.50	5.33	4.75	-	-	4.13	2.05	.88	2.25	5.5	5.5	5.5	-
9	7.95	6.56	1.13	.26	1.87	2.50	6.50	2.06	1.81	1.37	1.25	2.36	1.75	5.61	5.00	-	-	4.67	2.31	1.00	2.50	7.2	7.2	7.2	-
11	9.63	8.13	1.25	.25	2.25	3.00	7.56	2.63	2.25	1.63	1.50	2.75	2.13	A.R.	-	2.38	4.56	4.88	2.13	1.13	2.70	9.2	9.2	9.2	-
12	10.56	8.93	1.25	.38	2.50	3.13	8.69	2.93	2.59	1.93	1.63	2.88	2.13	5.38	4.63	3.00	5.06	5.13	2.25	1.25	3.00	12.3	12.3	12.3	-
13	11.09	9.53	1.25	.31	3.00	3.75	9.63	3.28	2.78	1.94	1.75	3.50	1.88	7.38	5.79	3.00	4.75	7.69	4.63	1.50	4.00	-	15.0	15	-
14	12.67	10.91	1.38	.38	3.38	4.25	11.00	3.50	3.00	2.38	2.00	3.75	2.38	5.38	4.00	3.75	5.44	8.00	4.25	1.50	3.50	18.5	18.5	18.5	-
16	15.06	13.06	1.50	.50	4.00	5.00	13.62	4.62	3.62	3.00	2.75	4.63	3.50	16.00	7.00	-	-	-	-	-	-	-	-	33	-
17	24.75	21.50	2.63	.63	5.75	7.00	18.50	6.50	6.00	4.63	4.00	11.25	10.00	22.75	14.00	-	-	-	-	-	-	-	-	66	-

NOTE: Since hooks and bails are forgings and gates are cast, these dimensions may vary + 2%.
*Ultimate load is 4 times the Working Load Limit. ** Includes Manual and Self Closing Gates for Closed Ball, Universal Bail, Standard Shank, Link Chain, Universal Swivel, and Double Ended Hooks. † Includes Manual and Self Closing Gates for Long Shank Hooks. †† Includes Manual and Self Closing Gates for Roller Chain Hooks.

4 Rigging Fittings

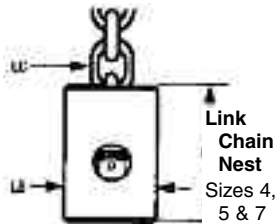

Hook Size	Dimensions (in)		
	LC	LA	LB
4	1/4 & 9/32	2.63	1.75
5	5/16 & 3/8	3.19	2.13
7	3/8 & 9/16	4.38	3.00

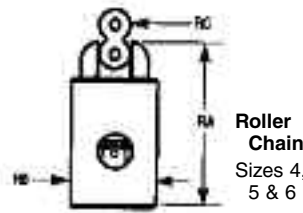

Hook Size	Dimensions (in)		
	RC	RA	RB
4	5/8	3.50	1.75
5	3/4	4.38	2.13
6	3/4	4.38	2.06

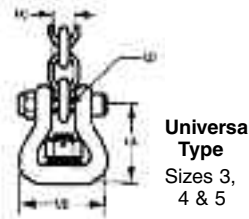

Hook Size	Dimensions (in)			
	UA	UB	UC	UD
3	2.13	2.35	.53	3/8
4	2.13	2.35	.53	3/8
5	2.63	2.63	.65	1/2

ABBREVIATIONS:

- AR = As Required
 - LN & LD = Coupling nut dimensions
 - LS = Length of long Shank
 - LT & ST = Length of thread
 - SL = Length of standard shank
 - E = Throat opening
 - SD = Thread shank diameter
 - LC = Size of link chain
 - RC = Size of roller chain
 - UD = Shank diameter
- Note: All bronze hooks will require shank extensions if shank length exceeds 2'.

Hook Data Form No.1 (Sample) For Hook Sizes 1- 9, 16, or 17

Hook Size: _____
 Sales Order: _____
 Capacity (Tonnage) _____
 Hoist Name and Model: _____
 Top Hook Bottom Hook
 Is Self-Closing Gate Required? Yes No
 Name of Person Completing Form: _____
 Telephone: _____
 Distributor: _____

- 2) Measure threaded portion (enter BLANK if threads not required). NOTE: Hook is supplied with Steel Hex-Load Nut and Bronze Load Washer. Hook and Nut threads are National Coarse. If a SPECIAL Load Nut or Load Washer is required, attach a drawing to this form.

Shank Diameter

- 3) Measure width of threaded portion.
- 4) Measure width of blank portion.

Throat Opening

- 5) ONLY measure throat opening if this distance is critical to customer's operation.

Cross Hole in Shank Hooks

- (complete only if required)
- 6) Measure shank length from center of hole to top of gate assembly.
 - 7) Measure diameter of hole.

FOR INTERNAL USE ONLY			
Bill of Materials: MI Number 516 -			
Part	MI No.	Part	MI No.
Hook	616-	D Washer	616-
Gate	616-	Load Wash	616-
LP	616-	Load Nut	616-
LPN	616-	Bail	616-
LPS	616-	Shaft	616-
Ret Sprg	616-	Extension	616-

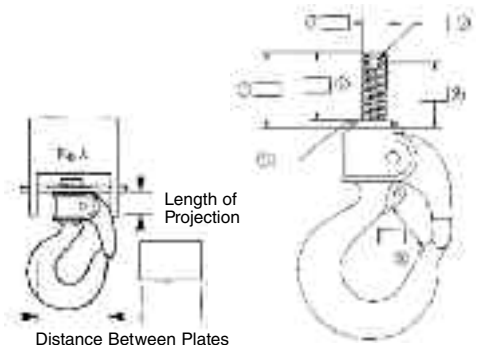

Crosby® Golden Gate Hooks®

Hook Data Form No.2 (Sample) For Hook Sizes 11, 12 or 14

Hook Size: _____
 Sales Order: _____
 Capacity (Tonnage) _____
 Hoist Name and Model: _____
 Top Hook Bottom Hook
 Is Self-Closing Gate Required? Yes No
 Name of Person Completing Form: _____
 Telephone: _____
 Distributor: _____
 Distributor P.O. _____

Accurate dimensions are important. If you have any questions, please contact one of our representatives.

Shank Length

- 1) Measure total USABLE shank length from top of hook shank to top of gate assembly. Gate assembly is not considered part of the USABLE shank. When measuring other manufacturer's hooks, measure from the top of the hook shank to the hook shoulder.
- 2) Measure threaded portion (enter BLANK if threads not required). NOTE: Hook is supplied with Steel Hex-Load Nut and Bronze Load Washer. Hook and Nut threads are National Coarse. If a SPECIAL Load Nut or Load Washer is required, attach a drawing to this form.

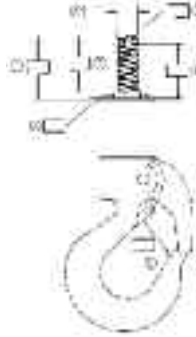

Shank Diameter

- 3) Measure width of threaded portion.
- 4) Measure width of blank portion.

Throat Opening

- 5) ONLY measure throat opening if this distance is critical to customer's operation.

Cross Hole in Shank Hook (complete only if required)

- 6) Measure shank length from center of hole to top of gate assembly.
- 7) Measure diameter of hole.

Logging Hooks

Double-Ender Hook

Versatile and fast. For straight-pull lines, insert ferrule-tipped lines in opposite ends of double-ender hook and you're in business! It's the easy answer for extending portable tower and spare tree guy lines. No need for rope "molly", connecting links or other time-consuming arrangements. Versatile double-ender also speeds second choker extensions-ends costly choker hook damage. Two sizes for lines 7/8" through 1-1/2".

Part No.	Hook	Rope Size (in)	Ferrule Size	Wt. (lbs)
404475	Junior	7/8 - 1-1/4	J7, J8, J9, J10	16
404483	Standard	1 - 1-1/2	S9, S10, S11, S12	23



Screwy® guy line hook

Rig those guy lines in minutes with "Screwy" guy line hooks. Fast simple locking method allows guyline to be pulled out to stump without hook attached. To connect, simply slip ferrule into hook as shown. High strength, for rope sizes 5/8" through 1-1/2".

Part No.	Size (in)	For Rope Sizes (in)	Ferrules to Use*	Wt. (lbs)
404442	Bantam	5/8, 3/4	B5, B6	6
404459	Junior	7/8, 1, 1-1/8, 1-1/4	J7, J8, J9, J10	15
404467	Std.	1-1/4, 1-3/8, 1-1/2	S10, S11, S12	25

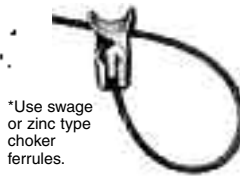

*Use swage or zinc type choker ferrules.

Sleeve-Type Holdrite® Hooks

ESCO Holdrite rigging system speeds the job of choker setting and skidding. These sliding winchline hooks with chokers attached are dropped as winchline is paid out though a group of logs. Chokers are set and winchline reeled in. It slides through hooks gathering all logs at the winch. Chokers are locked in with "Screwy" lock. Haul logs parallel to line of travel, reducing line wear. Reach all logs with standard choker lengths by pulling out winchline. Use with zinc-type, wedge or swage ferrules.

Sleeve-type Holdrite hooks have a smaller sliding slot to hold against the ferrule at the end of winchline and gather ring-type hooks.

Part No.	Hook (Ferrule) Size	Recommended Winch line Sizes (in)	Recommended Choker Sizes (in)	Wt. (lbs)
404491	Midget	1/2, 9/16, 5/8	7/16, 1/2	1-3/4
403220	Midget	9/16, 5/8, 3/4	1/2, 9/16	2-1/4
440222	Dwarf	3/4, 7/8	9/16, 5/8	4



Sliding Winchline Hooks

Protect your winchline with the HOLDRITE® LINENDER™. Available in three sizes to accommodate a variety of winchline / choker combinations, the LINENDER prevents cable end kinking which often leads to premature breakage. Used on skidder winchlines, carriage drop lines and in temporary field repairs, the LINENDER is designed to be a valuable addition to your rigging line.

Part No.	Hook (Ferrule) Size (in)	Winchline Dia. (in)	Choker Line Dia. (in)
445684	Light/Bantam	3/4, 7/8, 1	5/8, 3/4
447615	Light/Dwarf	3/4, 7/8, 1	9/16, 5/8
447532	Bantam/Midget	5/8, 3/4	3/8, 7/16, 1/2, 9/16



Bardon® Choker Hooks

The original and still favorite. Users prefer the tough and dependable Bardon. They're simple and fast to use. And they are made of wear and shock-resistant high alloy steel for increased strength.

Part No.	Hook (Ferrule) Size	Designed for the Following Sizes of Choker Ropes (in)	May also be Used with These Sizes	Wt. (lbs)
440636	Micro-Midget*	1/2	3/8, 7/16, 9/16	3/4
403436	Midget	1/2	3/8, 7/16, 9/16	1-1/2
404319	Dwarf	5/8	1/2, 9/16	3-1/4
404327	Bantam	3/4	5/8, 1/2	4
404335	Light	7/8	3/4, 1	9
404343	Light Jr.**	1	7/8, 1-1/8	11-1/2
404350	Junior	1-1/8	7/8, 1, 1-1/4	13-1/4
404368	Standard	1-1/4	1-1/8, 1-3/8, 1-1/2	21

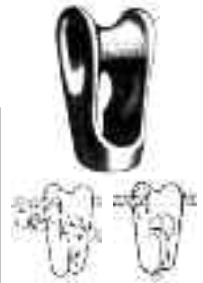

*Uses Midget Ferrules
**Uses Junior Ferrules

Lightweight Bardon® Choker Hooks

Special design in high alloy steel to reduce weight for easier handling without losing strength. Open rope slot and ferrule pocket area makes hook self-cleaning.

Part No.	Hook (Ferrule) Size	Designed for the Following Size Choker (in)	May also be Used with These Sizes (in)	Wt. (lbs)
440545	Bantam	3/4	1/2, 5/8	2-3/4
440537	Light	7/8	3/4, 1	5-1/2
404392	Junior	1, 1-1/8	7/8, 1-1/4	9



Ring-Type Holdrite® Hooks

Same design as sleeve-type hook, except has a larger winchline slot so it slides freely over large kinks or wows in winchline. Two weights: Regular is heavier and stronger for large logs; Light Weight is for smaller pulpwood logs.

Part No.	Hook (Ferrule) Size	Winchline Opening Approx. Dia. (in)	Choker Sizes (in)	Wt. (lbs)
400606 (Reg)	Midget	2	1/2, 9/16	3
441337 (Lt. Wt.)	Midget	2	1/2, 9/16	1-3/4
444562	Dwarf	2	5/8	4
416388	Bantam	2	3/4	6-1/2



Chain Winchline Hooks

Chain chokers can be used in a manner similar to the Holdrite system. Hooks slide freely on winchline. Made of high alloy steel to stand up to chain. Connect with 3/8 or 1/2 inch Hammerlock coupling link

Size Part No.	Winchline Size (in)	Chain Size (in)	Wt. (lbs)
441030	1/2, 5/8, 3/4	3/8, 1/2	2



Chainrite® Choker Hook

The Chainrite hook does it all in chain choker systems. Use it as a sliding winchline hook and as a choker hook. It eliminates the need for other chain hardware.

Size Part No.	Winchline Size (in)	Chain Size (in)	Wt. (lbs)
445056	5/8, 3/4	3/8	2-1/2



Rigging Fittings

Chain Hooks

Eye Grab Hooks - Crosby®

A-323 hooks now rated for use with Grade 8 Chain.*

- Forged Steel—Quenched & Tempered.
- Design factor is 4:1
- H-323 designed for Crosby Spectrum 4[®] chain.
- A-323 designed for Crosby Spectrum 7[®] chain.
- Is suitable for use with Grade 8 chain in over head lifting applications as long as hook is Proof Tested as part of the chain sling assembly or as an individual component per ANSI B30.9-1994.



H-323
A-323

Size of Chain (in)	WLL (lbs)		Inside Dia. of eye (in)	Throat Opening (in)	Wt. Each (lbs)
	H-323	A-323			
1/4	2600	3500	1/2	11/32	.28
5/16	3900	4500	9/16	7/16	.45
3/8	5400	7100	21/32	1/2	.79
1/2	9200	12000	7/8	21/32	1.75
5/8	13000	15800	1-1/16	25/32	3.25
3/4	20200	24700	1-3/8	15/16	5.94

Note: Only A-323 hooks containing an "8" designating Grade 8, have new Working Load Limits.

Eye Slip Hooks - Crosby®

- Forged Carbon Steel—Quenched and Tempered.

Size of Chain (in)	WLL* (lbs.) H-324	Inside Dia. of eye (in)	Throat Opening (in)	Wt. Each (lbs)
1/4	1950	1/2	15/16	.40
5/16	2875	5/8	1-1/16	.64
3/8	4000	23/32	1-5/16	1.10
7/16	5000	13/16	1-9/16	1.56
1/2	6500	15/16	1-11/16	2.09
5/8	9250	1-1/8	2	3.90
3/4	12500	1-3/8	2-1/8	6.93

*Ultimate Load is 4 times the Working Load Limit.



H-324

Clevis Grab Hooks - Crosby®

A-330 hooks now rated for use with Grade 8 Chain.*

- Forged Steel—Quenched and Tempered.
- Features quick and easy assembly
- H-330 designed for Crosby Spectrum 4[®] chain.
- A-330 designed for Crosby Spectrum 7[®] chain.
- Design Factors is 4:1.
- Is suitable for use with Grade 8 chain in over head lifting applications as long as hook is Proof Tested as part of the chain sling assembly or as an individual component per ANSI B30.9-1994.



H-330
A-330

Size of Chain (in)	WLL (lbs)		Inside Width of Eye (in)	Throat Opening (in)	Wt. Each (lbs)
	H-330	A-330			
1/4	2600	3500	7/16	11/32	.36
5/16	3900	4500	1/2	7/16	.62
3/8	5400	7100	19/32	1/2	1.00
7/16	7200	10000	21/32	9/16	1.31
1/2	9200	12000	3/4	21/32	2.22
5/8	13000	15800	29/32	25/32	4.41
3/4	20200	24700	15/16	15/16	6.50

* Only A-330 hooks containing an "8" designating Grade 8, have new Working Load Limits

Clevis Slip Hooks - Crosby®

- Forged Carbon Steel or Forged Alloy Steel—Quenched & Tempered.
- All Pins Alloy Steel—Quenched & Tempered.

Size of Chain (in)	WLL (lbs)		Inside Width of Eye (in)	Throat Opening (in)	Wt. Each (lbs)
	H-331	A-331			
1/4	1950	2750	7/16	15/16	.55
5/16	2875	4300	13/32	1-1/16	.79
3/8	4000	5250	19/32	1-5/16	1.21
7/16	5000	7000	9/16	1-9/16	2.06
1/2	6500	9000	3/4	1-11/16	2.75
5/8	9250	13500	13/16	2	4.75
3/4	—	19250	1-5/16	2-1/2	11.28



H-331
A-331

* Ultimate Work Load is 4x the Working Load Limit.
For sling lifting chains, Grade 8 alloy components are recommended.

Alloy Hooks

Weld-On Hooks BH-313 - Crosby®

- Wide range of sizes available: 1-10 Metric Ton capacity.
- Forged Alloy Steel.
- Designed for attachment to mobile lifting equipment to provide a pick point for easy sling attachment.
- Large weld pad.
- Heavy duty latch interlocks with the hook tip. Replacement latches available.
- Detailed installation and application instructions included with each hook.

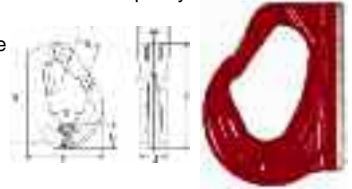

WLL (t)*	BH-313 Stock No	Weight Each (lb)	Dimensions								Replacement Latch Stock No
			B	E	F	G	H	J	K	S	
1	1029105	1.15	.91	3.82	2.80	1.42	1.06	1.02	4.21	.71	1092101
2	1029114	1.85	.91	3.23	3.58	1.42	.98	1.34	4.53	.83	1092101
3	1029123	2.60	1.14	4.61	4.13	1.42	1.22	1.42	5.16	.94	1092101
4	1029132	4.19	1.34	5.16	4.49	1.81	1.42	1.69	5.79	1.14	1092102
5	1029141	5.62	1.34	6.34	5.24	1.85	1.77	1.73	6.81	1.14	1092102
8	1029150	7.28	1.38	6.54	5.31	1.85	2.05	2.05	7.01	1.54	1092102
10	1029169	11.02	1.93	8.07	6.61	1.85	5.24	2.13	8.74	1.54	1092103

*Ultimate Load is 5 times the Working Load Limit.

Alloy Weld-On Hooks

Suitable for: Excavators, Wheel Loaders, Other weld-on applications.

Code	WLL* (tons)	Dimension (in)								Wt. Ea. (lbs)
		B	C	G	H	K	L	S	a	
UKN-1*	1.0	.83	2.8	.67	.99	.99	3.7	.24	.16	1.2
UKN-3	3.0	1.1	4.1	.91	1.2	1.4	5.2	.39	.24	2.2
UKN-4	4.0	1.1	4.4	1.1	1.5	1.7	5.5	.43	.28	4.2
UKN-5	5.0	1.3	5.1	1.2	1.8	1.8	1.5	.47	.32	4.6
UKN-8	8.0	1.3	5.2	1.5	2.0	2.0	6.8	.51	.35	8.2
UKN-10	10.0	1.9	6.6	1.7	2.3	2.2	8.7	.55	.35	11.0

*Design factor 5:1 Proof tested & certified.
Baseplate of hook is 1024C steel (use electrode AWS/ASTM E7018-1, ISO E51 5 B120 20H).
Hook latch is alloy. *Welding plate on UKN 1 is slightly curved.

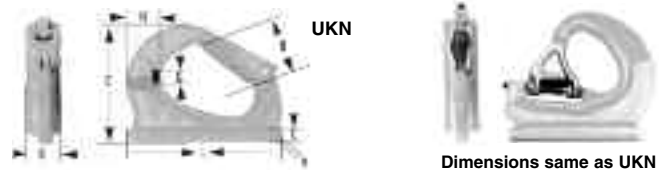

Dimensions same as UKN

Grip Latch, Ball Bearing Swivel

- Ball bearing allows hook to swivel under load.
- Hook latch and bowl interlock for more stability from inadvertent side impact.
- Bail allows attachment to chain, wire rope, or synthetic slings
- Stainless steel spring release trigger will only operate when hook is unloaded.
- Full traceability
- Proof tested to 2 1/2 times working load limit.



Model	Chain Size (in)	WLL (lbs) at 90°	Dimensions (in)						Weight Each	
			L	B	C	E	F	G		H
LKBK-7/8-10	9/32	4,300	6.9	1.5	1.1	1.3	.47	.79	.87	1.8
LKBK-7/8-10	5/16	5,700	6.9	1.5	1.1	1.5	.47	.79	.87	1.8
LKBK-10-10	3/8	8,800	8.4	1.9	1.4	1.7	.59	.87	1.1	4.0
LKBK-13-10	1/2	15,000	9.3	2.1	1.9	1.9	.75	1.1	1.4	8.4
LKBK-16-10	5/8	22,600	12.6	2.7	2.4	2.4	.91	1.1	1.7	13.2

* Design Factor 4:1 Proof tested and certified

Swivels

Eye Type Self-Locking Hook

- The Original Self-Locking Hook.
- Latch closes automatically under load.
- Hook will not open when under load.
- Oversized eye allows attachment to either chain or wire rope slings.
- Stainless steel spring release trigger will only operate when hook is unloaded.
- Full traceability.
- Proof tested to 2 ½ times working load limit.



Model	Chain Size (in)	Grade	WLL (lbs) at 90°	Dimensions (in)						Weight
				L	B	E	F	G	H	
BK-6-10	7/32	100	2,700	4.3	1.1	.87	.39	.59	.83	1.1
BK-7/8-10	9/32	100	4,300	5.4	1.5	1.1	.43	.67	1.0	2.0
BK-7/8-10	5/16	100	5,700	5.4	1.5	1.1	.43	.67	1.0	2.0
BK-10-10	3/8	100	8,800	6.6	1.7	1.3	.51	.83	1.2	3.3
BK-13-10	1/2	100	15,000	8.1	2.1	1.7	.63	1.2	1.5	6.2
BK-16-10	5/8	100	22,600	10.0	2.4	2.2	.79	1.5	1.9	12.3
BK-18/20-10	3/4	100	35,300	11.4	2.7	2.4	.87	1.7	2.5	18.3
BK-22-8	7/8	80	34,200	12.6	3.1	2.8	.95	1.9	2.4	24.7
BK-26-8	1	80	47,700	13.6	3.9	3.1	1.0	2.0	2.7	32.0
BK-28-8	1-1/8	80	55,100	15.7	4.7	3.5	1.1	2.4	3.2	48.5

* Design Factor 4:1 Proof tested and certified **Grade 100 hooks have recessed trigger

Chain Swivels

G-401

- Hot Dip Galvanized
- Quenched and Tempered



Size (in)	G-401 Stock No. Galv.	WLL* (lbs)	Wt. Each (lbs)	Dimensions (in)											
				A	B	C	D	E	G	J	M	R	T	U	V
1/4	1016233	850	.13	1.25	.69	.75	.62	1.12	.25	.69	.31	2.25	2.75	1.69	1.25
5/16	1016251	1250	.25	1.63	.81	1.00	.75	1.38	.31	.81	.38	2.72	3.34	2.06	1.47
3/8	1016279	2500	.54	2.00	.94	1.25	1.00	1.75	.38	1.00	.50	3.44	4.19	2.50	1.88
1/2	1016297	3600	1.12	2.50	1.31	1.50	1.25	2.25	.50	1.31	.63	4.25	5.25	3.19	2.44
5/8	1016313	5200	2.09	3.00	1.56	1.75	1.50	2.75	.62	1.50	.75	5.13	6.31	3.88	2.94
3/4	1016331	7200	3.09	3.50	1.75	2.00	1.75	3.25	.75	1.88	.88	5.78	7.22	4.94	3.46

*Ultimate Load is 5x the Working Load Limit

Regular Swivels

G-402

- Hot Dip Galvanized
- Quenched and Tempered



Size (in)	G-402 Stock No. Galv.	WLL* (lbs)	Wt. Each (lbs)	Dimensions (in)								
				A	B	C	D	J	M	R	S	T
1/4	1016019	850	.21	1.25	.69	.75	1.06	.69	.31	2.94	1.69	3.44
5/16	1016037	1250	.39	1.63	.81	1.00	1.25	.81	.38	3.56	2.06	4.19
3/8	1016055	2250	.71	2.00	.94	1.25	1.50	1.00	.50	4.31	2.50	5.06
1/2	1016073	3600	1.32	2.50	1.31	1.50	2.00	1.31	.63	5.44	3.19	6.44
5/8	1016091	5200	2.49	3.00	1.56	1.75	2.38	1.50	.75	6.56	3.88	7.81
3/4	1016117	7200	4.02	3.50	1.75	2.00	2.63	1.88	.88	7.19	4.31	8.69
7/8	1016135	10000	6.25	4.00	2.06	2.25	3.06	2.13	1.00	8.38	5.00	10.13
1	1016153	12500	8.95	4.50	2.31	2.50	3.50	2.38	1.13	9.63	5.75	11.63
1-1/4	1016199	18000	16.37	5.63	2.69	3.13	3.69	3.00	1.38	11.13	6.75	13.36
1-1/2	1016215	45200	45.79	7.00	4.19	4.00	4.19	4.00	2.25	17.13	10.00	20.13

*Ultimate Load is 5x the Working Load Limit

Jaw End Swivels

G-403

- Hot Dip Galvanized
- Quenched and Tempered

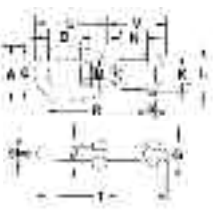

Size (in)	G-403 Stock No. Galv.	WLL* (lbs)	Wt. Each (lbs)	Dimensions (in)													
				A	B	C	G	J	K	L	M	N	P	R	T	U	V
1/4	1016395	850	.21	1.25	.69	.75	.69	.69	.47	1.03	.31	.88	.25	2.63	3.38	1.69	1.69
5/16	1016411	1250	.34	1.63	.81	1.00	.81	.81	.50	1.13	.38	.88	.31	2.94	3.88	2.06	1.81
3/8	1016439	2250	.66	2.00	.94	1.25	1.00	1.00	.63	1.41	.50	1.06	.38	3.63	4.75	2.50	2.25
1/2	1016457	3600	1.34	2.50	1.31	1.50	1.31	1.31	.75	1.75	.63	1.31	.50	4.50	6.06	3.19	2.88
5/8	1016475	5200	2.48	3.00	1.56	1.75	1.63	1.50	.94	2.06	.75	1.50	.63	5.31	7.31	3.88	3.44
3/4	1016493	7200	3.88	3.50	1.75	2.00	1.88	1.88	1.13	2.53	.88	1.75	.75	6.06	8.31	4.31	4.00
7/8	1016518	10000	5.87	4.00	2.06	2.25	2.13	2.13	1.19	2.75	1.00	2.06	.88	7.00	9.53	5.00	4.53
1	1016536	12500	9.84	4.50	2.31	2.50	2.63	2.38	1.75	3.72	1.13	2.81	1.13	8.56	11.69	5.75	5.94
1-1/4	1016572	18000	15.75	5.69	2.69	3.13	3.13	3.00	2.06	4.31	1.50	2.81	1.38	9.44	13.13	6.75	6.38
1-1/2	1016590	45200	54.75	7.00	4.19	4.00	5.63	4.00	2.88	6.00	2.25	4.44	2.25	14.74	20.84	10.00	10.84

*Ultimate Load is 5x the Working Load Limit

Eye & Eye Swivels

- The Eye and Eye Swivel is precision cast and made from grade 316 stainless steel for maximum corrosion resistance. These swivels range in size from 5/32" to 1", making them ideal for various marine and industrial rigging applications.

Item	Dimensions (in)				WLL (lb)	WT (lb)
	A	B	C	D		
S0128-0004	5/32	.43	.50	2.00	150	.12
S0128-0005	3/16	.50	.50	2.31	300	.12
S0128-0006	1/4	.56	.56	2.56	600	.12
S0128-0008	5/16	.75	.75	3.62	1,100	.29
S0128-0010	3/8	.87	1.00	4.39	1,540	.55
S0128-0013	1/2	1.25	1.31	6.00	2,640	1.25
S0128-0016	5/8	1.50	1.62	7.37	4,750	2.10
S0128-0020	3/4	1.62	2.00	8.50	7,000	3.40
S0128-0022	7/8	1.87	2.00	9.25	8,000	5.02
S0128-0025	1	2.50	2.56	11.00	10,000	8.73

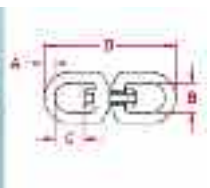

Eye & Jaw Swivels

- The Eye and Jaw Swivel is precision cast and made from grade 316 stainless steel for maximum corrosion resistance and durability. These swivels are available in a variety of sizes ranging from 1/4" to 3/4", making them ideal for various marine and industrial rigging applications.

Item	Dimensions (in)				WLL (lb)	WT (lb)
	A	B	C	D		
S0155-0006	1/4	.50	.43	2.62	600	.33
S0155-0008	5/16	.62	.62	3.62	1,100	.33
S0155-0010	3/8	.75	.87	4.35	1,540	.63
S0155-0013	1/2	1.00	1.12	6.00	2,640	1.40
S0155-0016	5/8	1.25	1.37	7.37	4,750	2.36
S0155-0020	3/4	1.50	1.62	8.62	7,000	3.93

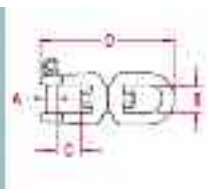

Rigging Fittings

Turnbuckles

Turnbuckle Applications

Campbell carbon turnbuckles are all drop-forged and meet the design requirements of Federal Specification FF-T-791 Type 1, Form 1. All types, except stub-end, are galvanized to ASTM A153 specifications. Campbell stainless turnbuckles are all drop-forged, made of type 316 stainless steel, and have an electropolished finish.

Instructions for Use

1. Turnbuckles are designed for a static load and are typically used with guy wires.
2. Do not exceed working load limit (WLL). See table.

Turnbuckle Size (in)	Carbon Eye & Eye Jaw & Jaw (lbs)	Stainless Eye & Eye Jaw & Jaw (lbs)	Carbon Hook & Hook Jaw & Eye (lbs)
1/4 x 4	500	460	400
5/16 x 4-1/2	800	780	700
3/8 x 6	1,200	1,160	1,000
1/2 x 6, 9, 12	2,200	2,150	1,500
5/8 x 6, 9, 12, 18	3,500	3,440	2,300
3/4 x 6, 9, 12, 18, 24	5,200	5,140	3,000
7/8 x 12, 18	7,200	7,130	3,600
1 x 6, 12, 18, 24	10,000	9,370	4,200
1-1/4 x 12, 18, 24	15,200	*	5,000

Working Load Limits (lbs) - Turnbuckles

3. Stub End Turnbuckles are not rated. The rating is only as good as the weld or connection method.
4. In loads where there is vibration, lock nuts (jam nuts) should be used to prevent the connection from turning or loosening. Lock nuts are available for all turnbuckles and may be ordered separately or assembled on the turnbuckle.
5. The jaw ends come with different hardware depending on their size. Jaws from 1/4" through 5/8" have a hex head bolt and nut. Jaws from 3/4" through 1-1/2" have cotter key and bolt.

Turnbuckle Engineering Data

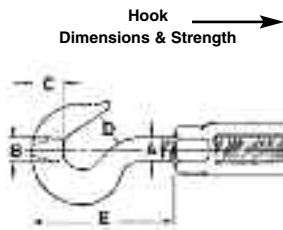

Hook Dimensions (in)					WLL (lbs)
A	B	C	D	E	
1/4	1/4	13/32	29/64	1-21/32	400
5/16	5/16	1/2	1/2	1-31/32	700
3/8	3/8	39/64	9/16	2-23/64	1,000
1/2	1/2	25/32	21/32	2-15/16	1,500
5/8	5/8	1	27/32	3-11/16	2,250
3/4	3/4	1-13/64	63/64	4-33/64	3,000
7/8	7/8	1-3/8	1-1/8	5-3/16	4,000
1	1	1-17/32	1-1/4	5-27/32	5,000
1-1/4	1-1/4	1-13/16	1-1/2	7-7/32	5,000
1-1/2	1-5/16	1-3/4	1-7/8	8-11/32	7,500

Eye Dimensions (in)					WLL (lbs)
A	B	C	D	E	
1/4	11/32	7/32	25/32	1-25/32	500
5/16	7/16	9/32	15/16	2-3/16	800
3/8	17/32	11/32	1-1/8	2-9/16	1,200
1/2	23/32	7/16	1-7/16	3-7/32	2,200
5/8	7/8	1/2	1-3/4	3-7/8	3,500
3/4	1	5/8	2-1/8	4-11/16	5,200
7/8	1-1/4	3/4	2-3/8	5-1/4	7,200
1	1-7/16	7/8	3	6-3/8	10,000
1-1/4	1-13/16	1-1/8	3-9/16	7-3/4	15,200
1-1/2	2-1/8	1-1/4	4-1/8	8-5/8	21,400
1-3/4	2-3/8	1-1/2	4-11/16	10	28,000
2	2-11/16	1-3/4	5-3/4	12-1/8	37,000
2-1/2	3-1/8	2	6-1/2	13-9/16	60,000
2-3/4	3-1/4	2-1/4	7	15	75,000

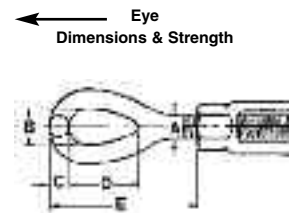

Body Dimensions (in)				WLL (lbs)
A	R	S	T	
1/4	4	4-3/4	3/8	500
5/16	4-1/2	5-7/16	15/32	800
3/8	6	7-1/8	9/16	1,200
1/2	6	7-1/2	3/4	2,200
5/8	6	7-7/8	15/16	3,500
3/4	6	8-1/4	1-1/8	5,200
7/8	6	8-5/8	1-5/16	7,200
1	6	9	1-1/2	10,000
1	12	15	1-1/2	10,000
1	18	21	1-1/2	10,000
1-1/4	24	27	1-1/2	10,000
1-1/4	12	15-1/8	1-9/16	15,200
1-1/4	18	21-1/8	1-9/16	15,200
1-1/2	12	15-3/4	1-7/8	21,400
1-1/2	18	21-3/4	1-7/8	21,400
1-3/4	18	22-3/8	2-3/16	28,000
2	24	29	2-1/2	37,000
2-3/4	24	31	3-1/2	75,000

Jaw Dimensions (in)								WLL (lbs)
A	B	C	D	E	F	G	H	
1/4	5/8	1/4	13/32	9/32	1/2	1-5/8	5/8	500
5/16	7/8	1/4	15/32	9/32	1/2	2	11/16	800
3/8	7/8	5/16	1/2	5/16	19/32	2-3/16	13/16	1,200
1/2	1-1/16	3/8	5/8	13/32	3/4	2-3/4	1	2,200
5/8	1-5/16	1/2	3/4	1/2	1-1/32	3-1/2	1-5/16	3,500
3/4	1-1/2	5/8	15/16	9/16	1-9/32	4-1/8	1-5/8	5,200
7/8	1-3/4	3/4	1-1/8	11/16	1-15/32	4-27/32	1-7/8	7,200
1	2-1/16	7/8	1-3/16	25/32	1-21/32	5-17/32	2-1/8	10,000
1-1/4	2-13/16	1-1/8	1-3/4	1	2-3/32	7-3/16	2-5/8	15,200
1-1/2	2-13/16	1-3/8	2-1/16	1-1/16	2-15/32	7-7/8	3-1/8	21,400
1-3/4	3-3/8	1-5/8	2-3/8	1-1/4	2-29/32	9-3/8	3-1/2	28,000
2	3-11/16	2	2-1/2	1-9/16	3-17/32	10-7/8	4-3/16	37,000
2-1/2	4-7/16	2-1/4	2-7/8	1-9/16	4-5/8	13-11/32	5-5/8	60,000
2-3/4	4-3/16	2-3/4	3-1/2	1-5/8	5-3/8	15	6-1/8	75,000

! Warning !

- Failure to follow the Instructions For Use above and these warnings may cause death or serious injury.
- Use turnbuckles only as indicated.
- Turnbuckles must always be inspected for wear, distortion, cracks and damage before use. If worn, distorted or damaged, discard and replace.
- Turnbuckles are not designed for angular loading, so the loading must be applied in a straight line.

Forged Turnbuckles

Hot dip galvanized forged steel, all end fittings except 1/4, 5/16 and 3/8, sizes quenched and tempered, bodies heat treated by normalizing. Outstanding design features include elongated turnbuckle eyes.

When Ordering Turnbuckles Be Sure to Specify:

- 1st – Diameter of thread.
- 2nd – Length of take-up.
- 3rd – Figure number which will designate the type of end fitting desired.

Jaw End Fittings, sizes 1/4" through 5/8" have Bolts and Nuts. Jaw End Fittings, sizes 3/4" through 2-3/4" have Pins and Cotters.

Hot dip galvanized Lock Nuts available for all sizes - R.H.-G4060, L.H.-G4061. Hooks not supplied on sizes larger than 1-1/2".

	HG-225 Hook & Eye
	HG-226 Eye & Eye
	HG-223 Hook & Hook
	HG-227 Jaw & Eye
	HG-228 Jaw & Jaw

Dia. & Take Up (in)	Ave. Overall w/ Ends in Closed Position (in)	Wt. (lbs)		
		223-225 226 w/Eyes or Hooks	HG 227 Jaw & Eye	HG 228 Jaw & Jaw
*1/4 x 4	8-1/4	.30	.32	.36
*5/16 x 4-1/2	9-9/16	.47	.47	.52
*3/8 x 6	11-7/8	.75	.76	.81
1/2 x 6	13-5/16	1.60	1.53	1.50
9	16-5/16	1.83	1.71	1.74
12	19-5/16	2.08	2.06	2.40
5/8 x 6	15-1/2	2.75	2.35	2.72
9	18-1/2	3.13	3.06	3.24
12	21-1/2	3.50	3.78	3.74
3/4 x 6	17	3.89	4.00	4.11
9	20	4.61	4.75	5.10
12	23	5.43	5.36	5.65
18	29	7.25	7.00	7.00
7/8 x 12	24-5/8	8.10	8.00	8.17
18	30-5/8	9.95	9.75	9.96
1 x 6	20-5/8	9.33	8.92	9.75

Dia. & Take Up (in)	Ave. Overall w/Ends in Closed Position (in)	Wt. (lbs)		
		223-225 226 w/Eyes or Hooks	HG 227 Jaw & Eye	HG 228 Jaw & Jaw
12	26-5/8	11.93	11.20	12.00
18	32-5/8	14.00	13.30	14.00
24	38-5/8	17.25	17.00	17.00
1-1/4 x 12	29-7/8	19.00	20.00	21.50
18	35-7/8	23.00	24.18	24.25
24	41-7/8	27.00	28.50	28.00
1-1/2 x 12	32-3/8	27.50	28.99	30.05
18	38-3/8	31.00	35.00	36.75
24	44-3/8	37.50	39.18	40.67
1-3/4 x 18	41-3/4	52.50	53.75	55.04
24	47-3/4	58.00	60.68	63.36
2 x 24	51-3/4	85.25	89.00	94.25
2-1/2 x 24	58-1/2	144.25	150.00	165.00
2-3/4 x 24	61-1/2	194.00	183.00	198.00

*Normalized

Turnbuckles

Forged Turnbuckles

Material: Turnbuckle—C-1035 and SA-182-F-11 Stub Ends—Hot Rolled, Mild Carbon Steel

Threads: U.N.C. Class 2B, Right or Left Hand

Finish: Self-Colored, Galvanized, Plated

Options: Stainless Steel; Other Alloys; Special Threading



Part No. w/o Stubs	Thd. Dia. D	Take Up A	Max. WLL Kips	w/o Stubs	w/ Stubs	Length of 1 Stub (in)	B	Part No. w/ Stubs
32003	3/8	x 6	1.2	42	78	8	9/16	32103
32004	1/2	x 4	2.2	82	-	-	25/32	-
32005	1/2	x 6	2.2	65	138	8	25/32	32105
32006	1/2	x 9	2.2	90	175	9-1/2	25/32	32106
32007	1/2	x 12	2.2	120	225	11	25/32	32107
32008	5/8	x 4	3.5	82	-	-	15/16	-
32009	5/8	x 6	3.5	98	223	8	15/16	32109
32010	5/8	x 9	3.5	135	290	9-1/2	15/16	32110
32011	5/8	x 12	3.5	158	320	11	15/16	32111
32013	3/4	x 6	5.2	145	328	8-1/2	1-1/16	32113
32014	3/4	x 9	5.2	184	405	10	1-1/16	32114
32015	3/4	x 12	5.2	235	481	11-1/2	1-1/16	32115
32018	7/8	x 6	7.2	185	450	9	1-5/16	32118
32019	7/8	x 12	7.2	302	670	12	1-7/16	32119
32021	1	x 6	9.3	260	632	9-1/2	1-7/16	32121
32022	1	x 12	9.3	402	890	12-1/2	1-7/16	32122
32026	1-1/8	x 6	11.6	406	850	9-1/2	1-9/16	32126
32029	1-1/4	x 6	15.2	400	925	10	1-9/16	32129
32030	1-1/4	x 12	15.2	649	1,385	13	1-9/16	32130
32034	1-3/8	x 6	17.4	615	1,555	10-1/2	1-13/16	32134
32035	1-1/2	x 6	21.0	615	1,555	10-1/2	1-7/8	32135
32036	1-1/2	x 12	21.0	970	2,250	13-1/2	1-7/8	32136
32040	1-5/8	x 6	24.5	980	1,950	11	2-1/2	32140

Part No. w/o Stubs	Thd. Dia. D	Take Up A	Max. WLL Kips	w/o Stubs	w/ Stubs	Length of 1 Stub (in)	B	Part No. w/ Stubs
32041	1-3/4	x 6	28.3	980	2,334	11	2-1/2	32141
32057	1-3/4	x 12	28.3	1,525	3,435	14	2-1/2	32157
32055	1-7/8	x 6	37.2	1,400	3,200	11-1/2	2-13/16	32155
32056	1-7/8	x 12	37.2	1,525	3,660	14-1/2	2-3/4	32156
32042	2	x 6	37.2	1,400	3,430	11-1/2	2-13/16	32142
32043	2	x 12	37.2	1,525	3,980	14-1/2	2-3/4	32143
32044	2-1/4	x 6	48.0	1,960	4,350	12	3-5/16	32144
32052	2-1/4	x 12	48.0	3,092	6,690	16	3-13/16	32152
32045	2-3/8	x 6	52.5	2,325	5,315	13	3-3/4	32145
32046	2-1/2	x 6	60.0	2,325	5,675	13	3-3/4	32146
32050	2-1/2	x 12	60.0	3,092	7,276	16	3-3/4	32150
32059	2-5/8	x 6	65.5	3,150	6,980	13-1/2	4-3/16	32159
32047	2-3/4	x 6	75.0	3,150	7,380	13-1/2	4-3/16	32147
32048	2-7/8	x 6	79.4	3,950	8,710	14	4-3/8	32148
32049	3	x 6	96.7	3,950	9,270	14	4-5/16	32149
32080	3-1/4	x 6	104.0	6,050	12,850	15-1/2	5-7/16	32180
32082	3-1/4	x 12	104.0	7,950	16,373	18-1/2	5-1/4	32182
32085	3-1/2	x 6	122.2	6,050	13,950	15-1/2	5-7/16	32185
32086	3-1/2	x 9	122.2	7,000	15,660	17	5-1/4	32186
32087	3-1/2	x 12	122.2	7,950	17,216	18-1/2	5-1/4	32187
32093	4	x 6	167.8	9,500	22,200	16-1/2	6	32193
32098	4-1/2	x 9	233.8	15,200	32,300	19	6-3/4	32198

Clevises

Forged Steel Adjustable Yoke Ends

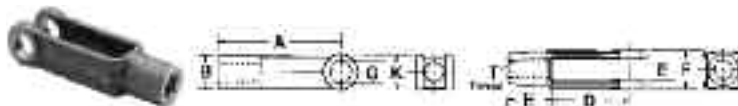

Stock No.	Thread T	Dimensions (in)									Approx. Wt. Per 100 pcs.
		A	B	D	E	F	G	H	K		
69105	1/4-28	2	7/16	1-1/4	9/32	5/8	1/4	3/4	1/2	7	
69110	5/16-24	2-1/4	1/2	1-7/16	11/32	3/4	5/16	13/16	19/32	11	
69115	3/8-24	2-1/2	5/8	1-5/8	7/16	7/8	3/8	7/8	11/16	17	
69120	7/16-20	2-7/8	23/32	1-7/8	1/2	1	7/16	1	13/16	24	
69122	1/2-13	3	13/16	1-7/8	9/16	1-1/8	1/2	1-1/8	15/16	39	
69124	1/2-20LH	3	13/16	1-7/8	9/16	1-1/8	1/2	1-1/8	15/16	39	
69125	1/2-20	3	13/16	1-7/8	9/16	1-1/8	1/2	1-1/8	15/16	39	
69126	1/2-20	4-3/16	13/16	3-1/16	9/16	1-1/8	1/2	1-1/8	15/16	44	
69130	5/8-18	4-15/16	1-1/16	3-11/16	11/16	1-3/8	5/8	1-1/4	1-3/16	75	
69132	5/8-11	4-15/16	1-1/16	3-11/16	11/16	1-3/8	5/8	1-1/4	1-3/16	75	
69135	3/4-16	6-1/16	1-1/4	4-9/16	13/16	1-5/8	3/4	1-1/2	1-7/16	125	
69136	3/4-10	4	1-1/8	2-3/4	11/16	1-1/2	5/8	1-1/4	1-3/8	76	
69137	3/4-10	6-1/16	1-1/4	4-9/16	13/16	1-5/8	3/4	1-1/2	1-7/16	125	

Plain Yoke Ends



- Forged
- Carbon Steel
- Self Colored

Stock No.	Dia. (in)	Dimensions (in)									Approx. Wt. Per 100 pcs.
		A	B	C	D	E	F	G	H	K	
69305	1/4	1-3/4	1/4	1-9/32	5/8	9/32	5/8	1/4	1-1/8	1/2	14
69310	5/16	2	5/16	1-7/16	3/4	11/32	3/4	5/16	1-1/4	19/32	18
69315	3/8	2-1/8	3/8	1-33/64	27/32	7/16	7/8	3/8	1-9/32	11/16	28
69317	3/8	7	3/8	1-33/64	27/32	7/16	7/8	3/8	1-9/32	11/16	58
69320	7/16	2-1/4	7/16	1-33/64	1	1/2	1	7/16	1-1/4	13/16	39
69322	7/16	3-1/2	7/16	1-33/64	1	1/2	1	7/16	1-1/4	13/16	45
69325	1/2	2-1/2	1/2	1-11/16	1-1/8	9/16	1-1/8	1/2	1-3/8	15/16	51
69326	1/2	6-1/2	1/2	5-11/16	1-1/8	9/16	1-1/8	1/2	5-3/8	15/16	83
69330	5/8	2-7/8	5/8	1-53/64	1-7/16	11/16	1-3/8	5/8	1-7/16	1-3/16	76
69332	5/8	4-3/4	5/8	1-53/64	1-7/16	11/16	1-3/8	5/8	1-7/16	1-3/16	101
69335	3/4	3-5/8	3/4	2-25/64	1-11/16	13/16	1-5/8	3/4	1-15/16	1-7/16	128
69337	3/4	8-1/4	3/4	2-25/64	1-11/16	13/16	1-5/8	3/4	1-15/16	1-7/16	209
69345	1	6	1	3-3/64	2-1/2	1-1/16	2-1/8	1	3-1/2	1-15/16	340

Clevis Pins

- Cold Head
- Self-Colored
- For Yoke Ends

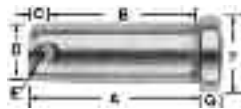

Stock No.	Dimensions (in)							Approx. Wt. Per 100 pcs.
	A	B	C	D	E	F	G	
98305	49/64	43/64	3/32	1/4	5/64	3/8	3/32	1.40
98310	15/16	13/16	1/8	5/16	7/64	7/16	3/32	2.50
98315	1-1/16	15/16	1/8	3/8	7/64	1/2	1/8	4.00
98320	1-3/16	1-1/16	1/8	7/16	7/64	9/16	5/32	6.40
98325	1-23/64	1-13/64	5/32	1/2	9/64	5/8	5/32	9.00
98330	1-39/64	1-29/64	5/32	5/8	9/64	13/16	13/64	17.20
98335	1-29/32	1-23/32	3/16	3/4	11/64	15/16	1/4	28.80
98340	1-27/32	1-19/32	9/64	5/8	9/64	13/16	13/64	100.00



Rigging Fittings

Clevises

Drop-Forged Steel Clevises

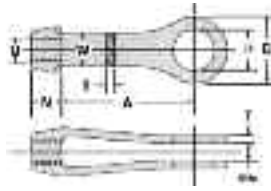

Material: C-1035 and SA-182-F-11 in Stock
Threads: U.N.C. Class 2B, Right or Left Hand
Finish: Self-Colored, Galvanized, Plated

Options: Stainless Steel; Other Alloys; Special Threading
Maximum working loads have been established with a safety factor of 5:1 using the maximum pin diameter, the resulting net area of the eye at the pin hole, and the expected ultimate tensile strength of C-1035 steel.

The maximum tap size (U dimension) shown in Table 1 is for reference purposes only. It should be used only to determine the largest tap diameter the clevis can accommodate without considering the pin diameter. Use Table 2 to select the proper combination of tap size and pin diameter for any given size of clevis.

Clevis sizes in Table 2 for any given tap size and pin diameter combination are based upon the net area of the eye at the pin hole being equal to or greater than 125% of the net area at the minor diameter of a round rod without upset ends, threaded Unified National Coarse Series.

For any combination of tap size and pin diameter shown, the pin in double shear will develop the strength of the rod if both the rod and pin are made from steel having the same physical properties. The pin must be investigated for bending, however; and if inadequate, a larger diameter pin selected. Pins supplied with clevises are made from steel having a min. ultimate tensile strength of 58,000 lbs. per square inch, unless otherwise specified.

If the pin is made from steel with physical properties lower in value than the steel used for the rod, the pin may not develop the strength of the rod in either shear or bending; requiring a larger diameter pin.

Some combinations of tap size and pin diameter shown will not develop the maximum working load of the clevis shown in Table 1. Selection of the rod and pin, the material from which both are made, as well as the clevis size adequate to meet the required design load is the responsibility of the purchaser or user. Load imposed upon the clevis should not exceed the maximum working load values shown in Table 1.

Table 1

Clevis No.	Std. Clevis Dimensions (in)							WLL (kips)	Wt. Each (lbs)
	D	N	U Max.	W	Tolerance	A	P Max.		
2	1-7/16	5/8	5/8	1-1/16	5/16 + 1/32 - 0	3-9/16	3/4	3.5	1
2-1/2	2-1/2	1-1/8	7/8	1-1/4	5/16 + 1/32 - 0	4	1-1/2	7.5	2-1/2
3	3	1-1/4	1-3/8	1-1/2	1/2 + 1/16 - 1/32	5-1/16	1-3/4	15	4
3-1/2	3-1/2	1-1/2	1-1/2	1-3/4	1/2 + 1/16 - 1/16	6	2	18	6
4	4	1-3/4	1-3/4	2	1/2 + 1/16 - 1/16	5-15/16	2-1/4	21	8
5	5	2-1/4	2-1/8	2-1/2	5/8 + 3/32 - 0	7	2-1/2	37.5	16
6	6	2-3/4	2-1/2	3	3/4 + 3/32 - 0	8	3	54	26
7	7	3	3	3-1/2	7/8 + 1/8 - 1/16	9	3-3/4	68.5	36
8	8	4	4	4	1-1/2 + 1/8 - 1/16	10-1/8	4-1/4	135	90

Note: 1 KIP=1,000 pounds

Table 2

Diameter of Pin (in)	Diameter of Tap																		
	1/2	5/8	3/4	7/8	1	1-1/4	1-1/2	1-3/4	2	2-1/4	2-1/2	2-3/4	3	3-1/4	3-1/2	3-3/4	4	4-1/4	
3/8	2	2	2	-	-	-	-	-	-	-	-	-	-	-	-	-	-	-	-
1/2	2	2	2	-	-	-	-	-	-	-	-	-	-	-	-	-	-	-	-
5/8	2	2	2	2-1/2	2-1/2	2-1/2	2-1/2	-	-	-	-	-	-	-	-	-	-	-	-
3/4	-	-	2-1/2	2-1/2	2-1/2	2-1/2	2-1/2	-	-	-	-	-	-	-	-	-	-	-	-
7/8	-	-	2-1/2	2-1/2	2-1/2	2-1/2	2-1/2	3	-	-	-	-	-	-	-	-	-	-	-
1	-	-	-	-	3	3	3	3	3	-	-	-	-	-	-	-	-	-	-
1-1/8	-	-	-	-	3	3	3	3	3-1/2	-	-	-	-	-	-	-	-	-	-
1-1/4	-	-	-	-	3	3	3	3	3-1/2	-	-	-	-	-	-	-	-	-	-
1-3/8	-	-	-	-	3	3	3	3-1/2	3-1/2	4	-	-	-	-	-	-	-	-	-
1-1/2	-	-	-	-	-	3-1/2	3-1/2	4	4	5	-	-	-	-	-	-	-	-	-
1-5/8	-	-	-	-	-	4	4	4	5	5	5	-	-	-	-	-	-	-	-
1-3/4	-	-	-	-	-	4	4	5	5	5	5	-	-	-	-	-	-	-	-
1-7/8	-	-	-	-	-	-	-	5	5	5	5	-	-	-	-	-	-	-	-
2	-	-	-	-	-	-	-	5	5	5	5	6	6	-	-	-	-	-	-
2-1/8	-	-	-	-	-	-	-	5	5	6	6	6	6	-	-	-	-	-	-
2-1/4	-	-	-	-	-	-	-	-	6	6	6	6	6	7	7	-	-	-	-
2-3/8	-	-	-	-	-	-	-	-	6	6	6	6	7	7	7	-	-	-	-
2-1/2	-	-	-	-	-	-	-	-	6	6	6	7	7	7	7	-	-	-	-
2-5/8	-	-	-	-	-	-	-	-	-	7	7	7	7	7	8	-	-	-	-
2-3/4	-	-	-	-	-	-	-	-	-	7	7	7	8	8	8	-	-	-	-
2-7/8	-	-	-	-	-	-	-	-	-	7	8	8	8	8	8	8	-	-	-
3	-	-	-	-	-	-	-	-	-	7	8	8	8	8	8	8	8	-	-
3-1/8	-	-	-	-	-	-	-	-	-	-	8	8	8	8	8	8	8	-	-
3-1/4	-	-	-	-	-	-	-	-	-	-	8	8	8	8	8	8	8	-	-
3-3/8	-	-	-	-	-	-	-	-	-	-	8	8	8	8	8	8	8	-	-
3-1/2	-	-	-	-	-	-	-	-	-	-	8	8	8	8	8	8	8	-	-
3-5/8	-	-	-	-	-	-	-	-	-	-	8	8	8	8	8	8	8	-	-
3-3/4	-	-	-	-	-	-	-	-	-	-	8	8	8	8	8	8	8	-	-
3-7/8	-	-	-	-	-	-	-	-	-	-	8	8	8	8	8	8	8	-	-
4	-	-	-	-	-	-	-	-	-	-	8	8	8	8	8	8	8	-	-

Hot Formed Products

We hot form stainless steel whip restraints. For other special applications, we hot form rods of carbon, stainless or other alloy material into oval, S, U or custom shapes. We specialize in assemblies which include threaded rods, turnbuckles, clevises, coupling nuts, sleeve nuts, heavy hex and eye nuts, etc. These assemblies can be shipped to your job site self-colored, painted or galvanized, as required.



Rings
To 4" Stock Dia.

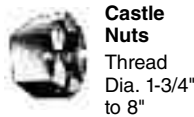

Castle Nuts
Thread Dia. 1-3/4" to 8"



Anchor Shackles
To 4" Dia.



Plain Yoke Assemblies
3-16" to 1" Rod Dia.



Ring Eyebolts
To 3" Stock Dia.



Plate Washers
To 8" Bolt Dia.



Chain Shackles
To 4" Dia.



Turnbuckle Assembly
Made to Specifications



U-Bolts
To 4" Dia.



Shoulder Eyebolts
To 2-1/2" Dia.



Adj. Yoke Ends
3/16" to 3/4" Tap Dia.

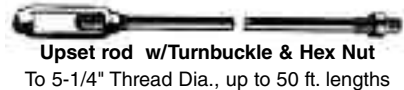

Upset rod w/Turnbuckle & Hex Nut
To 5-1/4" Thread Dia., up to 50 ft. lengths

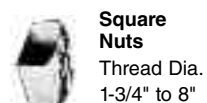

Square Nuts
Thread Dia. 1-3/4" to 8"



Plain Eyebolts
To 2-1/2" Dia.



Heavy Bolts
To 6" Dia.

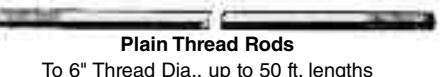

Plain Thread Rods
To 6" Thread Dia., up to 50 ft. lengths

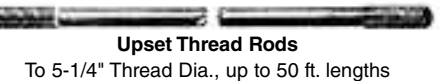

Upset Thread Rods
To 5-1/4" Thread Dia., up to 50 ft. lengths

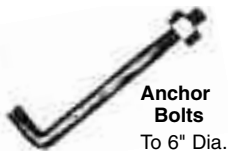

Anchor Bolts
To 6" Dia.

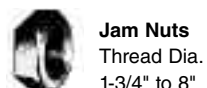

Jam Nuts
Thread Dia. 1-3/4" to 8"



Special Eyebolts
To 2-1/2" Dia.

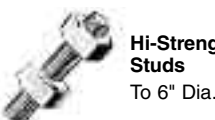

Hi-Strength Studs
To 6" Dia.



Loop Rods
To 6" Dia.



Jaws
1" to 12" Thread

Hoist Rings

Hoist Ring Application Assembly Safety

- Use swivel hoist ring only with a ferrous metal (steel, iron) or soft metal (i.e., aluminum) loads (work piece). Do not leave threaded end of hoist ring in aluminum loads for long time periods due to corrosion.
- After determining the loads on each hoist ring, select the proper size hoist ring using the Working Load Limit ratings in Table 1 for UNC threads and Table 2 for Metric threads.
- Drill and tap the work piece to the correct size to a minimum depth of one-half the threaded shank diameter plus the threaded shank length. See rated load limit and bolt torque requirements imprinted on top of the swivel trunnion. (See Table 1 and/or Table 2)
- Install hoist ring to recommended torque with a torque wrench making sure the bushing flange meets the load (work piece) surface.
- Never use spacers between bushing flange and mounting surface.
- Always select proper load rated lifting device for use with Swivel Hoist Ring.
- Attach lifting device ensuring free fit to hoist ring bail (lifting ring). (Fig. 1)
- Apply partial load and check proper rotation and alignment. There should be no interference between load (work piece) and hoist ring bail. (Fig. 2)
- Special Note: When a Hoist Ring is installed with a retention nut, the nut must have full thread engagement and must meet one of the following standards to develop the Working Load Limit (WLL).
 - ASTM A-563 (A) Grade D Hex Thick (B) Grade DH Standard Hex
 - SAE Grade 8 - Standard Hex

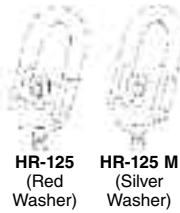

- Always make sure there are no spacers (washers) used between bushing flange and the mounting surface. Remove any spacers (washers) and retorquing before use.
- Always ensure free movement of bail. The bail should pivot 180° and swivel 360°. (Fig. 4)
- Always be sure total work piece surface is in contact with hoist ring bushing mating surface. Drilled and tapped hole must be 90° to load (work piece) surface.
- Never exceed the capacity of the swivel hoist ring, see Table 1 for UNC threads and Table 2 for Metric threads.
- When using lifting slings of two or more legs, make sure the forces in the legs are calculated using the angle from the vertical to the leg and select the proper size swivel hoist ring to allow for the angular forces. (Note: Sling angles will de-rate sling members (chain, rope, or webbing) but will not de-rate swivel hoist ring capacity.)

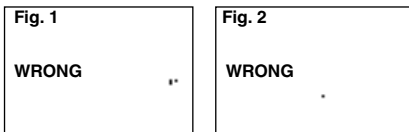
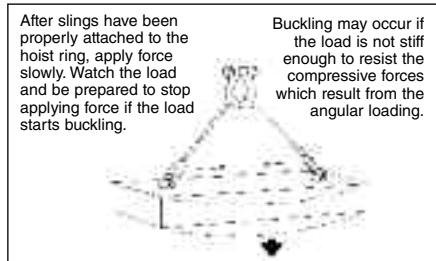
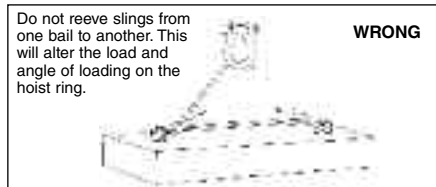
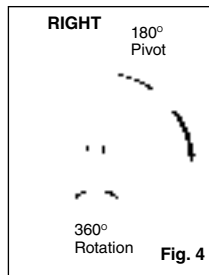
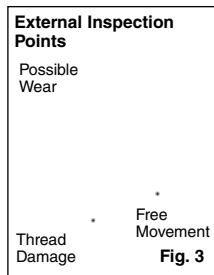

Hoist Ring Inspection/ Maintenance

- Always inspect hoist ring before use.
- Regularly inspect hoist ring parts. (Fig. 3)
- Never use hoist ring that shows signs of corrosion, wear or damage.
- Never use hoist ring if bail is bent or elongated.
- Always be sure threads on shank and receiving holes are clean, not damaged, and fit properly.
- Always check with torque wrench before using an already installed hoist ring.

Table 1 - HR-125 Swivel Hoist Rings

WLL* (lbs)	Torque** (ft/lbs)	Bolt Size†† (in)	Effective Thread Projection Length (in)
800	7	5/16 - 18 x 1.50	.59
1000	12	3/8 - 16 x 1.50	.59
2500	28	1/2 - 12 x 2.00	.71
2500	28	1/2 - 13 x 2.50	1.21
4000	60	5/8 - 11 x 2.00	.71
4000	60	5/8 - 11 x 2.75	1.46
5000	100	3/4 - 10 x 2.25	.96
5000	100	3/4 - 10 x 2.75	1.46
7000	100	3/4 - 10 x 2.75	.90
7000	100	3/4 - 10 x 3.50	1.65
8000	160	7/8 - 9 x 2.75	.90
8000	160	7/8 - 9 x 3.50	1.65
10000	230	1 - 8 x 3.00	1.15
10000	230	1 - 8 x 4.00	2.15
15000	470	1-1/4 - 7 x 4.50	2.22
24000	800	1-1/2 - 6 x 6.50	2.98
30000	1100	2 - 4-1/2 x 6.50	2.98

* Ultimate load is 5 times the Working Load Limit. Individually proof tested to 2-1/2 times the Working Load Limit.
** The tightening torque values shown are based upon threads being clean, dry and free of lubrication.
† Long bolts are designed to be used with soft metal (i.e., aluminum) work piece. While the long bolts may also be used with ferrous metal (i.e., steel & iron) work pieces, short bolts are designed for ferrous work pieces only.
†† Bolt specification is a Grade 8 Alloy socket head cap screw to ASTM A 574. All threads are UNC-3A.

Table 2 - HR-125M Metric Swivel Hoist Rings*

WLL (kg)		Torque In N-m	Bolt Size †† (in)	Effective Thread Projection Lgth. (mm)
At a 5:1 Design Factor†	At a 4:1 Design Factor†			
400	500	10	M 8 x 1.25 x 40	16.9
450	550	16	M10 x 1.50 x 40	16.9
1050	1300	38	M12 x 1.75 x 50	17.2
1900	2400	81	M16 x 2.00 x 60	27.2
2150	2700	136	M 20 x 2.50 x 65	31.2
3000	3750	136	M 20 x 2.50 x 75	28.1
4200	5250	312	M 24 x 3.00 x 80	33.1
7000	8750	637	M 30 x 3.50 x 100	45.1
11000	13750	1005	M 36 x 4.00 x 150	60.6
12500	15600	1005	M 42 x 4.50 x 160	70.6
13500	16900	1350	M 48 x 5.00 x 160	70.6

* Designed to be used with ferrous work piece only.
** The tightening torque values shown are based upon threads being clean, dry and free of lubrication.
† Individually proof tested to 2-1/2 times the Working Load Limit based on the 4:1 design factor.
†† Bolt specification is a Grade 12.9 Alloy socket head cap screw to DIN 912. All threads are metric (ASME/ANSI B1 8.3.1 m).

! WARNING !

- Loads may slip or fall if proper Hoist Ring assembly and lifting procedures are not used.
- A failing load may cause serious injury or death.
- Use only genuine Crosby parts as replacements.
- Read, understand and follow all instructions, diagrams and chart information before using swivel hoist ring assembly.

Forged Hoist Rings (Pivoting, Non-Rotating) - Actek™

- Forged Ring pivots 180° but does not rotate. To obtain maximum load capacity, high strength socket head cap screws must be used.
- Fixed mounting plate holds ring secure to prevent rotation
- Rated loads from 2,000 lbs. to 20,000 lbs.
- Great for anchor of tiedown applications as well as for lifting boxes or containers
- Material: 4140 Forged alloy steel
- Finish: Black oxide
- Safety factor: 6:1
- Magnetic particle inspected
- Heat treated

Part No.	Std. Screw				Metric Screw		
	Part No.	Thread Size	Screw Length	Part No.	Thread Size	Screw Length	
68060	46144	5/16 - 18	1-1/4	49142	M8 x 1.25	30	
68070	46146	3/8 - 16	1-1/4	49146	M10 x 1.50	35	
68080	46048	1/2 - 13	2	49048	M12 x 1.75	50	
68090	46052	1/2 - 13	2-1/2	49048	M12 x 1.75	50	
68100	46043	5/8 - 11	3	49056	M16 x 2.00	60	

Part No.	Rated Load (lbs)	Dimensions (in)								Install Torque (ft/lbs)
		A (dia)	B	C	D	E	F	G	R	
68060	2,000	1-3/4	2	1	5/16	2-1/2	3/4	-	1/2	4-7
68070	2,500	2-1/4	2-1/2	1-1/8	3/8	3-3/16	7/8	-	5/8	7-10
68080	5,000	2-5/8	3	1-1/2	1/2	3-7/8	1-1/8	-	3/4	20-25
68090	12,000	3-1/8	4	1-5/8	3/4	5-1/8	1-3/8	1-1/4	7/8	20-25
68100	20,000	3-5/8	5	2-1/16	1	6-3/8	1-7/8	1-1/4	1	30-35

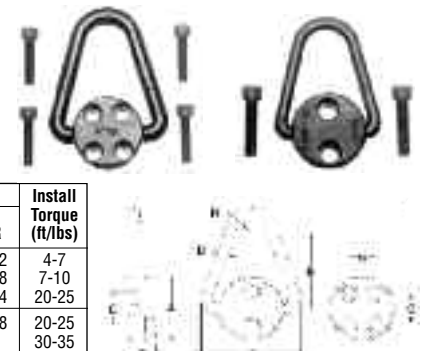

Rigging Fittings

Hoist Rings

Swivel Hoist Rings - Crosby®



Available in UNC and Metric thread sizes.

- UNC threads available in sizes from 800 pounds to 100,000 pounds Working Load Limit, with a design factor of 5 to 1.
- Metric threads available in sizes from 400kg to 16,900kg and dual rated in both a 4 to 1 and 5 to 1 design factor.

- All Components are Alloy Steel - Quenched and Tempered.
- Rated at 100% at 90° angle.
- 100% individually proof tested to 2-1/2 times the Working Load Limit with certification and Statistically Magnetic Particle Inspected. (Can be furnished 100% Magnetic Particle inspected when requested at time of order.)
- Each product has a Product Identification Code (PIC) for material traceability along with a Working Load Limit and the name Crosby or "CG" stamped into it.
- Meets or exceeds all the requirements of ASME B30.26 including identification, ductility, design factor, proof load and temperature requirements. Importantly, these hoist rings meet other critical performance requirements including fatigue life, impact properties and material traceability, not addressed by ASME B30.26.
- 360° swivel and 180° pivot action.
- Fatigue rated to 20,000 cycles at 1-1/2 times the Working Load Limit.
- Individually packaged along with proper application instructions and warning information.
- Bolt is secured with E-clip, threads are grooved. This method allows for easy disassembly and assembly of hoist ring for thorough examination of all components. Replacement kits are available.
- Bolts are individually Proof Tested.
- Multiple Bolt length available to meet specific application requirements.
- Zinc Plated (Yellow Chromate) finish for increased corrosion protection thru 30,000 pounds size.

4

Rigging Fittings

UNC THREADS – HR-125

- Top washer has the following features:
 - The Working Load Limit and Recommended Torque value are permanently stamped into each washer.
 - Washer is color coded for easy identification: Red - UNC thread.
- Individually Proof Tested to 2-1/2 times Working Load Limit.
- Bolt specification is a Grade 8 Alloy socket head cap screw to ASTM A 574. All threads listed are UNC.
- **BOLT SIZE IDENTIFICATION:** The size of the bolt will be stated as in the drawing below. Illustration shows meaning of each dimension given.
- Frame 2 and larger are **RFID EQUIPPED.**

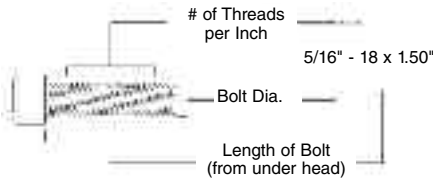
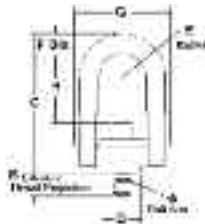

Frame Size No.	HR-125 Stock No.	Working Load Limit (lb)*	Torque in Ft. Lbs	Dimensions (in)								Weight Each (lb)
				Bolt Size A	Effective Thread Projection Length B	C	D	Radius E	Diameter F	G	H	
1†	1016887	800	7	5/16 - 18 x 1.50	.58	2.72	.97	.46	.34	1.87	1.12	.37
1†	1016898	1000	12	3/8 - 16 x 1.50	.58	2.72	.97	.46	.34	1.87	1.05	.39
2	1016909	2500	28	1/2 - 13 x 2.00	.70	4.85	1.96	.87	.69	3.35	2.29	2.33
2†	1016912	2500	28	1/2 - 13 x 2.50	1.20	4.85	1.96	.87	.69	3.35	2.29	2.36
2	1016920	4000	60	5/8 - 11 x 2.00	.70	4.85	1.96	.87	.69	3.35	2.16	2.41
2†	1016924	4000	60	5/8 - 11 x 2.75	1.45	4.85	1.96	.87	.69	3.35	2.16	2.47
2	1016931	5000	100	3/4 - 10 x 2.25	.95	4.85	1.96	.87	.69	3.35	2.04	2.52
2†	1016935	5000	100	3/4 - 10 x 2.75	1.45	4.85	1.96	.87	.69	3.35	2.04	2.59
3	1016942	7000**	100	3/4 - 10 x 2.75	.89	6.57	2.96	1.36	.94	4.87	2.97	6.72
3†	1016946	7000**	100	3/4 - 10 x 3.50	1.64	6.57	2.96	1.36	.94	4.87	2.97	6.81
3	1016953	8000	160	7/8 - 9 x 2.75	.89	6.57	2.96	1.36	.94	4.87	2.84	6.84
3†	1016957	8000	160	7/8 - 9 x 3.50	1.64	6.57	2.96	1.36	.94	4.87	2.84	6.96
3	1016964	10000	230	1 - 8 x 3.00	1.14	6.57	2.96	1.36	.94	4.87	2.72	7.09
3†	1016969	10000	230	1 - 8 x 4.00	2.14	6.57	2.96	1.36	.94	4.87	2.72	7.31
4	1016975	15000	470	1-1/4 - 7 x 4.50	2.21	8.72	3.71	1.75	1.19	6.18	3.93	14.51
5	1016986	24000	800	1-1/2 - 6 x 6.75	2.73	12.55	4.71	2.39	1.75	8.48	5.52	37.73
5	1016997	30000	1100	2 - 4-1/2 x 6.75	2.73	12.55	4.71	2.39	1.75	8.48	5.02	40.69
6	1017001	50000	2100	2-1/2 - 4 x 8.0	4.00	16.88	5.75	3.00	2.25	11.00	8.03	88.00
7	1017005	75000	4300	3 - 4 x 10.5	5.00	19.50	7.25	3.75	2.75	14.16	8.50	166.00
8	1017009	100000	5100	3-1/2 - 4 x 13.0#	7.00	22.09	7.75	4.00	3.25	15.91	9.28	265.00



*Ultimate Load is 5 times the Working Load Limit.
** Ultimate Load is 4.5 times the Working Load Limit for 7000# Hoist Ring when tested in 90 degree orientation. † Long Bolts are designed to be used with soft metal (i.e., aluminum) work piece. While the long bolts may also be used with ferrous metal (i.e., steel & iron) work piece, short bolts are designed for ferrous work pieces only. ‡ Bolt specification is a Grade 8 Alloy socket head cap screw to ASTM A 574. # Hex head bolt used on Frame 8 (100,000lb.) Hoist Ring.

Metric Threads – HR125M

- Top washer has the following features:
 - The Working Load Limit and Recommended Torque value are permanently stamped into each washer.
 - Washer is color coded for easy identification: Silver - Metric thread.
- Individually Proof Tested to 2-1/2 times Working Load Limit.
- Bolt specification is a Grade 12.9 Alloy socket head cap screw to Din 912. All threads listed are metric (ASME/ANSI B18.3.1m).
- Designed to be used with ferrous work piece only.
- **BOLT SIZE IDENTIFICATION:** The size of the bolt will be stated as in the drawing below. Illustration shows meaning of each dimension given.
- Frame 2 and larger **RFID EQUIPPED.**

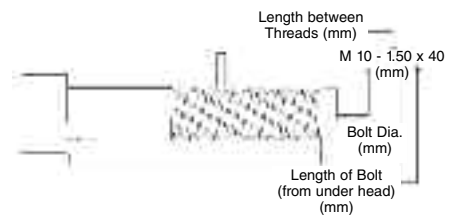
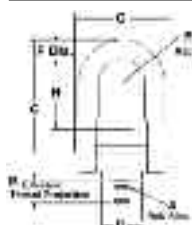

– continues –

HR-125M (continued)

Frame Size No.	HR-125M Stock No.	Working Load Limit (kg)		Torque in Nm*	Dimensions (mm)								Weight Each (kg)
		At a 5:1 Design Factor †	At a 4:1 Design Factor †		Bolt Size ‡ A	Effective Thread Projection Length B	C	D	Radius E	Dia. F	G	H	
1	1016602	400	500	10	M8 X 1.25 X 40	16.7	69.2	24.6	11.7	8.5	47.5	28.2	0.17
1	1016613	450	550	16	M10 X1.50 X 40	16.7	69.2	24.6	11.7	8.5	47.5	26.2	0.18
2	1016624	1050	1300	38	M12 X 1.75 X 50	16.9	123	49.8	22.1	17.5	85.1	58.9	1.05
2	1016635	1900	2400	81	M16 X 2.00 X 60	26.9	123	49.8	22.1	17.5	85.1	54.9	1.11
2	1016644	2150	2700	136	M20 X 2.50 X 65	31.9	123	49.8	22.1	17.5	85.1	50.9	1.17
3	1016657	3000	3750	136	M20 X 2.50 X 75	27.8	167	75.2	34.5	25.4	124	74.4	3.09
3	1016668	4200	5250	312	M24 X 3.00 X 80	32.8	167	75.2	34.5	25.4	124	70.4	3.21
4	1016679	7000	8750	637	M30 X 3.50 X 120	61.7	222	94.2	44.5	30.5	157	101	6.53
5	1016690	11000	13750	1005	M36 X 4.00 X 150	60.3	316	120	60.7	44.5	215	145	16.8
5	1016701	12500	15600	1005	M42 X 4.50 X 160	70.3	316	120	60.7	44.5	215	139	17.4
5	1016712	13500	16900	1350	M48 X 5.00 X 160	70.3	316	120	60.7	44.5	215	133	18

*The tightening torque values shown are based upon threads being clean, dry and free of lubrication.
† Individually proof loaded to 2-1/2 times the Working Load Limit based on the 4:1 design factor.
‡ Bolt specification is a Grade 12.9 Alloy socket head cap screw to Din 912. All threads are metric (ASME/ANSI B18.3.1m).

Heavy Lift Swivel Hoist Rings - HR-1000

- Forged bail provides the following:
 - Easily readable "Raised Lettering" showing the name Crosby or "CG" and PIC Code for material traceability.
 - Greater durability providing the increased "Toughness" desired in potentially abusive field conditions.
- Larger opening than standard Hoist Ring bail.
- Top washer is color coded for easy identification (Red for UNC threads and Silver for Metric threads)
- The Working Load Limit and Recommended Torque value are permanently stamped into each washer.
- Individually Proof Tested to 2-1/2 times Working Load Limit.
- Available in both UNC Thread and Metric Thread style.
- **BOLT SIZE IDENTIFICATION:** The size of the bolt will be stated as in the drawing below. Illustration shows meaning of each dimension given.

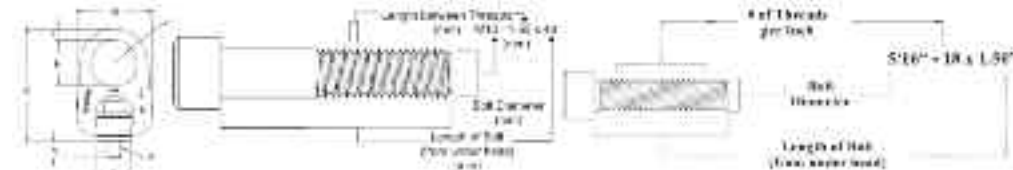

HR-1000 UNC Threads

Frame Size No.	HR-1000 Stock No.	Working Load Limit (lbs)	Torque in Ft. Lbs.	Dimensions (in)									Weight Each (lbs)
				Bolt Size A ‡	Eff. Thread Projection Length B	C	D	Radius E	Dia. F	G	H		
1	1068002	800	7	5/16 -18 x 1.50	.52	3.69	.97	.62	.44	2.27	1.38	.60	
1	1068006	1000	12	3/8 - 16 x 1.50	.52	3.69	.97	.62	.44	2.27	1.38	.62	
2	1068010	2500	28	1/2 - 13 x 2.25	.69	6.26	1.96	1.25	.62	4.20	2.50	3.05	
2†	1068014	2500	28	1/2 - 13 x 2.75	1.19	6.26	1.96	1.25	.62	4.20	2.50	3.07	
2	1068018	4000	60	5/8 - 11 x 2.25	.69	6.26	1.96	1.25	.62	4.20	2.50	3.11	
2†	1068022	4000	60	5/8 - 11 x 3.00	1.44	6.26	1.96	1.25	.62	4.20	2.50	3.18	
2	1068026	5000	100	3/4 - 10 x 2.50	.94	6.26	1.96	1.25	.62	4.20	2.50	3.24	
2†	1068030	5000	100	3/4 - 10 x 3.00	1.44	6.26	1.96	1.25	.62	4.20	2.50	3.30	
3	1068034	7000**	100	3/4 - 10 x 3.00	.85	8.66	2.96	1.63	1.00	6.25	3.25	10.09	
3†	1068038	7000**	100	3/4 - 10 x 3.50	1.35	8.66	2.96	1.63	1.00	6.25	3.25	10.21	
3	1068042	8000	160	7/8 - 9 x 3.00	.85	8.66	2.96	1.63	1.00	6.24	3.25	10.21	
3†	1068046	8000	160	7/8 - 9 x 3.50	1.35	8.66	2.96	1.63	1.00	6.24	3.25	10.40	
3	1068050	10000	230	1 - 8 x 3.50	1.35	8.66	2.96	1.63	1.00	6.24	3.25	10.50	
3†	1068054	10000	230	1 - 8 x 4.50	2.35	8.66	2.96	1.63	1.00	6.24	3.25	10.72	
4	1068058	15000	470	1-1/4 - 7 x 5.00	2.09	11.21	3.71	2.00	1.25	7.82	4.00	21.90	
4	1068062	24000	800	1-1/2 - 6 x 5.50	2.59	11.21	3.71	2.00	1.25	7.82	4.00	23.00	

*Ultimate Load is 5 times the Working Load Limit.
Ultimate Load is 4.5 times the Working Load Limit for 7000# Hoist Ring when tested in 90 degree orientation. * Individually proof loaded to 2-1/2 times the Working Load Limit based on the 4:1 design factor. † Long Bolts are designed to be used with soft metal (i.e., aluminum) work piece. While the long bolts may also be used with ferrous metal (i.e., steel & iron) work piece, short bolts are designed for ferrous work pieces only. ‡ Bolt specification is a Grade 8 Alloy socket head cap screw to ASTM A 574. †† Bolt specification is a Grade 12.9 Alloy socket head cap screw to DIN 912. NOTE: The tightening torque values shown are based upon threads being clean, dry and free of lubrication.

HR-1000M Metric Threads

Frame Size No.	HR-1000M Stock No.	Working Load Limit (kg)*		Torque in Nm*	Dimensions (mm)								Weight Each (kg)
		At a 5:1 Design Factor ***	At a 4:1 Design Factor ***		Bolt Size A ††	Effective Thread Projection Length (B)	C	D	Radius E	Dia. F	G	H	
1	1068307	400	500	10	M8 x 1.25 x 40	15.2	93.7	24.6	15.7	11.2	57.7	35.1	0.3
1	1068316	450	550	16	M10 x 1.50 x 40	15.2	93.7	24.6	15.7	11.2	57.7	35.1	0.3
2	1068325	1050	1300	38	M12 x 1.75 x 55	15.5	162	49.8	31.8	19.1	107	63.5	1.5
2	1068334	1900	2400	81	M16 x 2.00 x 65	25.5	162	49.8	31.8	19.1	107	63.5	1.5
2	1068343	2150	2700	136	M20 x 2.50 x 70	30.5	162	49.8	31.8	19.1	107	63.5	1.6
3	1068352	3000	3750	136	M20 x 2.50 x 80	25.4	220	75.2	41.4	25.4	159	82.6	4.6
3	1068361	4200	5250	312	M24 x 3.00 x 90	35.4	220	75.2	41.4	25.4	159	82.6	4.8
4	1068370	7000	8750	637	M30 x 3.50 x 140	66.2	285	94.2	50.8	31.8	199	102	9.7
4	1068389	11000	13750	1005	M36 x 4.00 x 130	56.2	285	94.2	50.8	31.8	199	102	10.2

*Ultimate Load is 5 times the Working Load Limit.
Ultimate Load is 4.5 times the Working Load Limit for 7000# Hoist Ring when tested in 90 degree orientation. * Individually proof loaded to 2-1/2 times the Working Load Limit based on the 4:1 design factor. † Long Bolts are designed to be used with soft metal (i.e., aluminum) work piece. While the long bolts may also be used with ferrous metal (i.e., steel & iron) work piece, short bolts are designed for ferrous work pieces only. ‡ Bolt specification is a Grade 8 Alloy socket head cap screw to ASTM A 574. †† Bolt specification is a Grade 12.9 Alloy socket head cap screw to DIN 912. NOTE: The tightening torque values shown are based upon threads being clean, dry and free of lubrication.

Hoist Rings

Swivel (Safety) Hoist Rings - Acteck™

Rated Loads (lbs)	Thread Size (in)	A	C	D	E	Standard U-Bar			Long U-Bar			G	H	Torque (ft/#)	Wt. (lbs)	
						Part No.	B	F	Part No.	B	F					
UNC THREADS																
600	1/4 - 20	0.43	0.71	3/8	0.54	46100	1.27	2.67	-	-	-	1.84	1.00	6	0.3	
800	5/16 - 18	0.43	0.71	3/8	0.29	46102	1.27	2.67	-	-	-	1.84	1.00	7	0.3	
800	5/16 - 18	0.43	0.71	3/8	0.54	46104	1.27	2.67	-	-	-	1.84	1.00	7	0.3	
1,000	3/8 - 16	0.43	0.71	3/8	0.54	46106	1.27	2.67	-	-	-	1.84	1.00	12	.03	
2,000	7/16 - 14	0.70	0.93	1/2	1.07	46606	1.84	3.77	-	-	-	2.58	1.49	22	1.0	
2,500	1/2 - 13	0.70	0.93	1/2	1.07	46602	1.84	3.77	-	-	-	2.58	1.49	28	1.0	
2,000	7/16 - 14	0.88	1.22	3/4	0.78	46000	2.31	4.78	46638	4.25	6.72	3.52	1.99	22	2.6	
2,500	1/2 - 13	0.88	1.22	3/4	0.78	46008	2.31	4.78	46644	4.25	6.72	3.52	1.99	28	2.6	
2,500	1/2 - 13	0.88	1.22	3/4	1.03	46010	2.31	4.78	46646	4.25	6.72	3.52	1.99	28	2.6	
2,500	1/2 - 13	0.88	1.22	3/4	1.28	46012	2.31	4.78	46648	4.25	6.72	3.52	1.99	28	2.6	
4,000	5/8 - 11	0.88	1.22	3/4	0.78	46002	2.18	4.78	-	-	-	3.52	1.99	60	2.6	
4,000	5/8 - 11	0.88	1.22	3/4	1.03	46004	2.18	4.78	46640	4.12	6.72	3.52	1.99	60	2.6	
4,000	5/8 - 11	0.88	1.22	3/4	1.28	46006	2.18	4.78	46642	4.12	6.72	3.52	1.99	60	2.6	
5,000	3/4 - 10	0.88	1.22	3/4	1.03	46014	2.06	4.78	46650	4.00	6.72	3.52	1.99	100	3.0	
5,000	3/4 - 10	0.88	1.22	3/4	1.53	46018	2.06	4.78	46654	4.00	6.72	3.52	1.99	100	3.0	
7,000	3/4 - 10	1.40	1.71	1	1.04	46204	3.06	6.52	46658	4.65	8.11	5.14	3.00	100	7.0	
7,000	3/4 - 10	1.40	1.71	1	2.54	46206	3.06	6.52	46660	4.65	8.11	5.14	3.00	100	7.0	
8,000	7/8 - 9	1.40	1.71	1	1.04	46202	2.93	6.52	46656	4.52	8.11	5.14	3.00	160	7.0	
8,000	7/8 - 9	1.40	1.71	1	1.29	46203	2.93	6.52	46652	4.52	8.11	5.14	3.00	160	7.0	
10,000	1 - 8	1.40	1.71	1	1.29	46210	2.81	6.52	46662	4.40	8.11	5.14	3.00	230	7.5	
10,000	1 - 8	1.40	1.71	1	1.54	46212	2.81	6.52	46664	4.40	8.11	5.14	3.00	230	7.5	
10,000	1 - 8	1.40	1.71	1	2.29	46214	2.81	6.52	46666	4.40	8.11	5.14	3.00	230	7.5	
15,000	1-1/4 - 7	1.75	2.11	1-1/4	1.89	46802	4.12	8.73	-	-	-	6.50	3.76	470	14.0	
20,000	1-3/8 - 6	2.00	2.36	1-1/2	2.64	46702	5.20	10.59	-	-	-	7.46	4.31	540	22.0	
24,000	1-1/2 - 6	2.25	2.81	1-3/4	2.70	46404	6.41	12.47	-	-	-	8.55	4.87	800	34.0	
24,000	1-3/4 - 5	2.25	2.81	1-3/4	2.70	46408	6.41	12.47	-	-	-	8.55	4.87	800	34.0	
30,000	2 - 4-1/2	2.25	2.81	1-3/4	2.96	46400	5.91	12.47	-	-	-	8.55	4.87	800	36.0	
50,000	2-1/2 - 8	3.00	4.09	2-1/4	4.00	47002	8.03	16.87	-	-	-	11.67	6.52	2100	88.0	
50,000	2-1/2 - 4	3.00	4.09	2-1/4	4.00	47006	8.03	16.87	-	-	-	11.67	6.52	2100	88.0	
75,000	3 - 4	3.75	5.27	2-3/4	4.20	47200	8.48	19.50	-	-	-	14.15	8.10	4300	166.0	
100,000	3-1/2 - 4	4.00	6.06	3-1/4	7.00	47402	9.28	22.09	-	-	-	15.90	8.60	5100	265.0	
250,000	6 - 4	6.00	14.00	5	9.00	47602	14.00	33.00	-	-	-	25.00	13.00	9900	790.0	

- Rated load from 400 lbs. to 125 tons
- Pivots 180° / Swivels 360°
- Material: AISI 4140 aircraft quality
- Finish: Black oxide per mil spec cadmium plated
- Safety factor: 5:1
- 100% magnetic particle inspected
- Certified heat treatment

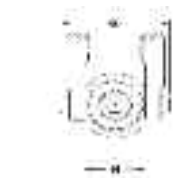

METRIC THREADS

Rated Loads (Kgs)	Thread Size	A	C	D	E	Standard U-Bar			Long U-Bar			G	H	Torque Kgm	Wt. (Kgs)
						Part No.	B	F	Part No.	B	F				
400	M8 x 1.25	11	18	10	13	46912	32	68	-	-	-	47	25	0.86	0.17
500	M10 x 1.50	11	18	10	18	46916	30	68	-	-	-	47	25	1.5	0.17
1,050	M12 x 1.75	22	30	19	19	46924	60	121	47124	110	171	89	51	3.7	1.08
1,900	M16 x 2.00	22	30	19	29	46930	56	121	47130	106	171	89	51	8.4	1.12
2,150	M20 x 2.50	22	30	19	34	46936	52	121	47136	102	171	89	51	14	1.19
3,000	M20 x 2.50	36	43	25	32	46942	78	166	47142	118	206	131	76	14	3.03
4,200	M24 x 3.00	36	43	25	37	46948	74	166	47148	114	206	131	76	14	3.10
4,200	M30 x 3.50	36	43	25	58	-	-	-	46950	108	206	131	76	60	3.10
7,000	M30 x 3.50	45	54	32	42	46956	106	222	-	-	-	165	95	60	6.30
7,000	M30 x 3.50	45	54	32	62	46958	106	222	-	-	-	165	95	60	6.40
11,000	M36 x 4.00	57	71	44	64	46966	166	317	-	-	-	217	124	100	15.50
12,500	M42 x 4.50	57	71	44	82	46968	160	317	-	-	-	217	124	100	16.00
13,500	M48 x 5.00	57	71	44	82	46970	154	317	-	-	-	217	124	100	16.80
22,300	M64 x 6.00	76	103	57	101	46972	204	428	-	-	-	296	165	273	39.00
31,500	M72 X 6.00	95	133	70	132	46988	220	495	-	-	-	359	206	559	74.00
51,000	M90 x 6.00	102	153	83	177	46990	235	561	-	-	-	404	218	663	118.00

Side Load Hoist Rings - Acteck™

Part No.	Rated Load (lbs)	Thread Size	Dimensions (in)							Torque (ft/ lbs)	Wt. (lbs)
			A	B	C	D	E	F	G		
43510	650	5/16 - 18	2	1-1/2	1-7/16	3/8	5/8	1-15/16	3/8	3.5	1/4
43515	800	3/8 - 16	2	1-1/2	1-7/16	3/8	3/4	1-15/16	3/8	4.5	1/4
43520	1,800	1/2 - 13	3	2-3/8	2-1/4	5/8	1	3	1/2	15	3-1/4
43525	2,500	5/8 - 11	3	2-3/8	2-1/4	5/8	1-1/4	3	1/2	25	3-1/4
43530	4,000	3/4 - 10	4	3-3/4	3-3/8	1	1-1/2	4-1/2	3/4	50	11-1/4
43535	5,500	7/8 - 9	4	3-3/4	3-3/8	1	2	4-1/2	3/4	80	11-1/4
43540	7,000	1 - 8	4	3-3/4	3-3/8	1	2	4-1/2	3/4	90	11-1/2
43545	14,000	1-1/4 - 7	6	4-5/8	4-5/8	1-3/8	2	6-1/4	1	150	27-3/4
43550	17,000	1-1/2 - 6	6	4-5/8	4-5/8	1-3/8	2-1/2	6-1/4	1	250	31-1/2
43555	29,000	2 - 4-1/2	5-1/4 x 10-1/2	4-5/8	6-5/8	1-1/2	3-1/8	11-1/8	1	300	42

- Designed for side-mount applications
- Swivels 360°/Pivots 180°
- Extra large ring accepts many styles & sizes of hoist hooks
- Ideal for stamping & injection mold industries
- Rated loads from 650 lbs. to 29,000 lbs.
- Material: 4140 Certified aircraft quality
- Finish: Black oxide per mil spec. (cadmium plated available).
- Safety Factor: 5:1
- Magnetic particle inspected
- Certified heat treatment

METRIC Side Load Hoist Rings

Part No.	Rated Load (kgs)	Thread Size	Dimensions (mm)							Torque (ft/lbs)	Wt. (lbs)
			A	B	C	D	E	F	G		
43560	325	M8 x 1.25	2	1-1/2	1-7/16	3/8	16	1-15/16	3/8	3.5	1/4
43565	500	M10 x 1.50	2	1-1/2	1-7/16	3/8	20	1-15/16	3/8	4.5	1/4
43570	725	M12 x 1.75	3	2-3/8	2-1/4	5/8	24	3	1/2	15	3-1/4
43575	1,400	M16 x 2.00	3	2-3/8	2-1/4	5/8	31	3	1/2	25	3-1/4
43580	2,290	M20 x 2.50	4	3-3/4	3-3/8	1	40	4-1/2	3/4	50	11-1/4
43585	3,050	M24 x 3.00	4	3-3/4	3-3/8	1	47	4-1/2	3/4	80	11-1/4
43590	4,850	M30 x 3.50	6	4-5/8	4-5/8	1-3/8	44	6-1/4	1	150	27-3/4

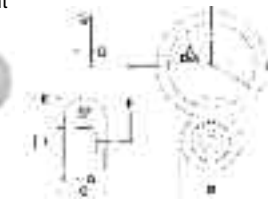

Hoist Rings

Stainless Steel Safety Hoist Rings - Actek™

Rated Loads (lbs)	Thread Size (in)	A	C	D	E	Standard U-Bar			Long U-Bar			G	H	Torque (ft/#)	Wt. (lbs)	
						Part No.	B	F	Part No.	B	F					
UNC THREADS																
400	5/16 - 18	0.43	0.71	3/8	0.29	58102	1.27	2.67	-	-	-	1.84	1.00	3.5	0.3	
400	5/16 - 18	0.43	0.71	3/8	0.54	58104	1.27	2.67	-	-	-	1.84	1.00	3.5	0.3	
500	3/8 - 16	0.43	0.71	3/8	0.54	58106	1.27	2.67	-	-	-	1.84	1.00	6	0.3	
1,250	1/2 - 13	0.70	0.93	1/2	1.07	58602	1.84	3.77	-	-	-	2.58	1.49	14	1.0	
1,250	1/2 - 13	0.88	1.22	3/4	0.78	58008	2.31	4.78	58644	4.25	6.72	3.52	1.99	14	2.6	
1,250	1/2 - 13	0.88	1.22	3/4	1.03	58010	2.31	4.78	58646	4.25	6.72	3.52	1.99	14	2.6	
1,250	1/2 - 13	0.88	1.22	3/4	1.28	58012	2.31	4.78	58648	4.25	6.72	3.52	1.99	14	2.6	
2,000	5/8 - 11	0.88	1.22	3/4	0.78	58002	2.18	4.78	-	-	-	3.52	1.99	30	2.6	
2,000	5/8 - 11	0.88	1.22	3/4	1.03	58004	2.18	4.78	58640	4.12	6.72	3.52	1.99	30	2.6	
2,000	5/8 - 11	0.88	1.22	3/4	1.28	58006	2.18	4.78	58642	4.12	6.72	3.52	1.99	30	2.6	
2,500	3/4 - 10	0.88	1.22	3/4	1.03	58014	2.06	4.78	58650	4.00	6.72	3.52	1.99	50	3.0	
2,500	3/4 - 10	0.88	1.22	3/4	1.53	58018	2.06	4.78	58654	4.00	6.72	3.52	1.99	50	3.0	
3,500	3/4 - 10	1.40	1.71	1	1.04	58204	3.06	6.52	58658	4.65	8.11	5.14	3.00	50	7.0	
3,500	3/4 - 10	1.40	1.71	1	2.54	58206	3.06	6.52	58660	4.65	8.11	5.14	3.00	50	7.0	
4,000	7/8 - 9	1.40	1.71	1	1.04	58202	2.93	6.52	58656	4.52	8.11	5.14	3.00	80	7.0	
4,000	7/8 - 9	1.40	1.71	1	1.29	58203	2.93	6.52	58652	4.52	8.11	5.14	3.00	80	7.0	
5,000	1 - 8	1.40	1.71	1	1.29	58210	2.81	6.52	58662	4.40	8.11	5.14	3.00	115	7.5	
5,000	1 - 8	1.40	1.71	1	1.54	58212	2.81	6.52	58664	4.40	8.11	5.14	3.00	115	7.5	
5,000	1 - 8	1.40	1.71	1	2.29	58214	2.81	6.52	58666	4.40	8.11	5.14	3.00	115	7.5	
7,500	1-1/4 - 7	1.75	2.11	1-1/4	1.89	58802	4.12	8.73	-	-	-	6.50	3.76	235	14.0	
12,000	1-1/2 - 6	2.25	2.81	1-3/4	2.70	58404	6.41	12.47	-	-	-	8.55	4.87	400	34.0	
15,000	2 - 4-1/2	2.25	2.81	1-3/4	2.96	58400	5.91	12.47	-	-	-	8.55	4.87	400	36.0	
25,000	2-1/2 - 8	3.00	4.09	2-1/4	4.00	59002	8.03	16.87	-	-	-	11.67	6.52	1050	88.0	
25,000	2-1/2 - 4	3.00	4.09	2-1/4	4.00	59006	8.03	16.87	-	-	-	11.67	6.52	1050	88.0	
37,500	3 - 4	3.75	5.27	2-3/4	4.20	59200	8.48	19.50	-	-	-	14.15	8.10	2150	66.0	
50,000	3-1/2 - 4	4.00	6.06	3-1/4	7.00	59402	9.28	22.09	-	-	-	15.90	8.60	2550	265.0	
METRIC THREADS																
Rated Loads (Kgs)	Thread Size	A	C	D	E	Standard U-Bar			Long U-Bar			G	H	Torque Kgm	Wt. (kgs)	
						Part No.	B	F	Part No.	B	F					
200	M8 x 1.25	11	18	10	13	58912	32	68	-	-	-	47	25	0.43	0.17	
250	M10 x 1.50	11	18	10	18	58916	30	68	-	-	-	47	25	0.75	0.17	
525	M12 x 1.75	22	30	19	19	58924	60	121	59124	110	171	89	51	1.85	1.08	
950	M16 x 2.00	22	30	19	29	58930	56	121	59130	106	171	89	51	4.2	1.12	
1,075	M20 x 2.50	22	30	19	34	58936	52	121	59136	102	171	89	51	7	1.19	
1,500	M20 x 2.50	36	43	25	32	58942	78	166	59142	118	206	131	76	7	3.03	
2,100	M24 x 3.00	36	43	25	37	58948	74	166	59148	114	206	131	76	7	3.10	
2,100	M30 x 3.50	36	43	25	58	-	-	-	58950	108	206	131	76	30	3.10	
3,500	M30 x 3.50	45	54	32	42	58956	106	222	-	-	-	165	95	30	6.30	
3,500	M30 x 3.50	45	54	32	62	58958	106	222	-	-	-	165	95	30	6.40	
5,500	M36 x 4.00	57	71	44	64	58966	166	317	-	-	-	217	124	50	15.50	
6,250	M42 x 4.50	57	71	44	82	58968	160	317	-	-	-	217	124	50	16.00	
6,750	M48 x 5.00	57	71	44	82	58970	154	317	-	-	-	217	124	50	16.80	
11,150	M64 x 6.00	76	103	57	101	58972	204	428	-	-	-	296	165	136.5	39.00	
15,750	M72 x 6.00	95	133	70	132	58988	220	495	-	-	-	359	206	279.5	74.00	
22,300	M90 x 6.00	102	153	83	177	58990	235	561	-	-	-	404	218	331.5	118.00	

- Swivels 360°/Pivots 180°
- For use in outdoor weather & certain chemical & corrosive environments
- Material: 316 Stainless Steel
- Safety Factor: 5:1
- Liquid penetrant mil 6868



4
Rigging
Fittings

Large Opening Swivel & Pivot Hoist Rings - Actek™

- Swivels 360°/Pivots 180°
- Rated loads from 800 lbs. to 10,000 lbs.
- The extra large inside diameter of this lift ring allows the user to utilize many styles & larger size hoist hooks.
- Die & mold makers will like the way this ring reacts to laying down and rolling the dies and molds over to work on them.
- Material: 4140 Certified Aircraft Quality
- Finish: Black Oxide Per Mil Spec. (Cadmium Plated Available)
- Safety Factor: 5:1
- Magnetic Particle Inspected.
- Certified Heat Treatment

Part No.	Rated Load (lbs)	Dimensions (in)						Thread Size	
		A	B	C	D	E	F		
42620	800	2	1.48	1.75	3/8	1/2	3.60	1	5/16 - 18
42630	1,000	2	1.48	1.75	3/8	5/8	3.60	1	3/8 - 16
42640	2,500	3	2.68	2.57	5/8	3/4	5.87	1-3/4	1/2 - 13
42650	4,000	3	2.68	2.57	5/8	1	5.87	1-3/4	5/8 - 11
42660	7,000	4	4.25	3.31	1	1-1/4	8.56	2-3/4	3/4 - 10
42670	10,000	4	4.25	3.31	1	1-1/2	8.56	2-3/4	1 - 8

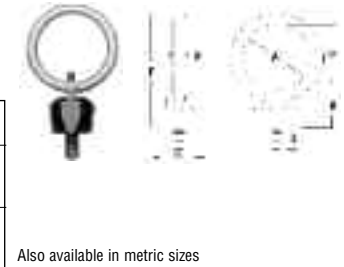

Also available in metric sizes

Safety Hoist Rings Side Pull - Actek™

- Designed for side-mounted applications.
- Smooth swiveling and pivoting action.
- Aircraft quality "chrome moly," strong and tough!
- Extra large ring accepts many styles and sizes of hoist hooks.
- For use of light to medium lifting applications.
- Good for lifting tooling fixtures, boxes or containers.
- Ideal for stamping and injection mold industries.
- Magnetic particle inspected.
- Rated loads from 1,000 lbs. to 5,000 lbs.
- Thread size from 3/8" to 3/4".
- Safety factor: 5:1.

Part No.	Rated Load (lbs)	Dimensions (in)										Torque (ft/lbs)	Rplcm. Screw
		A	B	C	D	F	G	H	J	K	R		
41106	1,000	1-3/16	5/8	1-3/16	5/8	1-1/4	13/16	3/8	3/8-16	5/8	1	9	41146
41602	2,500	1-3/4	7/8	1-3/4	1	2	1-1/4	5/8	5/8-11	3/4	1-1/2	46	41636
41014	5,000	2-1/4	1-3/16	2-3/8	1-1/4	2-1/2	1-1/2	3/4	3/4-10	1	2	75	41044
Metric Safety Hoist Rings Side Pull													
Part No.	Rated Load (lbs)	Dimensions (in)										Torque (ft/lbs)	Rplcm. Screw
		A	B	C	D	F	G	H	J	K	R		
41916	1,000	1-3/16	5/8	1-3/16	5/8	1-1/4	13/16	3/8	M10	16mm	1	9	41146M
41930	2,500	1-3/4	7/8	1-3/4	1	2	1-1/4	5/8	M16	22mm	1-1/2	46	41056M
41942	5,000	2-1/4	1-3/16	2-3/8	1-1/4	2-1/2	1-1/2	3/4	M20	26mm	2	75	41244M

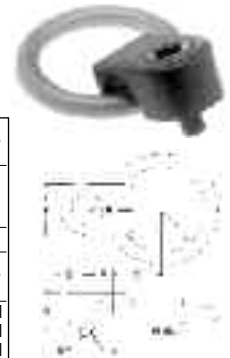

Rigging Fittings

Hoist Rings

Side Pull Hoist Rings - Crosby

HR-1200 (UNC)

WLL (lbs)	Bolt Size (in)	HR-1200 Stock No.	Each (lbs)
650	5/16 x 1.5	1067700	.43
800	3/8 x 1.5	1067704	.43
2200	1/2 x 2.0	1067708	2.49
2000	1/2 x 2.5	1067712	2.49
3000	5/8 x 2.0	1067716	2.55
3000	5/8 x 2.75	1067720	2.55
5000	3/4 x 2.75	1067724	2.65
5000	3/4 x 3.5	1067728	2.65
6500	7/8 x 2.75	1067732	7.00
6500	7/8 x 3.50	1067736	7.00
8000	1 x 3.0	1067740	7.00
8000	1 x 4.0	1067744	7.00
14000	1.25-7 x 4.5	1067748	14.8
17200	1.5-6 x 6.5	1067756	33.0
29000	2.0 x 6.5	1067764	36.0

HR-1200M (Metric)

WLL (t)	Bolt Size (mm)	HR-1200M Stock No.	Each (kgs)
.3	8	1067803	.15
.4	10	1067807	.16
1.0	12	1067811	.66
1.4	16	1067815	.68
2.25	20	1067823	2.11
3.50	24	1067827	2.19
6.25	30	1067831	4.84
7.75	36	1067835	10.75
10.0	42	1067839	11.48
13.0	48	1067843	11.50



**HR-1200 (UNC)
HR-1200M (Metric)**
Use with Standard Crosby Red Pin® Shackles (sold separately)

Pivot Lifting Plates - Actek™

- Material: 4140 Certified Aircraft Quality
- Finish: Black Oxide Per Mil Spec. (Cadmium Plated Available)
- Safety Factor: 5:1
- Magnetic Particle Inspected
- Certified Heat Treatment
- Large bail pivots 180°
- Rugged tapered plate minimizes shear force on high strength alloy screw
- Base plate can be welded into position thus eliminating use of screws
- Ideal for some OEM applications
- Rated lifting capacity from 7,000 lbs to 10,000 lbs.

- Thread engagement 1-1/2 times screw diameter.
 - Use high tensile alloy screw equivalent to grade 8.
- NOTE: To obtain maximum load capacity, high strength alloy screws must be used.

Part No.	Rated Load (lbs)	Dimensions (in)					Thread Size	Torque (ft/lbs)
		A	B	C	D	F		
44410	7,000	1.40	4-13/16	3/4	1	6-1/2	3/4 - 10	100
44610*	7,000	1.40	4-13/16	3/4	1	8-7/64	3/4 - 10	100
44415	8,000	1.40	4-13/16	7/8	1	6-1/2	7/8 - 9	160
44615*	8,000	1.40	4-13/16	7/8	1	8-7/64	7/8 - 9	160
44420	10,000	1.40	4-13/16	1	1	6-1/2	1 - 8	230
44620*	10,000	1.40	4-13/16	1	1	8-7/64	1 - 8	230

*Long Bar



Round Base Swivel & Pivot Hoist Rings - Actek™

- Material: 4140 Certified Aircraft Quality
- Finish: Black Oxide Per Mil Spec. (Cadmium Plated Available)
- Safety factor: 5:1.
- Magnetic Particle Inspected
- Certified Heat Treatment
- Swivels 360°/pivots 180°
- Direct mounting.
- Wide round base helps distribute shear loads.
- Aircraft quality "chrome moly" and heat treated.
- Rated load capacities from 2,500 lbs. to 20,000 lbs.
- Many OEM applications.

- Perfect for pre-cast concrete products: simply cast a threaded anchor or stud into the concrete part. Mount the hoist ring and you have an easy, safe lifting/handling application.
- Note. Thread engagement should be 1-1/2 times the diameter of the equivalent of Grade 8 alloy screws.

Part No.	Rated Load (lbs)	Dimensions (in)								Thread Size	Torque (ft/lbs)
		A	B	C	D	H	F	G	I		
44646	2,500	0.88	3-1/4	1-7/64	3/4	3.5	6-3/4	1/4	1/2	1/2 - 13	28
44642	4,000	0.88	3-1/4	1-7/64	3/4	3.5	6-3/4	1/4	5/8	5/8 - 11	60
44654	5,000	0.88	3-1/4	1-7/64	3/4	3.5	6-3/4	1/4	3/4	3/4 - 10	100
44660	7,000	1.40	4-13/16	1-1/2	1	5.0	8-7/64	13/32	3/4	3/4 - 10	100
44656	8,000	1.40	4-13/16	1-1/2	1	5.0	8-7/64	13/32	7/8	7/8 - 9	160
44666	10,000	1.40	4-13/16	1-1/2	1	5.0	8-7/64	13/32	1	1 - 8	230
44802	15,000	1.75	6	1-7/8	1-1/4	7.0	8-3/4	1/2	1-1/4	1-1/4 - 7	470
44704	20,000	2.00	7-11/32	2	1-1/2	7.0	10-7/64	1/2	1-1/2	1-1/2 - 6	800



Swivel & Pivot Rectangular Plate Hoist Rings - Actek™

- Material: 4140 Certified Aircraft Quality
- Finish: Black Oxide Per Mil Spec. (Cadmium Plated Available)
- Safety factor: 5:1.
- Magnetic Particle Inspected
- Certified Heat Treatment
- Large base plate disburses shear loads for safer lifting.
- Swivels 360°/pivots 180°.
- Generous ball opening.
- Aircraft quality "chrome moly" and heat treated.
- Rated load capacities from 2,500 lbs. to 10,000 lbs.
- Perfect for pre-cast concrete products: simply cast a threaded anchor or stud into the concrete part. Mount the hoist ring and you have an easy, safe lifting/handling application.

Part No.	Rated Load (lbs)	Dimensions (in)						Thread Size	Torque (ft/lbs)
		A	B	C	D	E	F		
41032	2,500	0.88	3-1/4	3.0	3/4	3/4	4-3/4	1/2 - 13	28
41632*	2,500	0.88	3-1/4	4.9	3/4	3/4	6-3/4	1/2 - 13	28
41034	4,000	0.88	3-1/4	2.9	3/4	1	4-3/4	5/8 - 11	60
41634*	4,000	0.88	3-1/4	4.8	3/4	1	6-3/4	5/8 - 11	60
41036	5,000	0.88	3-1/4	2.8	3/4	1-1/4	4-3/4	3/4 - 10	100
41636*	5,000	0.88	3-1/4	4.7	3/4	1-1/4	6-3/4	3/4 - 10	100
41242	7,000	1.40	4-13/16	4.0	1	1-1/4	6-1/2	3/4 - 10	100
41642*	7,000	1.40	4-13/16	5.6	1	1-1/4	8-7/64	3/4 - 10	100
41244	8,000	1.40	4-13/16	3.9	1	1-1/2	6-1/2	7/8 - 9	160
41644*	8,000	1.40	4-13/16	5.5	1	1-1/2	8-7/64	7/8 - 9	160
41246	10,000	1.40	4-13/16	3.8	1	1-1/2	6-1/2	1 - 8	230
41646*	10,000	1.40	4-13/16	5.4	1	1-1/2	8-7/64	1 - 8	230



* Long Bar

Hoist Rings/Eye Bolts

Speed Base Hoist Rings - Actek™

No Wrenches Required! Just spin the base down flush and tap one of the lugs to tighten. Simple and Fast!

- Swivels 360°/Pivots 180°
- Material: AISI 4140 Aircraft Quality Chrome Moly
- Finish: Black Oxide
- Safety Factor: 5:1

- Magnetic Particle Inspected
- Certified Heat Treated

Part No.	Rated Load (lbs)	Thread Size (in)	Effective Thread Length
AK42002	2,500	1/2 - 13	1
AK42004	4,000	5/8 - 11	1
AK42006	5,000	3/4 - 10	1.25
AK42202	7,000	3/4 - 10	1.25
AK42204	8,000	7/8 - 9	1.50
AD42206	10,000	1 - 8	1.50



Tap the lugs with a small hammer or "tapper" to make sure base is tight on the surface of the object being lifted.

Street Plate Lifting Rings - Actek™

- Swivels 360°/pivots 180°.
- Material: 4140 Certified Aircraft Quality
- Finish: Black Oxide Per Mil Spec. (Cadmium Plated Available)
- Safety Factor: 5:1
- Steel trench plates are used to cover trenches in streets and roadways in order to facilitate traffic flow during construction or repair.
- Street Plate Lifting Ring lugs are used for tightening and loosening with hammer or steel bar.
- Certified Heat Treatment
- Magnetic Particle Inspected

Part No.	Rated Load (lbs)	Dimensions (in)						Thread Type	Thread Size	Torque (ft/lbs)
		A	B	C	D	E	F			
48215	10,000	1.40	4-13/16	4-3/8	1	3/4	8-7/64	Coil	1-1/4	230
48225	10,000	1.40	4-13/16	4-3/8	1	1-1/2	8-7/64	Coil	1-1/2	470
48235	10,000	1.40	4-13/16	4-3/8	1	3/4	8-7/64	Acme	1-1/4	230
48245	10,000	1.40	4-13/16	4-3/8	1	1-1/2	8-7/64	Acme	1-1/2	470
48865	15,000	1.75	6	4-1/4	1-1/4	3/4	8-3/4	Coil	1-1/4	230
48875	15,000	1.75	6	4-1/4	1-1/4	1-1/2	8-3/4	Coil	1-1/2	470
48885	15,000	1.75	6	4-1/4	1-1/4	3/4	8-3/4	Acme	1-1/4	230
48895	15,000	1.75	6	4-1/4	1-1/4	1-1/2	8-3/4	Acme	1-1/2	470



Street Plate Coil Nut - Actek™

- Material: 4140 Certified Aircraft Quality
- Certified Heat Treatment
- Welding Rod-Alloy #7018



Regular Nut and Shoulder Nut Eye Bolt - Installation for In-line Loading

Operating Safety

- Always stand clear of load.
- Always lift load with steady, even pull - do not jerk.
- Always apply load to eye bolt in the plane of the eye, not at an angle.
- Never exceed the capacity of the eye bolt-see Table 1.
- When using lifting slings of two or more legs, make sure the loads in the legs are calculated using the angle from the vertical to the leg and properly size the shoulder nut or machinery eye bolt for the angular load.

Right

More than one eye bolt dia. of threads, only (1) nut required.

Tighten hex nut securely against load

Right

One eye bolt dia. of threads or less, use two (2) nuts.

Tighten hex nut securely against load

Right

Tighten Hex Nut Securely Against Load

Tap Depth: 2.5 x Dia. (Min.)

2x Dia. (Min.)

Wrong

One eye bolt dia. or less

Wrong

Do not reeve slings from one eye bolt to another. This will alter the load & angle of loading on the eye bolt.

Resultant Load

Wrong

After slings have been properly attached to the eye bolts, apply force slowly. Watch the load carefully & be prepared to stop applying force if the load starts buckling.

Buckling may occur if the load is not stiff enough to resist the compressive forces which result from the angular loading.

Machinery Eye Bolt - Installation for In-Line and Angular Loading

These eye bolts are primarily intended to be installed into tapped holes.

1. After the loads on the eye bolts have been calculated, select the proper size eye bolt for the job. For angular lifts, adjust working load as follows:

Direction of Pull	Adjusted Working Load
45 degrees	30% of rated working load
90 degrees	25% of rated working load

2. Drill and tap the load to the correct sizes to a minimum depth of one-half the eye bolt size beyond the shank length of the machinery eye bolt.

3. Thread the eye bolt into the load until the shoulder is flush and securely tightened against the load.
4. If the plane of the machinery eye bolt is not aligned with the sling line, estimate the amount of unthreading rotation necessary to align the plane of the eye properly.
5. Remove the machinery eye bolt from the load and add shims (washers) of proper thickness to adjust the angle of the plane of the eye to match the sling line. Use Table 2 to estimate the required shim thickness for the amount of unthreading rotation required.

Shim added to change eye alignment 90°

Min. tap depth is basic shank length plus one-half the nominal eye bolt dia.

Eye Bolt Size (in)	Shim Tkness. Required to Change Rotation 90° (in)
1/4	.0125
5/16	.0139
3/8	.0156
1/2	.0192
5/8	.0227
3/4	.0250
7/8	.0278
1	.0312
1-1/4	.0357
1-1/2	.0417

Rigging Fittings

Eye Bolts

Forged Eye Bolt - Warnings & Applications

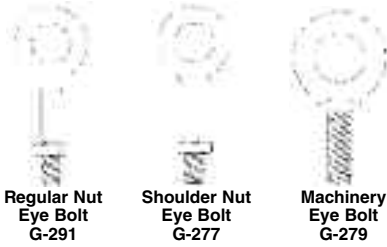

Inspection/Maintenance Safety:

- Always inspect eye bolt before use.
- Never use eye bolt that shows signs of wear or damage.
- Never use eye bolt if eye or shank is bent or elongated.
- Always be sure threads on shank and receiving holes are clean.
- Never machine, grind, or cut eye bolt.

Assembly Safety:

- Never exceed load limits specified in Table 1.
- Never use regular nut eye bolts for angular lifts.
- Always use shoulder nut eye bolts (or machinery eye bolts) for angular lifts.
- For angular lifts, adjust working load as follows:

Direction of Pull	Adjusted Working Load
45 degrees	30% of rated working load
90 degrees	25% of rated working load

- Never undercut eye bolt to seat shoulder against the load.
- Always countersink receiving hole or use washers to seat shoulder.
- Always screw eye bolt down completely for proper seating.
- Always tighten nuts securely against the load.

! WARNING !

- Loads may slip or fall if proper eye bolt assembly and lifting procedures are not used.
- A falling load can seriously injure or kill.
- Read and understand both sides of these instructions, and follow all eye bolt safety information presented here.
- Read, understand, and follow information in diagrams and charts below before using eye bolt assemblies.

Size (in)	WLL (lbs)
1/4	500
5/16	800
3/8	1,200
1/2	2,200
5/8	3,500
3/4	5,200
7/8	7,200
1	10,000
1-1/4	15,200
1-1/2	21,400

Shoulder Nut Eye Bolt – Installation for Angular Loading

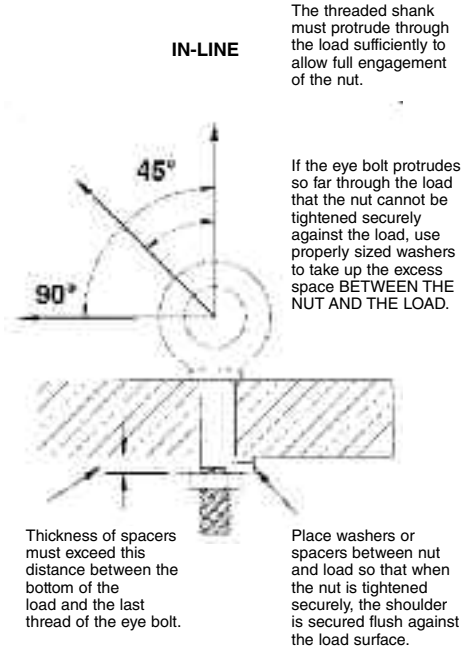

4 Rigging Fittings

Regular Nut Eye Bolts (Forged)

Crosby® G-291



- Recommended for straight line pull.
- All bolts Hot Dip galvanized after threading (UNC).
- Furnished with standard Hot Dip galvanized hex nuts.
- Forged Steel-Quenched and Tempered.
- Fatigue rated at 1-1/2 times the Working Load Limit at 20,000 cycles.

Shank Dia. & Length (in)	Length of Thread (in)	Inside Dia. of Eye (in)	WLL (lbs)	Wt. Per 100 (lbs)
1/4 x 2	1-1/2	1/2	500	6.00
1/4 x 4	2-1/2	1/2	500	12.50
5/16 x 2-1/4	1-1/2	5/8	800	18.75
5/16 x 4-1/4	2-1/2	5/8	800	25.00
3/8 x 2-1/2	1-1/2	3/4	1,200	31.25
3/8 x 4-1/2	2-1/2	3/4	1,200	37.50
3/8 x 6	2-1/2	3/4	1,200	43.75
1/2 x 3-1/4	1-1/2	1	2,200	50.00
1/2 x 6	3	1	2,200	62.50
1/2 x 8	3	1	2,200	75.00
1/2 x 10	3	1	2,200	88.00
1/2 x 12	3	1	2,200	100.00
5/8 x 4	2	1-1/4	3,500	101.25
5/8 x 6	3	1-1/4	3,500	125.00
5/8 x 8	3	1-1/4	3,500	150.00
5/8 x 10	3	1-1/4	3,500	162.50
5/8 x 12	4	1-1/4	3,500	175.00
3/4 x 4-1/2	2	1-1/2	5,200	156.00
3/4 x 6	3	1-1/2	5,200	160.00
3/4 x 8	3	1-1/2	5,200	200.00
3/4 x 10	3	1-1/2	5,200	238.00
3/4 x 12	4	1-1/2	5,200	252.00
3/4 x 15	5	1-1/2	5,200	300.00
7/8 x 5	2-1/2	1-3/4	7,200	275.00
7/8 x 8	4	1-3/4	7,200	325.00
7/8 x 12	4	1-3/4	7,200	400.00
1 x 6	3	2	10,000	425.00
1 x 9	4	2	10,000	452.00
1 x 12	4	2	10,000	550.00
1 x 18	7	2	10,000	650.00
1-1/4 x 8	4	2-1/2	15,200	750.00
1-1/4 x 12	4	2-1/2	15,200	900.00
1-1/4 x 20	6	2-1/2	15,200	1,150.00

Shoulder Nut Eye Bolts (Forged)

Crosby® G-277

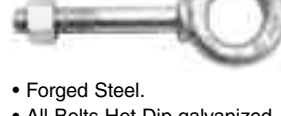

- Forged Steel.
- All Bolts Hot Dip galvanized after threading (UNC).
- Furnished with standard Hot Dip galvanized, heavy hex nuts.
- Fatigue rated at 1-1/2 times the Working Load Limit at 20,000 cycles.

Shank Dia. & Length (in)	Length of Thread (in)	Inside Dia. of Eye (in)	WLL (lbs)	Wt. Per 100 (lbs)
1/4 x 2	1-1/2	1/2	500	3.75
1/4 x 4	2-1/2	1/2	500	6.25
5/16 x 2-1/4	1-1/2	5/8	800	12.50
5/16 x 4-1/4	2-1/2	5/8	800	18.75
3/8 x 2-1/2	1-1/2	3/4	1,200	19.00
3/8 x 4-1/2	2-1/2	3/4	1,200	31.58
1/2 x 3-1/4	1-1/2	1	2,200	37.50
1/2 x 6	3	1	2,200	56.25
5/8 x 4	2	1-1/4	3,500	75.00
5/8 x 6	3	1-1/4	3,500	100.25
3/4 x 4-1/2	2	1-1/2	5,200	125.00
3/4 x 6	3	1-1/2	5,200	150.00
7/8 x 5	2-1/2	1-3/4	7,200	225.00
7/8 x 8	4	1-3/4	7,200	275.00
1 x 6	3	2	10,000	375.00
1 x 9	4	2	10,000	425.00
1-1/4 x 8	4	2-1/2	15,200	650.00
1-1/4 x 12	4	2-1/2	15,200	775.00
1-1/2 x 15	6	3	21,400	1,425.00

Screw Eye Bolts (Forged)

Crosby® G-275

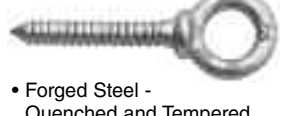

- Forged Steel - Quenched and Tempered.
- Hot Dip galvanized

Shank Dia. & Length (in)	Length of Thread (in)	Inside Dia. of Eye (in)	WLL (lbs)	Wt. Per 100 (lbs)
1/4 x 2	1.50	.50	500	4.30
5/16 x 2-1/4	1.69	.63	800	9.90
3/8 x 2-1/2	1.88	.75	1,200	18.88
1/2 x 3-1/4	2.44	1.00	2,200	37.50
5/8 x 4	3.00	1.25	3,500	85.50



Eye Bolts

Machine Eye Bolts

Plain Pattern

- Forged
- 1030 Carbon Steel, Self-Colored

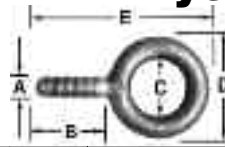

Stock No.	Thread Size UNC-2A A	Shank Length B	I.D. Eye C	O.D. Eye D	Overall Length E	Blanks*	Approx. Wt. Per 100 Pcs. (lbs)	Rated Cap. (lbs)
13611	1/4 - 20	1	3/4	1-3/16	2-7/32	R13611	4.9	500
13621	5/16 - 18	1-1/8	7/8	1-7/16	2-19/32	R13621	8.5	900
13631	3/8 - 16	1-1/4	1	1-11/16	3	R13631	14.0	1,300
13638	7/16 - 14	1-3/8	1-3/32	1-13/16	3-7/32	R13638	19.0	1,800
13641	1/2 - 13	1-1/2	1-3/16	2-1/8	3-21/32	R13641	29.5	2,400
13650	9/16 - 12	1-3/4	1-3/8	2-9/16	4-3/8	R13650	44.0	3,200
13661	5/8 - 11	1-3/4	1-3/8	2-9/16	4-3/8	R13661	58.0	4,000
13672	3/4 - 10	2	1-1/2	2-13/16	4-7/8	R13672	88.5	5,000
13682	7/8 - 9	2-1/4	1-11/16	3-3/16	5-1/2	R13682	129.0	7,000
13702	1 - 8	2-1/2	1-13/16	3-9/16	6-1/8	R13702	198.5	9,000
13712	1-1/8 - 7	2-3/4	2	4-1/16	6-7/8	R13712	292.0	12,000
13723	1-1/4 - 7	3	2-13/16	4-7/16	7-1/2	R13723	396.0	15,000
13753	1-1/2 - 6	3-1/2	2-1/2	5-3/16	8-3/4	R13753	654.0	21,000
13770	1-3/4 - 5	3-3/4	2-7/8	6	9-13/16	R13770	1050.0	28,000
13780	2 - 4-1/2	4	3-1/4	6-7/8	11	R13780	1580.0	38,000
13790	2-1/2 - 4	5	4	8-1/2	13-5/8	-	2900.0	56,000

Part #13650 dimensions not in accordance with ANSI B18.15.

Machine Eye Bolts

Shoulder Pattern

- Forged
- 1030 Carbon Steel, Self-Colored



Stock No.	Thread size UNC-2A A	Shank Length B	I.D. Eye C	O.D. Eye D	Overall Length E	Center of Eye to Shoulder F	Blanks*	Approx. Wt. Per 100 Pcs. (lbs)	Rated Cap. (lbs)
14611	1/4 - 20	1	3/4	1-3/16	2-3/8	3/4	R14611	5.0	500
14621	5/16 - 18	1-1/8	7/8	1-7/16	2-13/16	15/16	R14621	9.6	900
14631	3/8 - 16	1-1/4	1	1-11/16	3-1/4	1-1/8	R14631	16.0	1,300
14638	7/16 - 14	1-3/8	1-3/32	1-13/16	3-9/16	1-1/4	R14638	24.2	1,800
14641	1/2 - 13	1-1/2	1-3/16	2-1/8	3-31/32	1-3/8	R14641	34.8	2,400
14650	9/16 - 12	1-3/4	1-3/8	2-9/16	4-3/4	1-21/32	R14650	47.0	3,200
14661	5/8 - 11	1-3/4	1-3/8	2-9/16	4-3/4	1-21/32	R14661	67.0	4,000
14672	3/4 - 10	2	1-1/2	2-13/16	5-1/4	1-13/16	R14672	100.0	5,000
14682	7/8 - 9	2-1/4	1-11/16	3-3/16	6	2-1/8	R14682	163.0	7,000
14702	1 - 8	2-1/2	1-13/16	3-9/16	6-5/8	2-5/16	R14702	222.0	9,000
14712	1-1/8 - 7	2-3/4	2	4-1/16	7-17/32	2-11/16	R14712	340.0	12,000
14723	1-1/4 - 7	3	2-13/16	4-7/16	8-7/32	2-15/16	R14723	444.0	15,000
14753	1-1/2 - 6	3-1/2	2-1/2	5-3/16	9-15/32	3-5/16	R14753	736.0	21,000
14770	1-3/4 - 5	3-3/4	2-7/8	6	10-13/16	4	R14770	1135.0	28,000
14780	2 - 4-1/2	4	3-1/4	6-7/8	11-7/8	4-3/8	R14780	1670.0	38,000

Part #14650 dimensions not in accordance with ANSI B18.15.
*Blanks have no rated capacity.

Reduced Lifting Eye Bolts

- Forged
- 1030 Carbon-Steel, Self-Colored
- Forged from special bar quality fine grain Domestic carbon steel.
- Normalized prior to machining.
- Heat treated for strength and desired properties.
- Roll threads 1/4" thru 1-1/2".
- Cut threads 1-3/4" thru 2-1/2".
- ASTM A489 test data available on request.
- Shoulder style lifting eye 1/4" thru 1" military style collar-MS51937 specification.

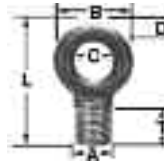

Stock No.	Dimensions (in)						Blank No.	Approx. Wt. Per 100 Pcs. (lbs)	Rated Cap. (lbs)
	A	B	C	D	L	T			
13900	1-1/4	2-3/4	1-1/2	5/8	4-5/32	7/8 min.	R13900	109	8,000
13905	1-1/2	3-1/2	1-7/8	13/16	5-3/16	1-1/16 min.	R13905	216	13,750
13910	2	4-1/8	2-1/8	31/32	6-9/16	1-7/16 min.	R13910	440	20,000
13915	2-1/2	4-3/4	2-1/2	1-1/8	7-3/4	1-7/8 min.	R13915	695	28,000

Minimum breaking strengths are based on vertical loading and verified by actual physical testing of samples chosen via random selection from each heat lot of a size produced. Actual breaking tests are performed on sample specimens.

Machinery lifting eyes manufactured and tested in accordance with ASTM A489 and ANSI B18.15.

Metric Lifting Eye Bolts

Stock No.	Metric Size	Approx. Equiva-lent in (in)	Thread Size A	Shank Length B	I.D. Eye C	O.D. Eye D	Overall Length E	Center of Eye to Shoulder F	Approx. Wt. per 100 pcs. (lbs)	Rated Cap. (lbs)
14611M	M6	1/4	M6 x 1.0	25.4	19	30.0	60.3	18.5	4.7	210
14621M	M7	5/16	M7 x 1.0	28.5	22	36.5	71.4	23.2	9.0	370
14631M	M8	3/8	M8 x 1.25	31.7	25	43.0	82.5	27.8	15.2	500
14638M	M10	7/16	M10 x 1.5	35.0	27	46.0	90.5	30.9	23.0	740
14641M	M12	1/2	M12 x 1.75	38.0	30	54.0	100.8	34.0	33.0	1,030
14661M	M14	9/16	M14 x 2.0	44.5	35	65.0	120.7	40.9	63.6	1,600
14662M	M16	5/8	M16 x 2.0	44.5	35	65.0	120.7	40.9	63.6	1,600
14672M	M18	3/4	M18 x 2.5	51.0	38	71.5	133.3	44.7	96.0	2,140
14682M	M20	7/8	M20 x 2.5	57.0	41	81.0	152.4	52.5	155.0	2,860
14702M	M24	1	M24 x 3.0	63.5	44	90.4	168.3	57.1	211.0	3,850
14712M	M27	1-1/8	M27 x 3.0	70.0	51	103.0	191.3	66.5	323.0	5,200
14723M	M30	1-1/4	M30 x 3.5	76.0	55	112.7	208.8	72.7	422.0	6,400
14753M	M36	1-1/2	M36 x 4.0	89.0	63	131.8	240.5	81.8	700.0	8,970
14760M	M42	1-5/8	M42 x 4.5	95.0	73	152.4	274.7	101.6	1080.0	11,960
14770M	M45	1-3/4	M45 x 4.5	95.0	73	152.4	274.7	101.6	1150.0	12,720
14775M	M48	1-7/8	M48 x 5.0	101.6	82	174.6	301.6	111.0	1580.0	16,400
14780M	M52	2	M52 x 5.0	101.6	82	174.6	301.6	111.0	1710.0	17,300

*Plain Pattern available upon request. All dimensions are in mm.

- Forged
- 1030 Carbon Steel Self-Colored
- Shoulder Pattern*

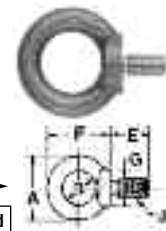
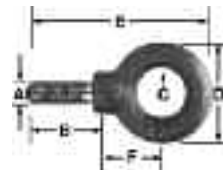

Metric Lifting Eye Bolts

Stock No.	Metric Size	Dimensions (in)							Wt. Per 100 pcs. (lbs)	Rated Cap. (lbs)
		A*	B	C	E	F	G	J		
22010	M10	45	25	10	18	44.5	25	1.5	22.5	230
22012	M12	54	30	12	22	53	30	1.75	39.5	340
22016	M16	63	35	14	28	61.5	35	2.0	67.5	700
22020	M20	72	40	16	30	71	40	2.5	100.0	1200

All dimensions are in millimeters. * Nominal Diameter

- DIN 580 Except Heat Treated 1030 Steel

Alloy Lifting Eye Bolts

- Forged • 8620 Alloy Steel

Stock No.	Dimensions (in)						Approx. Wt. per 100 pcs. (lbs)	Wt. Cap. (lbs)
	Thread Dia. A	Shank Length B	I.D. Eye C	O.D. Eye D	Overall Length E	Center of Eye to Shoulder F		
13631LT	3/8	1-1/4	1	1-11/16	3	-	16.0	1,480
13641LT	1/2	1-1/2	1-3/16	2-1/16	3-21/32	-	34.8	2,700
13661LT	5/8	1-3/4	1-3/8	2-9/16	4-3/8	-	67.0	4,300
13672LT	3/4	2	1-1/2	2-13/16	4-7/8	-	100.0	6,400
13682LT	7/8	2-1/4	1-11/16	3-3/16	5-1/2	-	163.0	8,800
13702LT	1	2-1/2	1-13/16	3-9/16	6-1/8	-	222.0	11,600
14631LT	3/8	1-1/4	1	1-11/16	3-1/4	1-1/8	16.0	1,480
14641LT	1/2	1-1/2	1-3/16	2-1/8	3-31/32	1-3/8	34.8	2,700
14661LT	5/8	1-3/4	1-3/8	2-1/2	4-3/4	1-21/32	67.0	4,300
14672LT	3/4	2	1-1/2	2-13/16	5-1/4	1-13/16	100.0	6,400
14682LT	7/8	2-1/4	1-11/16	3-3/16	6	2-1/8	163.0	8,800
14702LT	1	2-1/2	1-13/16	3-9/16	6-5/8	2-5/16	222.0	11,600
14723LT	1-1/4	3	2-3/16	4-7/16	8-7/32	2-15/16	444.0	18,400
14753LT	1-1/2	3-1/2	2-1/2	5-3/16	9-15/32	3-5/16	736.0	26,600
14780LT	2	4	3-1/4	6-7/8	11-7/8	4-3/8	1670.0	47,600

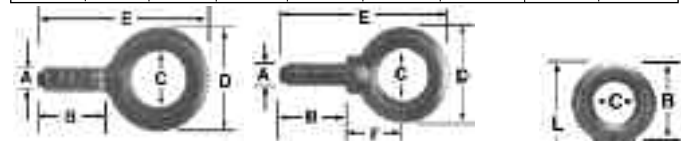

Alloy Reduced Lifting Eye Bolts

- Forged • 8620 Alloy Steel

Stock No.	Dimensions (in)						Approx. Wt. per 100 pcs. (lbs)	Rated Cap. (lbs)
	Thread Dia. A	O.D. Eye B	I.D. Eye C	Overall Length L	Thread Length T	Blanks*		
13900LT	1-1/4	2-3/4	1-1/2	4-5/32	7/8 min.	HRE 125BLK-8620	109	8,000
13905LT	1-1/2	3-1/2	1-7/8	5-3/16	1-1/16 min.	HRE 150BLK-8620	216	13,700
13910LT	2	4-1/8	2-1/8	6-9/16	1-7/16 min.	HRE 200BLK-8620	440	20,000
13915LT	2-1/2	4-3/4	2-1/2	1-3/4	1-7/8 min.	HRE 250BLK-8620	695	28,000

*Blanks have no rated capacity.

Rigging Fittings

Eye Bolts

Shoulder Type Machinery Eye Bolts (Forged)

Crosby® S-279

- Forged steel - Quenched & Tempered.
- Working Load Limits shown are for In-line pull.
- Recommended for straight line pull.
- Fatigue rated at 1-1/2 times the Working Load Limit at 20,000 cycles.
- All Bolts threaded UNC.

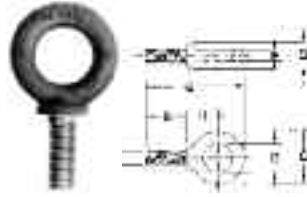

Size	S-279 Stock No.	WLL (lb)	Weight per 100 (lb)	Dimensions (in)							
				A** Thread	B	C	D	E	F	G	H
1/4 x 1	9900182	650	5.00	1/4 - 20	1.02	1.13	.75	2.29	.19	.53	.77
5/16 x 1-1/8	9900191	1200	9.00	5/16 - 18	1.15	1.38	.88	2.74	.25	.59	.95
3/8 x 1-1/4	9900208	1550	15.00	3/8 - 16	1.27	1.62	1.00	3.07	.31	.69	1.05
1/2 x 1-1/2	9900217	2600	28.00	1/2 - 13	1.53	1.95	1.19	3.70	.38	.91	1.27
5/8 x 1-3/4	9900226	5200	55.00	5/8 - 11	1.79	2.38	1.38	4.45	.50	1.13	1.53
3/4 x 2	9900235	7200	96.00	3/4 - 10	2.05	2.76	1.50	5.07	.63	1.38	1.71
7/8 x 2-1/4	9900244	10600	154.00	7/8 - 9	2.31	3.25	1.75	5.87	.75	1.56	2.00
1 x 2-1/2	9900253	13300	238.00	1 - 8	2.57	3.75	2.00	6.66	.88	1.81	2.30
1-1/8 x 2-3/4	9900257	15000	320.00	1-1/8 - 7	2.75	4.19	2.25	7.20	.97	2.06	2.35
1-1/4 x 3	9900262	21000	399.00	1-1/4 - 7	3.09	4.50	2.50	7.95	1.00	2.28	2.73
1-1/2 x 3-1/2	9900271	24000	720.00	1-1/2 - 6	3.60	5.50	3.00	9.49	1.25	2.75	3.28
1-3/4 x 3-3/4	9900280	34000	1040.00	1-3/4 - 5	3.75	6.26	3.50	10.48	1.38	3.00	3.60
2 x 4	9900289	42000	1880.00	2 - 4-1/2	4.00	7.62	4.00	12.31	1.81	3.38	4.50
2-1/2 x 5	9900298	65000	3250.00	2-1/2 - 4	5.00	8.76	4.50	14.88	2.12	4.25	5.50

* Ultimate Load is 5x the Working Load Limit. Maximum Proof Load is times the Working Load Limit. ** All bolts threaded UNC.

Shoulder Rivet Eye Bolts - Crosby® S-276

- Forged Steel - Quenched and Tempered.

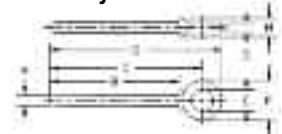

Shank Dia. & Length (in)	S-276 Stock No. S.C.	Weight per 100 (lbs)	Dimensions (in)							
			A	B	C	D	E	F	G	H
1/4 x 2	1045746	5.50	.25	2.00	2.50	2.94	.50	.88	.19	.47
1/4 x 4	1045764	7.00	.25	4.00	4.50	4.94	.50	.88	.19	.47
5/16 x 2-1/4	1045782	6.30	.31	2.25	2.94	3.50	.63	1.13	.25	.56
5/16 x 4-1/4	1045808	14.80	.31	4.25	4.94	5.50	.63	1.13	.25	.56
3/8 x 2-1/2	1045826	18.80	.38	2.50	3.28	3.97	.75	1.38	.31	.66
3/8 x 4-1/2	1045844	25.00	.38	4.50	5.28	5.97	.75	1.38	.31	.66
1/2 x 3-1/4	1045862	33.00	.50	3.25	4.25	5.12	1.00	1.75	.38	.91
1/2 x 6	1045880	50.00	.50	6.00	7.00	7.88	1.00	1.75	.38	.91
5/8 x 4	1045906	68.80	.63	4.00	5.31	6.44	1.25	2.25	.50	1.12
5/8 x 6	1045924	75.00	.63	6.00	7.31	8.44	1.25	2.25	.50	1.12
3/4 x 4-1/2	1045942	125.00	.75	4.50	6.06	7.44	1.50	2.75	.62	1.38
3/4 x 6	1045960	150.00	.75	6.00	7.56	8.94	1.50	2.75	.62	1.38
7/8 x 5	1045988	200.00	.88	5.00	6.84	8.46	1.75	3.25	.75	1.56
1 x 6	1046022	298.00	1.00	6.00	8.09	9.97	2.00	3.75	.88	1.81
1 x 9	1046040	425.00	1.00	9.00	11.09	12.97	2.00	3.75	.88	1.81
1-1/4 x 8	1046068	654.00	1.25	8.00	10.47	12.72	2.50	4.50	1.00	2.28
1-1/4 x 12	1046086	712.00	1.25	12.00	14.47	16.72	2.50	4.50	1.00	2.28
1-1/2 x 15	1046102	1425.00	1.50	15.00	18.00	20.75	3.00	5.50	1.25	2.75

Stainless Steel Eye Bolts

Plain Pattern

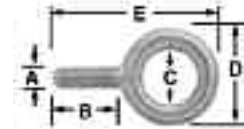

Shoulder Pattern

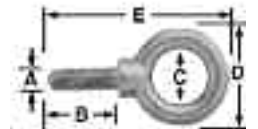

304 Stainless Steel

Stock No.	Thread Size UNC-2A A	Shank Length B	I.D. Eye C	O.D. Eye D	Overall Length E	Blanks*	Approx. Wt. per 100 pcs. (lbs)	Rated Cap. (lbs)
Plain Pattern								
SS13611	1/4-20	1	3/4	1-3/16	2-3/8	SSR13611	5.0	460
SS13621	5/16-18	1-1/8	7/8	1-7/16	2-13/16	SSR13621	9.6	780
SS13631	3/8-16	1-1/4	1	1-11/16	3	SSR13631	14.0	1,160
SS13641	1/2-13	1-1/2	1-3/16	2-1/8	3-21/32	SSR13641	29.5	2,150
SS13661	5/8-11	1-3/4	1-3/8	2-9/16	4-3/8	SSR13661	58.0	3,440
SS13672	3/4-10	2	1-1/2	2-13/16	4-7/8	SSR13672	88.5	5,140
SS13702	1-8	2-1/2	1-13/16	3-9/16	6-1/8	SSR13702	226.0	9,370
Shoulder Pattern								
SS14611	1/4-20	1	3/4	1-3/16	2-3/8	SSR14611	5.0	460
SS14621	5/16-18	1-1/8	7/8	1-7/16	2-13/16	SSR14621	9.6	780
SS14631	3/8-16	1-1/4	1	1-11/16	3-1/4	SSR14631	16.0	1,160
SS14641	1/2-13	1-1/2	1-3/16	2-1/8	3-31/32	SSR14641	34.8	2,150
SS14661	5/8-11	1-3/4	1-3/8	2-9/16	4-3/4	SSR14661	67.0	3,440
SS14672	3/4-10	2	1-1/2	2-13/16	5-1/4	SSR14672	100.0	5,140
SS14702	1-8	2-1/2	1-3/4	3-9/16	6-1/8	SSR14702	260.0	9,370

* Blanks have no rated capacity † Rated capacity - Full sized shank & eye - unaltered.

316 Stainless Steel Eye Bolt Blanks

Can be furnished threaded to your specifications

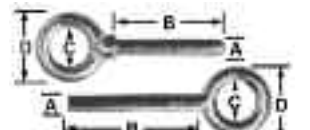

Rivet Eye Bolts - Crosby® S-293

- Forged Steel - Quenched and Tempered.

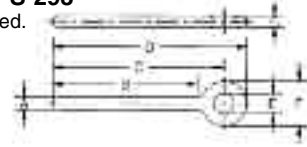

Shank Dia. & Length (in)	S-293 Stock No. S.C.	Weight per 100 (lbs)	Dimensions (in)						
			A	B	C	D	E	F	G
1/4 x 2	1043882	6.30	.25	2.00	2.63	3.13	.50	1.00	.25
1/4 x 4	1043908	11.30	.25	4.00	4.63	5.13	.50	1.00	.25
5/16 x 2-1/4	1043926	12.00	.31	2.25	3.00	3.63	.63	1.25	.31
5/16 x 4-1/4	1043944	18.30	.31	4.25	5.00	5.63	.63	1.25	.31
3/8 x 2-1/2	1043962	25.00	.38	2.50	3.38	4.13	.75	1.50	.38
3/8 x 4-1/2	1043980	27.60	.38	4.50	5.38	6.13	.75	1.50	.38
3/8 x 6	1044006	31.50	.38	6.00	6.88	7.62	.75	1.50	.38
1/2 x 3-1/4	1044024	43.80	.50	3.25	4.38	5.38	1.00	2.00	.50
1/2 x 6	1044042	62.50	.50	6.00	7.13	8.13	1.00	2.00	.50
5/8 x 4	1044060	93.80	.62	4.00	5.50	6.75	1.25	2.50	.62
5/8 x 6	1044088	113.00	.62	6.00	7.50	8.75	1.25	2.50	.62
3/4 x 4-1/2	1044104	143.80	.75	4.50	6.25	7.75	1.50	3.00	.75
3/4 x 6	1044122	162.50	.75	6.00	7.75	9.25	1.50	3.00	.75
7/8 x 5	1044140	238.00	.88	5.00	7.00	8.75	1.75	3.50	.88
7/8 x 8	1044168	291.00	.88	8.00	10.00	11.75	1.75	3.50	.88
1 x 6	1044186	375.00	1.00	6.00	8.38	10.38	2.00	4.00	1.00
1 x 9	1044202	450.00	1.00	9.00	11.38	13.38	2.00	4.00	1.00
1-1/4 x 8	1044220	720.00	1.25	8.00	10.88	13.38	2.50	5.00	1.25
1-1/4 x 12	1044248	855.00	1.25	12.00	14.88	17.38	2.50	5.00	1.25

Stock No.	Shank Dia. A	Shank Lgth. B	I.D. of Eye C	O.D. of Eye D	Approx. Wt. per 100 Pcs.	Stock No.	Shank Dia. A	Shank Lgth. B	I.D. of Eye C	O.D. of Eye D	Approx. Wt. per 100 Pcs.
Plain Pattern						Shoulder Pattern					
SSR31602	3/8	6	3/4	1-1/2	30	SSR31636	3/8	6	3/4	1-1/2	30
SSR31600	3/8	10	3/4	1-1/2	40	SSR31640	3/8	10	3/4	1-1/2	40
SSR31606	1/2	6	1	1-15/16	42	SPECIAL	3/8	AL	3/4	1-1/2	-
SSR31605	1/2	12	1	1-15/16	75	SSR31642	1/2	6	1	1-15/16	42
SPECIAL	1/2	AL	1	1-15/16	-	SSR31645	1/2	12	1	1-15/16	75
SSR31612	5/8	6	1-3/8	2-1/2	98	SPECIAL	1/2	AL	1	1-15/16	-
SSR31610	5/8	12	1-3/8	2-1/2	153	SSR31648	5/8	6	1-3/8	2-1/2	98
SPECIAL	5/8	AL	1-3/8	2-1/2	-	SSR31650	5/8	12	1-3/8	2-1/2	153
SSR31614	3/4	6	1-1/2	2-13/16	138	SPECIAL	5/8	AL	1-3/8	2-1/2	-
SSR31615	3/4	12	1-1/2	2-13/16	216	SSR31653	3/4	6	1-1/2	2-13/16	138
SPECIAL	3/4	AL	1-1/2	2-13/16	-	SSR31655	3/4	12	1-1/2	2-13/16	216
SSR31617	7/8	12	1-11/16	3-1/4	302	SPECIAL	3/4	AL	1-1/2	2-13/16	-
SPECIAL	7/8	AL	1-11/16	3-1/4	-	SSR31657	1	6	1-13/16	3-9/16	280
SSR31621	1	6	1-13/16	3-9/16	280	SSR31660	1	12	1-13/16	3-9/16	430
SSR31620	1	12	1-13/16	3-9/16	430	SPECIAL	1	AL	1-13/16	3-9/16	-

Eye Bolts/Ring Bolts/Eye Nuts

Stainless Steel Nut Eye Bolts

- Forged
- 304 Stainless Steel Plain and Shoulder Pattern

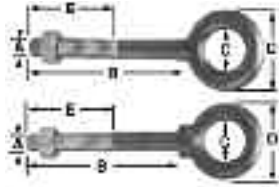

Stock No.	Thread Dia. A	Shank Length B	I.D. of Eye C	O.D. of Eye D	Thread Length E	Blanks*	Approx. Wt. Per 100 Pcs.	Rated Cap. † (lbs)
Plain Pattern								
SS12314	1/4	4	1/2	1	1	SSR12314	8	460
-	1/4	6	1/2	1	1	SSR12316	9	460
SS12323	5/16	4	5/8	1-1/4	1-1/4	SSR12323	15	780
SS12334	3/8	4	3/4	1-1/2	1-1/2	SSR12334	25	1,160
-	3/8	6	1	1-1/2	1-1/2	SSR12336	29	1,160
SS12341	1/2	4-1/2	1	1-5/16	2	SSR12341	41	2,150
SS12343	1/2	6	1	1-5/16	2	SSR12343	42	2,150
-	1/2	12	1	1-5/16	2	SSR12348	55	2,150
SPECIAL	1/2	AL	1	1-5/16	2	SPECIAL	-	2,150
SS12350	5/8	4	1-3/8	2-1/2	2-1/4	SSR12350	82	3,440
SS12352	5/8	6	1-3/8	2-1/2	2-1/4	SSR12352	98	3,440
-	5/8	12	1-3/8	2-1/2	2-1/4	SSR12357	125	3,440
SPECIAL	5/8	AL	1-3/8	2-1/2	2-1/4	SPECIAL	-	3,440
SS12362	3/4	6	1-1/2	2-13/16	2-1/2	SSR12362	138	5,140
-	3/4	12	1-1/2	2-13/16	2-1/2	SSR12367	175	5,140
SPECIAL	3/4	AL	1-1/2	2-13/16	2-1/2	SPECIAL	-	5,140
SS12371	7/8	6	1-11/16	3-1/4	2-1/2	SSR12371	214	7,130
-	7/8	12	1-11/16	3-1/4	2-1/2	SSR12375	300	7,130
SPECIAL	7/8	AL	1-11/16	3-1/4	2-1/2	SPECIAL	-	7,130
SS12380	1	6	1-13/16	3-9/16	3	SSR12380	280	9,370
-	1	12	1-13/16	3-9/16	3	SSR12385	350	9,370
SPECIAL	1	AL	1-13/16	3-9/16	3	SPECIAL	-	9,370
Shoulder Pattern								
SS17734	3/8	4-1/2	3/4	1-1/2	1-1/2	SSR17734	25	1,160
-	3/8	6	3/4	1-1/2	1-1/2	SSR17736	29	1,160
-	3/8	10	3/4	1-1/2	1-1/2	SSR17739	34	1,160
SPECIAL	3/8	AL	3/4	1-1/2	1-1/2	SPECIAL	-	1,160
SS17741	1/2	4	1	1-15/16	2	SSR17741	41	2,150
SS17743	1/2	6	1	1-15/16	2	SSR17743	42	2,150
-	1/2	12	1	1-15/16	2	SSR17745	55	2,150
SPECIAL	1/2	AL	1	1-15/16	2	SPECIAL	-	2,150
SS17750	5/8	4	1-3/8	2-1/2	2-1/4	SSR17750	82	3,440
SS17752	5/8	6	1-3/8	2-1/2	2-1/4	SSR17752	98	3,440
-	5/8	12	1-3/8	2-1/2	2-1/4	SSR17754	125	3,440
SPECIAL	5/8	AL	1-3/8	2-1/2	2-1/4	SPECIAL	-	3,440
SS17762	3/4	6	1-1/2	2-13/16	2-1/2	SSR17762	138	5,140
-	3/4	12	1-1/2	2-13/16	2-1/2	SSR17767	175	5,140
SPECIAL	3/4	AL	1-1/2	2-13/16	2-1/2	SPECIAL	-	5,140
SS17690	1	6	1-13/16	3-9/16	3	SSR17690	280	9,370
-	1	12	1-13/16	3-9/16	3	SSR17693	350	9,370
SPECIAL	1	AL	1-13/16	3-9/16	3	SPECIAL	-	9,370

† Rated capacity - Full sized shank and eye - unaltered.

* Blanks have no rated capacity.

** Note - 5/8" to 1" diameter shank lengths can be manufactured longer than 18" on request.

Shoulder Nut Ring Bolts

Crosby® G-257

- Forged Steel - Quenched and Tempered.
- Diameter of ring stock is same as shank diameter.
- Hot Dip galvanized.
- All Bolts Hot Dip galvanized after threading.

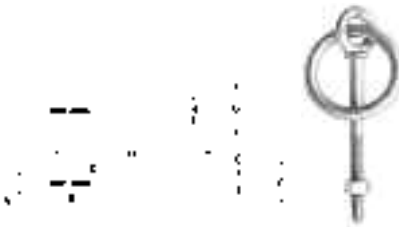

Ring Bolt Size (in)	G-257 Stock No. Galv.	* WLL (lbs)	Wt. Per 100 pcs. (lbs)	Dimensions (in)							
				A	B	C	D	E	F	G	H
3/8 x 4-1/2	1046335	1200	56.60	.38	2.50	4.50	7.66	.38	1.38	2.00	.66
1/2 x 6	1046371	2200	100.00	.50	3.00	6.00	10.00	.50	1.75	2.50	.91

* Ultimate load is 5 times the Working Load Limit.

Pad Eyes - Crosby®

- Forged Steel - Quenched and Tempered.
- Forged from 1035 Carbon Steel.
- Excellent welding qualities.
- Widely used on farm machinery, trucks, steel hulled marine vessels and material handling equipment.
- Reference American Welding Society specifications for proper welding procedures.



Size No.	S-264 Stock No. S.C.	Wt. per 100 pcs. (lbs)	Dimensions (in)							
			B	C	D	E	G	H	L	
0*	1090722	2.80	.25	.19	.63	.31	.63	.09	.75	
1*	1090740	6.50	.38	.25	.88	.41	.88	.13	1.03	
1-1/2*	1090768	10.40	.63	.25	1.00	.44	1.13	.16	1.31	
2	1090786	21.10	.75	.38	1.06	.50	1.50	.19	1.63	
4	1090802	52.20	1.00	.56	1.44	.78	2.13	.22	2.34	
5	1090820	82.50	1.25	.69	1.75	.81	2.63	.25	2.75	

Lifting Eyes - Crosby®

- Forged Steel - Quenched and Tempered.

* Ultimate Load is 5x the Working Load Limit. Rating based on UNC thread size shown in column "H".



Size No.	S-405 Stock No. S.C.	WLL* (lbs)	Wt. Each (lbs)	Dimensions (in)											
				A	C	D	E	F	H	J	L	S	T		
1	1090269	850	.10	1.25	.75	1.06	.59	1.00	.31	.69	.25	2.38			
2	1090287	1250	.20	1.63	1.00	1.25	.75	.56	.38	.81	.31	3.00			
3	1090303	2250	.50	2.00	1.25	1.50	1.00	.81	.50	1.13	1.25	3.75			
4	1090321	3600	.79	2.50	1.50	2.00	1.19	1.00	.63	1.31	1.50	4.69			
5	1090349	5200	1.25	3.00	1.75	2.38	1.38	1.13	.75	1.50	1.75	5.63			
6	1090367	7200	2.25	3.50	2.00	2.63	1.63	1.31	.88	1.88	1.88	6.31			
7	1090385	10000	3.25	4.00	2.25	3.06	1.88	1.56	1.00	2.13	2.06	7.06			
8	1090401	12500	4.70	4.50	2.50	3.50	1.94	1.88	1.13	2.38	2.50	8.25			
10	1090410	18000	9.33	5.62	3.12	4.00	2.38	2.38	1.53	3.00	2.94	9.69			

Eye Nuts (Forged)

Crosby® G-400

- Forged Steel - Quenched and Tempered.
- Hot Dip galvanized.
- Tapped with standard UNC class 2 threads after galvanizing.



Size No.	Stock Size (in) S	G-400 Stock No. Galv.	Std. Tap Size	WLL* (lbs)	Wt. Ea. (lbs)	Dimensions (in)										
						A	C	D	E	F	J	M	T			
1	.25	1090438	1/4	520	.09	1.25	.75	1.06	.66	.50	.69	.25	1.69			
2	.31	1090474	3/8	1250	.17	1.63	1.00	1.25	.75	.56	.81	.38	2.06			
3A	.38	1090517	1/2	2250	.28	2.00	1.25	1.50	1.00	.81	1.00	.50	2.50			
4	.50	1090535	5/8	3600	.60	2.50	1.50	2.00	1.19	1.00	1.31	.63	3.19			
5	.63	1090553	3/4	5200	1.00	3.00	1.75	2.38	1.38	1.13	1.50	.75	3.88			
6	.75	1090571	7/8	7200	1.65	3.50	2.00	2.63	1.63	1.31	1.88	.88	4.31			
7	.88	1090599	1	10000	2.69	4.00	2.25	3.06	1.88	1.56	2.13	1.00	5.00			
8	1.00	1090633	1-1/4	15500	3.87	4.50	2.50	3.50	1.94	1.88	2.38	1.25	5.75			
9	1.13	1090651	1-3/8	18500	5.00	5.00	2.75	3.75	2.00	2.00	2.56	1.38	6.25			
10	1.25	1090679	1-1/2	22500	6.78	5.63	3.13	4.00	2.38	2.25	3.00	1.50	6.75			
11	1.50	1090697	2	40000	14.60	7.00	4.00	6.25	4.00	3.38	4.00	2.00	10.00			

Ultimate Load is 5X the Working Load Limit. Rating based on standard tap size.

Stainless Steel Eye Nuts

Stock No.	Thread Dia. T	Diameter (in)						Wt. per 100 Pcs	Rated Cap.
		A	B	C	D	E	F		
304 Stainless Steel • Forged									
SS16037	3/8-16	7/8	5/8	1-1/4	2	2-1/2	3/8	22.0	2,700
SS16050	1/2-13	7/8	5/8	1-1/4	2	2-1/2	3/8	19.5	2,700
SS16062	5/8-11	1-3/8	3/4	1-1/2	2-1/2	3	1/2	60.0	5,000
SS16075	3/4-10	1-3/8	3/4	1-1/2	2-1/2	3	1/2	56.0	5,000
SS16087	7/8-9	1-9/16	1-1/16	2-1/4	4	5	7/8	174.1	10,000
SS16100	1-8	1-9/16	1-1/16	2-1/4	4	5	7/8	167.2	10,000
316 Stainless Steel • Forged									
SS16237	3/8	7/8	5/8	1-1/4	2	2-1/2	3/8	22.0	2,700
SS16250	1/2	7/8	5/8	1-1/4	2	2-1/2	3/8	19.5	2,700
SS16262	5/8	1-3/8	3/4	1-1/2	2-1/2	3	1/2	60.0	5,000
SS16275	3/4	1-3/8	3/4	1-1/2	2-1/2	3	1/2	56.0	5,000

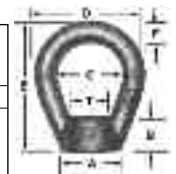

Rigging Fittings

Nuts/Pins/Rod Ends

Sleeve Nuts

Part No.	Thread Dia. (in) D	Dimensions (in)			Wt. Each (lbs)
		W	C	L	
40020	3/4	1-1/4	1-7/16	5	1.12
40021	7/8	1-7/16	1-5/8	7	1.75
40022	1	1-5/8	1-13/16	7	2.46
40023	1-1/4	2	2-1/4	7-1/2	4.04
40024	1-1/2	2-3/8	2-11/16	8	6.16
40025	2	3-1/8	3-1/2	9	12.24
40026	2-1/2	3-7/8	4-3/8	10	21.12
40027	3	4-5/8	5-1/4	11	33.22
40028	3-1/2	5-3/8	6	12	49.07
40029	4	6-1/8	6-7/8	13	69.22
40030	4-1/2	6-7/8	7-15/16	14	90.00
40031	5	7-5/8	8-7/8	15	110.00
40032	6	9-1/8	10-5/8	17	176.00

- Material: Carbon Steel
- Threads: U.N.C. Class 2B.
- Right or Left Hand
- Finish: Self-Colored
- Options: Plating

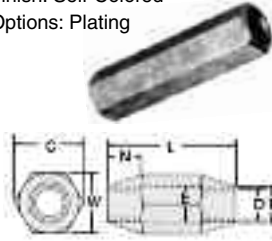

Tapered Sleeve Nuts

Part No.	Thread Dia. (in) D	Diameter (in)							Wt. Each (lbs)
		W	C	L	N	E	T		
40020T	3/4	1-1/4	1-7/16	5	-	-	-	1.12	
40021T	7/8	1-7/16	1-5/8	7	1-7/16	1	1-1/4	1.75	
40022T	1	1-5/8	1-13/16	7	1-7/16	1-1/8	1-3/8	2.46	
40023T	1-1/4	2	2-1/4	7-1/2	1-5/8	1-3/8	1-5/8	4.04	
40024T	1-1/2	2-3/8	2-11/16	8	1-7/8	1-5/8	1-7/8	6.16	
40025T	2	3-1/8	3-1/2	9	2-5/16	2-1/8	2-5/8	12.24	
40026T	2-1/2	3-7/8	4-3/8	10	2-3/4	2-5/8	3-1/8	21.12	
40027T	3	4-5/8	5-1/4	11	3-3/16	3-1/8	3-3/4	33.22	
40028T	3-1/2	5-3/8	6	12	3-5/8	3-5/8	4-3/8	49.07	
40029T	4	6-1/8	6-7/8	13	4-1/16	4-1/8	5-1/8	69.22	
40030T	4-1/2	6-7/8	7-15/16	14	5	4-3/4	5-7/8	90.00	
40031T	5	7-5/8	8-7/8	15	5-1/2	5-1/4	6-1/2	110.00	
40032T	6	9-1/8	10-5/8	17	6-1/2	6-1/4	7-3/4	176.00	

Coupling Nuts

- Material: Carbon Steel
- Threads: U.N.C. Class 2B.
- Right Hand
- Finish: Self-Colored, Plated

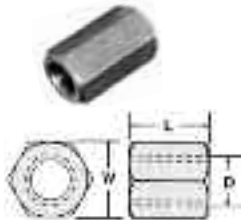

Part No.	Thread Dia. (in) D	Length L	W	Wt. Per 100 (lbs)
40000	3/8	x 1-1/8	5/8	11
40001	1/2	x 1-1/2	13/16	19
40002	5/8	x 2	15/16	31
40003	3/4	x 2-1/4	1-1/8	47
40004	7/8	x 2-3/4	1-3/8	87
40005	1	x 3	1-5/8	137
40006	1-1/8	x 3-1/2	1-3/4	175
40007	1-1/4	x 3-3/4	1-7/8	208
40008	1-3/8	x 4-1/8	2	240
40009	1-1/2	x 4-1/2	2-1/4	357
40010	1-3/4	x 5-1/4	2-3/4	614
40011	2	x 6	3	795
40012	2-1/2	x 7-1/2	3-1/2	1,583
40013	3	x 8	4-1/2	3,600
40014	3-1/4	x 9	5	3,726
40015	3-1/2	x 10-1/4	5-3/8	4,859
40016	3-3/4	x 11	5-3/4	5,918
40017	4	x 11-1/2	6-1/8	6,992

Recessed Nuts & Pins

- Material: To Customer Spec
- Threads: 6 U.N.C. Class 2A/2B
- Finish: Self-Colored

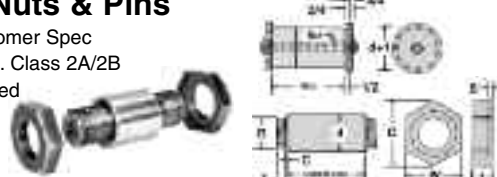

Dia. of Pin d (in)	Pin		Nut (Suggested Dimensions - in)										Wt. Each (lbs)
	Thread		Recess		Nut						Rough Hole		
	Dia. D (in)	Length T (in)	Rough Dia.	Depth	c	t	W	C	W	C	Rough Dia.	Depth	
3	2	2-1/4	1-1/2	1	1/8	7/8	3	3-3/8	2-5/8	1/4	1-1/4	1	1
	2-1/2	2-3/4	2	1-1/8	1/8	1	3-5/8	4-1/8	3-1/8	1/4	1-3/4	2	2
	3-1/4	3-1/2	2-1/2	1-1/4	1/8	1-1/8	4-3/8	5	3-7/8	3/8	2-1/4	3	3
4-1/4	3-3/4	4	3	1-3/8	1/4	1-1/4	4-7/8	5-5/8	4-3/8	3/8	2-3/4	4	4
	4-1/2	4-3/4	3-1/2	1-1/2	1/4	1-3/8	5-3/4	6-5/8	5-1/4	1/2	3-1/4	5	5
	5	5-1/4	4	1-5/8	1/4	1-1/2	6-1/4	7-1/4	5-3/4	1/2	3-3/4	6	6
5-1/2	5-3/4	6	4-1/2	1-3/4	1/4	1-5/8	7	8-1/8	6-1/2	5/8	4-1/4	8	8
	6-1/4	6-1/2	5	1-7/8	3/8	1-3/4	7-5/8	8-7/8	7	5/8	4-3/4	10	10
	6-3/4	7	5-1/2	2	3/8	1-7/8	8-1/8	9-3/8	7-1/2	3/4	5-1/4	12	12
7-3/4	7-1/4	7-1/2	5-1/2	2	3/8	1-7/8	8-5/8	10	8	3/4	5-1/4	14	14
	8	8-1/4	6	2-1/4	3/8	2-1/8	9-3/8	10-7/8	8-3/4	3/4	5-3/4	19	19
	8-1/2	8-3/4	9	2-1/4	3/8	2-1/8	10-1/4	11-7/8	9-5/8	3/4	5-3/4	24	24
9-1/4	9-1/2	6	2-3/8	3/8	2-1/4	11-1/4	13	10-5/8	3/4	5-3/4	32	32	
	9-3/4	0	6	2-3/8	3/8	2-1/4	11-1/4	13	10-5/8	3/4	5-3/4	32	32

Hitch Pins

Product code	UPC 43927-	Dim. (in)		Std. pack	Approx. Wt. per Pk. (lbs)
		Dia.	Usable length		
M1195	42879	1/2	3-1/2	20	8
M1200	42885	5/8	3-3/4	20	12
M1205	42894	3/4	4	10	9
M1210	42901	7/8	4-1/4	10	12
M1215	42909	1	4-3/4	10	16
M1218	42915	5/8	6	10	8
M1220	42922	3/4	6-1/4	10	12
M1225	42930	7/8	6-1/2	5	8.5
M1230	42938	1	6-3/4	5	11
M1240	42946	1-1/8	7	5	14
M1250	42955	1-1/4	7	5	18

CM - Forged/Wire Handle

- Heat treated for strength properties.
- Forged of high strength steel.
- Complete with grip clip.

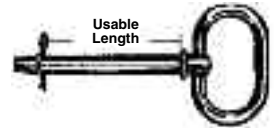

Product code	UPC 43927-	Dim. (in)		Std. pack	Approx. Wt. per Pk. (lbs)
		Dia.	Usable length		
M1206	42965	3/4	4	10	9
M1211	42968	7/8	4-1/4	10	12
M1216	42971	1	4-3/4	10	16
M1219	42963	5/8	6	10	8
M1221	42974	3/4	6-1/4	10	12
M1226	42977	7/8	6-1/2	5	8.5
M1231	42981	1	6-3/4	5	11
M1241	42985	1-1/8	7	5	14
M1251	42989	1-1/4	7	5	18
M1261*	42994	1-3/8	7	5	23
M1271*	43001	1-1/2	8	5	33

CM - Forged/Solid Handle

- Heat treated for strength properties.
- Forged of high strength steel.
- Complete with grip clip.

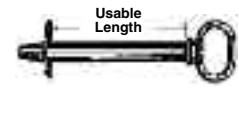

*These pins are furnished with linch pins.

CM T Handle Clevis Pin

- May be used for clevis replacement.
- Pins are zinc plated and have hairpin lock.
- Heat treated.



Prod. Code	For Clevis Straight	For Clevis Twist	Usable Length (in)	Std. Pack	Wt. Per Pack (lbs)
M811	M8158	M8258	1/2 x 2-1/4	20	7
M813	M8134	M8234	5/8 x 3-1/8	20	11
M817	M8878	M8078	3/4 x 3-1/4	10	7
M817	M8178	M8278	3/4 x 3-1/4	10	7
M819	M8190	M8290	7/8 x 3-3/4	10	12
M829	M8195	M8295	1 x 4-1/4	10	15

ROD ENDS

Stainless Steel Rod Ends

304 Stock No.	316 Stock No.	Shank Dia. (in) A	Center of Eye to End B	Head Dia. (in) C	Head Thickness (in) D	Approx. Wt. Per 100 pcs. (lbs)
SSR18050	SSR31670	3/8	6	11/16	7/16	25
SPECIAL	SPECIAL	3/8	Up to 12"	11/16	7/16	-
SSR18065	SSR31675	1/2	6	15/16	9/16	50
SSR18070	SSR31677	1/2	12	15/16	9/16	75
SPECIAL	SPECIAL	1/2	Up to 24"	15/16	9/16	-
SSR 18105	SSR31680	5/8	6	1-3/16	11/16	89
SSR18110	SSR31682	5/8	12	1-3/16	11/16	153
SSR18114	SPECIAL	5/8	18	1-3/16	11/16	200
SPECIAL	SPECIAL	5/8	Up to 26"	1-3/16	11/16	-
SSR18130	SSR31685	3/4	6	1-7/16	13/16	125
SSR18135	SSR31687	3/4	12	1-7/16	13/16	216
SSR18137	SSR31689	3/4	18	1-7/16	13/16	304
SPECIAL	SPECIAL	3/4	Up to 27"	1-7/16	13/16	-
SSR18150	SSR31690	7/8	6	1-11/16	15/16	190
SSR18155	SSR31692	7/8	12	1-11/16	15/16	302
SPECIAL	SPECIAL	7/8	Up to 30"	1-11/16	15/16	-
SSR18160	-	7/8	18	1-11/16	15/16	398
SSR18170	SSR31695	1	6	2	1	250
SSR18175	SSR31697	1	12	2	1	430
SSR18177	-	1	18	2	1	550
SPECIAL	SPECIAL	1	Up to 30"	2	1	-

- Forged
- 304 and 316 Stainless Steel

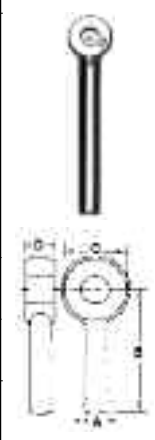

Rod Ends/Stainless Steel Fittings

Rod Ends (Carbon Steel)

- Forged • Carbon Steel • Self-Colored

May be supplied either blank or machined, BUT ARE STOCKED AS BLANK FORGINGS ONLY. Forging lengths (B) are standard, but other lengths can be made up special in quantity lots.

Rod Ends can be furnished to any length desired. In certain sizes and wherever practical we forge the longer lengths solid, thus maximum strength is assured. Threading and cross drilling can be modified to meet customer requirements.

We are always interested in inquiries for Rod Ends of special sizes. Refer to the chart for the special sizes available, many of which are carried in stock, blank, and can be machined to specification.

- Shank lengths can vary +1/2" -0"
- Standard forging tolerances.
- Supplied in fine thread and metric threads.
- Available in 1008, 1030, 4140, 8620 steel and stainless steel. Self-colored will always be furnished unless otherwise specified. INFORMATION REQUIRED: (A) Shank diameter (B) Length center of eye to end (C) Head/Boss diameter (D) Head thickness (E) Size of drilled eye hole (F) Thread length with or without nuts.

Stock No.	Shank Dia. (in) A	Center of Eye to End B	Head Dia. (in) C	Head Thkns. (in) D	Approx. Wt. Per 100 pcs. (lbs)
Forged Rod Ends (1030)					
R-18004	1/4	1-3/4	15/32	5/16	3.5
R-18006	1/4	2-1/2	1/2	9/32	4.5
R-18010	1/4	2	1/2	9/32	4.5
R-18012	1/4	AL	1/2	9/32	4.5
R-18020	5/16	4	3/4	5/16	13.0
R-18022	5/16	1-3/4	5/8	11/32	14.0
R-18024	5/16	2	13/16	7/16	15.0
R-18034	3/8	2	11/16	7/16	5.0
R-18036	3/8	4-1/2	11/16	7/16	6.0
R-18038	3/8	2-1/2	13/16	7/16	5.0
R-18045	3/8	3-11/16	1	7/16	5.0
R-18048*	3/8	6	11/16	7/16	24.0
SPECIAL*	3/8	Up to 12"	11/16	7/16	-
R-18050*	3/8	AL	11/16	7/16	6.0
R-18052*	7/16	4-3/8	13/16	1/2	45.0
SPECIAL*	-	Any Length	-	7/16	-
R-18054*	1/2	3	15/16	9/16	40.0
R-18055*	1/2	7	15/16	9/16	45.0
R-18056*	1/2	2-3/4	1-1/16	9/16	40.0
R-18065*	1/2	6	15/16	9/16	45.0
R-18070*	1/2	12	15/16	9/16	90.0
R-18072*	1/2	3-3/4	1-1/8	1/2	40.0
R-18075*	1/2	6	1-1/8	1/2	36.0
SPECIAL*	1/2	Up to 24"	15/16	9/16	-
SPECIAL*	1/2	Up to 24"	1-1/8	1/2	-
R-18100*	9/16	1-5/8	7/8	9/16	65.0
R-18102*	5/8	3-1/4	1-3/16	11/16	65.0
R-18103*	5/8	4-1/4	1-3/16	11/16	68.0
R-18104*	5/8	5-1/2	1-3/16	11/16	70.0
R-18105*	5/8	6	1-3/16	11/16	73.0
R-18110*	5/8	12	1-3/16	11/16	130.0
SPECIAL*	5/8	Up to 26"	1-3/16	11/16	-
R-18122*	3/4	2	1-1/2	7/8	95.0
R-18124*	3/4	3-1/2	1-7/16	13/16	100.0
R-18125*	3/4	4-3/4	1-7/16	13/16	105.0
R-18130*	3/4	6	1-7/16	13/16	110.0
R-18135*	3/4	12	1-7/16	13/16	200.0
SPECIAL*	3/4	Up to 27"	1-7/16	13/16	-
R-18150*	7/8	6	1-11/16	15/16	159.0
R-18155*	7/8	12	1-11/16	15/16	265.0
SPECIAL*	7/8	Up to 30"	1-11/16	15/16	-
R-18170*	1	6	2	1	213.0
R-18175*	1	12	2	1	350.0
SPECIAL*	1	Up to 30"	2	1	-
R-18194*	1-1/4	12	2-1/2	1-1/4	575.0
SPECIAL*	1-1/4	Up to 24"	2-1/2	1-1/4	-
SPECIAL*	1-1/2	Up to 24"	3	1-1/2	-
SPECIAL*	1-3/4	Up to 24"	3-1/2	1-3/4	-
SPECIAL*	2	Up to 24"	4	2	-
Cold Headed Rod Ends (1008-1010)					
R-18016 †	-	.213	2.875	.535	.281
R-18017 †	-	.250	4.250	.500	.281
R-18021 †	-	.272	4.000	.750	.313
R-18031 †	-	.328	1.500	.745	.438
R-18061 †	-	.444	1.750	.938	.563
R-18066 †	-	.444	6.000	.938	.563
R-18076 †	-	.444	4.813	1.125	.500
R-18086 †	-	.444	3.000	.938	.563



† Supplied with rolled thread diameter.
AL = Any length shank
* Also available in alloy, stainless steel and other materials.

STAINLESS STEEL FITTINGS:

Heavy Wire Rope Clip

304 Stainless Steel Precision Cast

Item	Dimensions (in)					Wt. (lbs)
	A	B	C	D	E	
S0122-FS02	1/16	0.09	0.43	0.56	0.50	0.02
S0122-FS03	1/8	0.12	0.50	0.62	0.62	0.03
S0122-FS04	5/32	0.15	0.56	0.75	0.75	0.04
S0122-FS05	3/16	0.18	0.62	0.81	0.87	0.06
S0122-FS07	1/4	0.25	0.75	0.87	1.12	0.10
S0122-FS08	5/16	0.31	1.00	1.12	1.37	0.18
S0122-FS10	3/8	0.37	1.00	1.37	1.75	0.35
S0122-FS13	1/2	0.50	1.37	1.50	2.00	0.52
S0122-FS14	9/16	0.56	1.87	1.50	2.00	0.85
S0122-FS16	5/8	0.56	2.00	1.87	2.31	0.89
S0122-FS20	3/4	0.56	2.00	2.12	2.50	1.05
S0122-FS22	7/8	0.62	2.37	2.37	2.75	1.60
S0122-FS25	1	0.68	2.37	2.50	3.00	1.90

Fed. Specification: FF-C-450D, Type 1.



Heavy Wire Rope Clip

316 Stainless Steel Forged

Item	Dimensions (in)					Wt. (lbs)
	A	B	C	D	E	
S0122-0003	1/8	0.15	0.56	0.75	0.75	0.04
S0122-0005	3/16	0.25	0.75	0.87	1.12	0.10
S0122-0007	1/4	0.31	1.00	1.12	1.37	0.18
S0122-0008	5/16	0.37	1.00	1.37	1.75	0.35
S0122-0010	3/8	0.50	1.37	1.50	2.00	0.52
S0122-0013	1/2	0.56	2.00	1.87	2.31	0.89
S0122-0016	5/8	0.56	2.00	2.12	2.50	1.05
S0122-0020	3/4	0.62	2.37	2.37	2.75	1.60

Note: Measurements comply with Federal specification: FF-C-450D, Type 1. These are heavy duty clips and are one size larger than the above clips. Please call as other sizes are available on special order.



Thimble

304 Stainless Steel Stamped

Item	Size	Dimensions (in)				Wt. (lbs)
		A	B	C	D	
S0123-0002	5/64	0.09	0.31	0.62	0.03	0.01
S0123-0003	1/8	0.12	0.34	0.75	0.04	0.01
S0123-0004	5/32	0.15	0.50	0.87	0.04	0.01
S0123-0005	3/16	0.21	0.50	0.87	0.04	0.02
S0123-0007	1/4	0.25	0.68	1.06	0.05	0.03
S0123-0008	5/16	0.37	0.87	1.37	0.06	0.04
S0123-0010	3/8	0.43	1.00	1.62	0.06	0.06
S0123-0013	1/2	0.56	1.25	1.87	0.07	0.09
S0123-0014	9/16	0.62	1.37	2.25	0.07	0.12
S0123-0016	5/8	0.68	1.43	2.37	0.08	0.18
S0123-0018	3/4	0.81	1.50	2.75	0.08	0.28
S0123-0022	7/8	0.93	1.75	3.00	0.10	0.38
S0123-0025	1	1.06	2.00	3.12	0.10	0.46

Commercial Grade.



Fed. Spec. Thimble

316 Stainless Steel Stamped

Item	Size (in)	Dimensions (in)				Wt. (lbs)
		A	B	C	D	
S0123-FS05	3/16	0.21	0.75	1.37	0.06	0.04
S0123-FS07	1/4	0.28	0.87	1.62	0.07	0.08
S0123-FS08	5/16	0.34	1.06	1.87	0.08	0.14
S0123-FS10	3/8	0.43	1.12	2.00	0.11	0.25
S0123-FS13	1/2	0.56	1.50	2.50	0.15	0.53
S0123-FS16	5/8	0.68	1.75	3.00	0.18	0.70
S0123-FS20	3/4	0.81	2.00	3.75	0.22	1.25
S0123-FS22	7/8	0.93	2.25	4.00	0.22	1.50
S0123-FS25	1	1.12	2.50	4.37	0.25	2.50
S0123-FS28	1-1/8	1.14	3.00	5.31	0.23	1.74
S0123-FS32	1-1/4	1.27	3.46	6.29	0.23	2.20

Note: Dimensions and working load are to Federal specification: FF-T-276b, Type III.



Rigging Fittings

Stainless Steel Fittings

Heavy Thimble

316 Stainless Steel Stamped

Item	Size (in)	Dimensions (in)				Wt. (lbs)
		A	B	C	D	
S0124-FS03	1/8	0.12	0.36	0.66	0.03	0.01
S0124-FS05	3/16	0.18	0.43	0.78	0.04	0.02
S0124-FS07	1/4	0.25	0.59	1.06	0.06	0.03
S0124-FS08	5/16	0.32	0.75	1.29	0.06	0.05
S0124-FS10	3/8	0.40	1.00	1.61	0.08	0.06
S0124-FS13	1/2	0.56	1.14	2.08	0.10	0.12
S0124-FS16	5/8	0.63	1.25	2.24	0.12	0.24
S0124-FS20	3/4	0.76	1.77	3.30	0.15	0.47

Note: Please call as some sizes are not available from stock.



Extra Heavy Duty Thimble

304 Stainless Steel Precision Cast

Item	Size (in)	Dimensions (in)				Wt. (lbs)
		A	B	C	D	
S0123-XH06	1/4	0.28	0.62	1.06	0.14	0.08
S0123-XH08	5/16	0.31	0.93	1.68	0.18	0.12
S0123-XH10	3/8	0.43	1.12	2.00	0.22	0.24
S0123-XH13	1/2	0.50	1.37	2.50	0.25	0.40
S0123-XH16	5/8	0.62	1.75	3.25	0.32	0.71
S0123-XH20	3/4	0.75	2.00	3.50	0.36	1.10
S0123-XH22	7/8	0.87	2.37	3.87	0.40	1.50
S0123-XH25	1	1.00	2.75	4.50	0.40	2.00

Note: Precision cast extra heavy duty thimble, not formed from flat steel. Exceptional resistance to wear and crushing.



Round Ring

316 Stainless Steel Welded

Item	Dim. (in)		WLL (lbs)
	A	B	
S0139-0320	1/8	3/4	140
S0139-0325	1/8	1	125
S0139-0425	5/32	1	300
S0139-0430	5/32	1-1/4	280
S0139-0440	5/32	1-1/2	250
S0139-0525	3/16	1	350
S0139-0530	3/16	1-1/4	330
S0139-0540	3/16	1-1/2	275
S0139-0550	3/16	2	250
S0139-0625	1/4	1	600
S0139-0630	1/4	1-1/4	500

Item	Dim. (in)		WLL (lbs)
	A	B	
S0139-0640	1/4	1-1/2	400
S0139-0650	1/4	2	300
S0139-0840	5/16	1-1/2	720
S0139-0845	5/16	1-3/4	700
S0139-0850	5/16	2	600
S0139-0865	5/16	2-1/2	500
S0139-1065	3/8	2-1/2	1000
S0139-1080	3/8	3-1/4	800
S0139-1210	1/2	4	1600
S0139-1260	1/2	2-3/8	1400
S0139-1280	1/2	3-1/4	1200

Note: Other sizes available on special order.

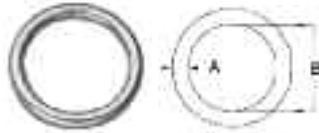

Master Link

316 Stainless Steel Formed & Welded

Item	Dimensions (in)			WLL (lbs)	Wt. (lbs)
	A	B	C		
S0650-0013	1/2	4.75	2.50	2000	0.85
S0650-0016	5/8	5.75	3.00	3000	1.50
S0650-0020	3/4	6.50	3.50	4000	2.65
S0650-0025	1	7.00	3.50	8000	4.90
S0650-0032	1-1/4	9.00	4.25	12000	9.35

Note: Each link is stamped with size and working load, and has been proof tested and passivated. Make sure all components in your assembly are matched. Made in Germany.



Hammerlock Link

316 Stainless Steel Forged

Item	Dimensions (in)				WLL (lbs)	Wt. (lbs)
	A	B	C	D		
S0655-0005	3/16	1.42	0.50	0.50	1100	0.11
S0655-0007	1/4	2.09	0.64	0.64	2200	0.26
S0655-0008	5/16	2.20	0.75	0.75	2800	0.40
S0655-0010	3/8	2.81	0.91	0.91	4400	0.73
S0655-0013	1/2	3.62	1.09	1.09	7400	1.54
S0655-0016	5/8	4.09	1.45	1.45	11000	2.68

Note: Working load is based on gradual pull and not a shock load. Always make sure all components are matched with the same working loads.

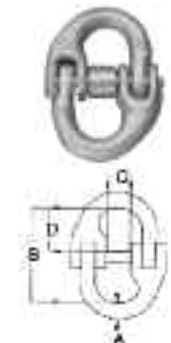

Connecting Link

316 Stainless Steel Precision Cast

Item	Size (in)	Dimensions (in)			WLL (lbs)	Wt. (lbs)
		A	B	C		
S0460-0005	3/16	0.20	0.35	0.70	400	0.03
S0460-0006	1/4	0.24	0.43	0.84	1000	0.04
S0460-0008	5/16	0.32	0.48	0.95	1600	0.09
S0460-0010	3/8	0.40	0.60	1.15	2400	0.14
S0460-0013	1/2	0.50	0.75	1.45	3800	0.28
S0460-0016	5/8	0.60	0.95	1.90	5500	0.57

Note: Do not use without riveting pins securely.



Chain Shackle

316 Stainless Steel with Oversize Screw Pin

Item	Dimensions (in)				WLL (lbs)	Wt. (lbs)
	A	B	C	D		
S0115-FS07	1/4	5/16	0.50	0.87	1000	0.09
S0115-FS08	5/16	3/8	0.50	1.00	1500	0.17
S0115-FS10	3/8	7/16	0.63	1.25	2000	0.30
S0115-FS12	7/16	1/2	0.72	1.62	3000	0.44
S0115-FS13	1/2	5/8	0.81	1.75	4000	0.70
S0115-FS16	5/8	3/4	1.06	2.00	6000	1.25
S0115-FS20	3/4	7/8	1.25	2.37	8000	2.10
S0115-FS22	7/8	1	1.50	2.87	10000	3.20
S0115-FS25	1	1-1/8	1.63	3.25	12000	4.80

Meets dimensions of federal specification RR-C-271D, Type IV B, Class 2. Other sizes available on special order.

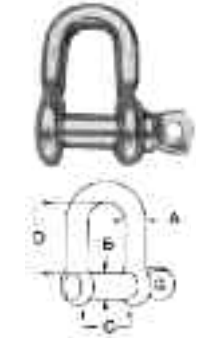

Bolt Chain Shackle

316 Stainless Steel with Oversize Bolt

Item	Dimensions (in)				WLL (lbs)	Wt. (lbs)
	A	B	C	D		
S0115-SA07	1/4	5/16	0.50	0.87	1000	0.11
S0115-SA08	5/16	3/8	0.50	1.00	1500	0.18
S0115-SA10	3/8	7/16	0.63	1.25	2000	0.30
S0115-SA12	7/16	1/2	0.72	1.62	3000	0.47
S0115-SA13	1/2	5/8	0.81	1.75	4000	0.67
S0115-SA16	5/8	3/4	1.06	2.00	6000	1.25
S0115-SA20	3/4	7/8	1.25	2.37	8000	2.10
S0115-SA22	7/8	1	1.50	2.87	10000	3.30
S0115-SA25	1	1-1/8	1.63	3.25	12000	4.80

Meets Dimensions of federal specification RR-C-271D, Type IV B, Class 3. Other sizes available upon special order.

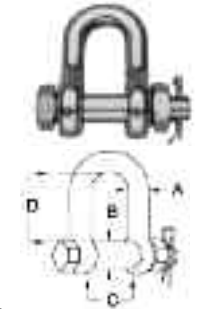

Round Pin Chain Shackle

316 Stainless Steel with Oversize Round Pin

Item	Dimensions (in)				WLL (lbs)	Wt. (lbs)
	A	B	C	D		
S0115-RP07	1/4	5/16	0.50	0.87	1000	0.11
S0115-RP08	5/16	3/8	0.50	1.00	1500	0.18
S0115-RP10	3/8	7/16	0.63	1.25	2000	0.30
S0115-RP12	7/16	1/2	0.72	1.62	3000	0.47
S0115-RP13	1/2	5/8	0.81	1.75	4000	0.67
S0115-RP16	5/8	3/4	1.06	2.00	6000	1.25
S0115-RP20	3/4	7/8	1.25	2.37	8000	2.10
S0115-RP22	7/8	1	1.50	2.87	10000	3.30
S0115-RP25	1	1-1/8	1.63	3.25	12000	4.80

Meets Dimensions of federal specification RR-C-271D, Type IV B, Class 1. Other sizes available on special order.

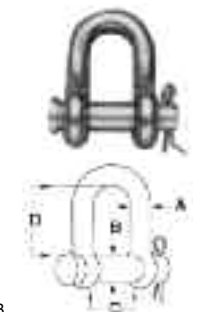

Long (D) Shackle

316 Stainless Steel with Screw Pin

Item	Dimensions (in)				WLL (lbs)	Wt. (lbs)
	A	B	C	D		
S0138-0004	5/32	0.15	0.31	1.20	360	0.03
S0138-0005	3/16	0.19	0.43	1.51	530	0.05
S0138-0006	1/4	0.25	0.50	1.75	750	0.08
S0138-0008	5/16	0.31	0.63	2.37	1320	0.18
S0138-0010	3/8	0.38	0.75	3.00	1700	0.36
S0138-0012	1/2	0.47	0.91	3.57	2500	0.56

Available in Titanium.

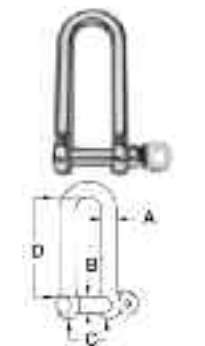

Stainless Steel Fittings

Wide (D) Shackle

316 Stainless Steel with Screw Pin

Item	Dimensions (in)			D	WLL (lbs)	Wt. (lbs)
	A	B	C			
S0114-0006	1/4	0.23	0.97	1.31	750	0.08
S0114-0008	5/16	0.32	1.12	1.24	1320	0.14
S0114-0010	3/8	0.39	1.60	2.18	1700	0.34
S0114-0012	1/2	0.47	1.90	2.61	2500	0.58

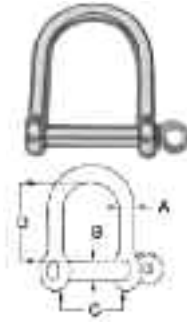

Straight (D) Shackle

316 Stainless Steel with Screw Pin

Item	Dimensions (in)			D	WLL (lbs)	Wt. (lbs)
	A	B	C			
S0115-0004	5/32	0.14	0.32	0.55	360	0.02
S0115-0005	3/16	0.19	0.42	0.76	530	0.04
S0115-0006	1/4	0.23	0.48	0.85	750	0.06
S0115-0008	5/16	0.30	0.69	1.12	1320	0.12
S0115-0010	3/8	0.38	0.80	1.38	1700	0.25
S0115-0012	15/32	0.46	0.98	1.66	2500	0.44
S0115-0013	1/2	0.54	1.10	1.85	2900	0.56
S0115-0016	5/8	0.62	1.26	2.00	4600	1.00
S0115-0020	3/4	0.74	1.45	2.56	6700	1.67
S0115-0022	7/8	0.86	1.74	3.05	8000	2.53
S0115-0025	1	0.96	1.97	3.47	10000	3.80
S0115-0032	1-1/4	1.25	1.56	5.70	12000	7.60

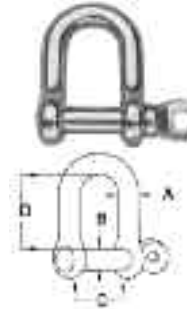

Available in Titanium.

Bow Shackle

316 Stainless Steel with Screw Pin

Item	Dimensions (in)			D	WLL (lbs)	Wt. (lbs)
	A	B	C			
S0116-0004	5/32	0.15	0.30	0.77	360	0.02
S0116-0005	3/16	0.19	0.44	0.94	530	0.04
S0116-0006	1/4	0.23	0.50	1.08	750	0.06
S0116-0008	5/16	0.30	0.67	1.47	1320	0.12
S0116-0010	3/8	0.38	0.81	1.78	1700	0.25
S0116-0012	15/32	0.47	0.98	2.18	2500	0.44
S0116-0013	1/2	0.55	1.10	2.31	2900	0.56
S0116-0016	5/8	0.62	1.26	3.01	4600	1.00
S0116-0020	3/4	0.75	1.48	3.35	6700	1.67
S0116-0022	7/8	0.85	1.72	3.87	8000	2.53
S0116-0025	1	0.96	1.92	4.43	10000	3.80
S0116-0032	1-1/4	1.25	2.56	5.70	12000	9.20

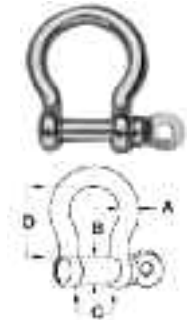

Special Bow Shackle

316 Stainless Steel with "No Snag" Pin

Item	Dimensions (in)			D	WLL (lbs)	Wt. (lbs)
	A	B	C			
S0116-NS06	1/4	0.23	0.49	1.08	750	0.07
S0116-NS08	5/16	0.30	0.67	1.47	1320	0.16
S0116-NS10	3/8	0.38	0.81	1.78	1700	0.30
S0116-NS12	15/32	0.47	0.98	2.18	2500	0.51
S0116-NS13	1/2	0.55	1.10	2.31	2900	0.65
S0116-NS16	5/8	0.62	1.26	3.01	4600	1.20
S0116-NS20	3/4	0.75	1.48	3.35	6700	2.00
S0116-NS22	7/8	0.85	1.72	3.87	8000	2.90
S0116-NS25	1	0.96	1.92	4.43	10000	3.80

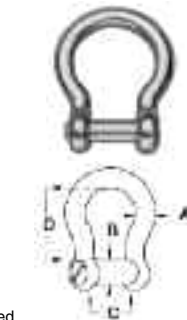

Note: No snag pin sits flush with body of shackle. It's recommended that the use of a locking fluid is used with this type of shackle.

Long (D) Shackle

316 Stainless Steel with Captive Pin

Item	Dimensions (in)			D	WLL (lbs)	Wt. (lbs)
	A	B	C			
S0138-CP04	5/32	0.17	0.32	1.18	360	0.03
S0138-CP05	3/16	0.17	0.38	1.49	530	0.05
S0138-CP06	1/4	0.21	0.45	1.78	750	0.08
S0138-CP08	5/16	0.27	0.62	2.39	1320	0.18
S0138-CP10	3/8	0.35	0.80	2.98	1700	0.36
S0138-CP12	1/2	0.42	0.91	3.56	2500	0.56

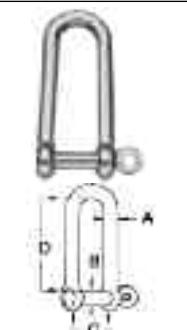

Note: Screw pin is captive and is not removable. When fully opened the end of the pin will sit flush with the inside of the shackle.

Turnbuckle Jaw and Jaw

316 Stainless Steel Forged



Item	Dimensions (in)					WLL (lbs)
	A	B	C	D	E	
S0108-JJ07	1/4	4.00	7.50	0.20	0.45	500
S0108-JJ08	5/16	4.50	8.50	0.25	0.51	800
S0108-JJ10	3/8	6.00	10.75	0.30	0.54	1200
S0108-JJ13	1/2	6.00	12.00	0.37	0.63	2200
S0108-JJ16	5/8	6.00	13.50	0.50	0.82	3500
S0108-JJ20	3/4	6.00	15.50	0.62	1.03	5200
S0108-JJ25	1	6.00	19.00	0.75	1.23	10000
S0108-JJ25-1	1	12.00	24.00	0.75	1.23	10000
S0108-JJ32-1	1-1/4	12.00	24.00	1.00	1.80	15200

Note: Meets WLL and dimensions of ASTM specification F 1145-92 Type 1, Class G. Part #S0106-BDXX

Turnbuckle Eye and Eye

316 Stainless Steel Forged

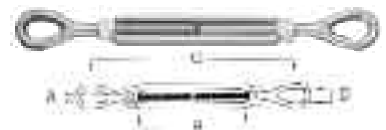

Item	Dimensions (in)			D	WLL (lbs)	Wt. (lbs)
	A	B	C			
S0107-EE07	1/4	4.00	7.50	0.45	500	0.38
S0107-EE08	5/16	4.50	8.50	0.50	800	0.45
S0107-EE10	3/8	6.00	10.75	0.51	1200	0.90
S0107-EE13	1/2	6.00	12.00	0.71	2200	1.40
S0107-EE16	5/8	6.00	13.50	0.87	3500	2.50
S0107-EE20	3/4	6.00	15.50	0.98	5200	3.90
S0107-EE25	1	6.00	19.00	1.35	10000	9.15

Note: Meets WLL and dimensions of ASTM specification F 1145-92 Type 1, Class D. Part #S0106-BDXX

Turnbuckle Jaw and Eye

316 Stainless Steel Forged



Item	Dimensions (in)					WLL (lbs)
	A	B	C	D	E	
S0109-JE07	1/4	4.00	7.50	0.45	0.45	500
S0109-JE08	5/16	4.50	8.50	0.50	0.51	800
S0109-JE10	3/8	6.00	10.75	0.51	0.54	1200
S0109-JE13	1/2	6.00	12.00	0.71	0.63	2200
S0109-JE16	5/8	6.00	13.50	0.87	0.82	3500
S0109-JE20	3/4	6.00	15.50	0.98	1.03	5200
S0109-JE25	1	6.00	19.00	1.35	1.23	10000

Note: Meets WLL and dimensions of ASTM specification F 1145-92 Type 1, Class H. Part #S0106-BDXX

Turnbuckle Hook and Eye

316 Stainless Steel Forged

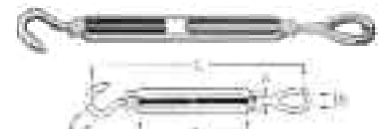

Item	Dimensions (in)					WLL (lbs)
	A	B	C	D	E	
S0110-HE07	1/4	4.00	7.50	0.45	0.37	100
S0110-HE08	5/16	4.50	8.50	0.50	0.44	250
S0110-HE10	3/8	6.00	10.75	0.51	0.50	450
S0110-HE13	1/2	6.00	12.00	0.71	0.63	750
S0110-HE16	5/8	6.00	13.50	0.87	0.63	1200
S0110-HE20	3/4	6.00	15.50	0.98	0.95	1500

Note: Meets WLL and dimensions of ASTM specification F 1145-92 Type 1, Class F. Body and eyes are forged. Hooks are formed and cold forged. Part #S0106-BDXX. Hook and hook also available use part #S0111-HHXX. Use above dimension. Class F.

Rigging Fittings

Stainless Steel Fittings

Turnbuckle Body 316 Stainless Steel Forged



Item	Dimensions (in)			WLL (lbs)	Thread
	A	B	C		
S0106-BD07	1/4	4.00	4.75	0.72	500 1/4 x 20
S0106-BD08	5/16	4.50	5.50	0.79	800 5/16 x 18
S0106-BD10	3/8	6.00	7.12	0.96	1200 3/8 x 16
S0106-BD13	1/2	6.00	7.50	1.15	2200 1/2 x 13
S0106-BD16	5/8	6.00	7.80	1.35	3500 5/8 x 11
S0106-BD20	3/4	6.00	8.10	1.68	5200 3/4 x 10
S0106-BD25	1	6.00	9.00	2.25	10000 1 x 8
S0106-BD25-1	1	12.00	15.00	2.25	10000 1 x 8
S0106-BD32-1	1-1/4	12.00	15.00	2.66	15200 1-1/4 x 7

Note: Meets WLL and dimensions of ASTM specification F 1145-92 Type 1.

Forged Shoulder Eye Bolt

316 Stainless Steel Forged



Item	Dimensions (in)			Thread	WLL (in)
	A	B	C		
S0314-0750	1/4	1.50	2.00	0.51 1/4-20	500
S0314-0710	1/4	2.25	4.00	0.51 1/4-20	500
S0314-0855	5/16	1.50	2.25	0.63 5/16-18	800
S0314-0810	5/16	2.50	4.25	0.63 5/16-18	800
S0314-1065	3/8	1.25	2.50	0.70 3/8-16	1200
S0314-1012	3/8	2.25	4.50	0.70 3/8-16	1200
S0314-1380	1/2	1.50	3.25	1.02 1/2-13	2200
S0314-1315	1/2	3.00	6.00	1.02 1/2-13	2200
S0314-1615	5/8	3.00	6.00	1.52 5/8-11	3500
S0314-2015	3/4	3.00	6.00	1.75 3/4-10	5200
S0314-2523	1	4.00	9.00	1.75 1-8	9400

Note: All threads are UNC, with machines shoulder pattern. Nut and washer are included.

Lifting Eye Bolt

316 Stainless Steel Precision Cast



Item	Dimensions (in)			WLL (lbs)	Wt. (lbs)
	A	B	C		
S0316-0007	1/4	1.09	0.64	0.55	400 0.05
S0316-0008	5/16	1.34	0.76	0.58	800 0.07
S0316-0010	3/8	1.68	0.96	0.71	1320 0.13
S0316-0013	1/2	2.09	1.14	0.86	2100 0.30
S0316-0016	5/8	2.47	1.34	1.02	3900 0.45
S0316-0020	3/4	2.83	1.58	1.14	6300 0.79
S0316-0025	1	3.60	1.98	1.31	9500 1.65
S0316-0032	1-1/4	5.22	2.85	2.20	11200 3.00
S0316-0038	1-1/2	6.00	3.26	2.57	15400 4.00
S0316-0050	2	7.63	4.08	3.18	24000 6.00

Note: Threads are also available in Titanium. Sizes to 4" available on special order.

Lifting Eye Nut

316 Stainless Steel Precision Cast



Item	Dimensions (in)			WLL (lbs)	Wt. (lbs)
	A	B	C		
S0321-0007	1/4	1.20	0.62	0.50	400 0.05
S0321-0008	5/16	1.55	0.81	0.63	800 0.10
S0321-0010	3/8	1.94	0.97	0.76	1320 0.15
S0321-0013	1/2	2.37	1.18	0.95	2100 0.25
S0321-0016	5/8	2.83	1.34	1.18	3900 0.50
S0321-0020	3/4	3.39	1.58	1.31	6300 0.75
S0321-0025	1	3.55	2.00	1.96	9500 1.30
S0321-0032	1-1/4	5.22	2.85	3.06	11200 2.80
S0321-0038	1-1/2	6.00	3.26	3.46	15400 3.70
S0321-0050	2	7.63	4.08	4.48	24000 5.00

Note: Threads are UNC. Also available in Titanium. Sizes to 4" available on special order.

Eye and Eye Swivel

316 Stainless Steel Precision Cast



Item	Dimensions (in)			WLL (lbs)	Wt. (lbs)
	A	B	C		
S0128-0004	5/32	0.43	0.50	2.00	150 0.12
S0128-0005	3/16	0.50	0.50	2.31	300 0.12
S0128-0006	1/4	0.56	0.56	2.56	600 0.12
S0128-0008	5/16	0.75	0.75	3.62	1100 0.29
S0128-0010	3/8	0.87	1.00	4.62	1540 0.55
S0128-0013	1/2	1.25	1.31	6.00	2640 1.25
S0128-0016	5/8	1.50	1.62	7.37	4750 2.10
S0128-0020	3/4	1.62	2.00	8.50	7000 3.40
S0128-0022	7/8	1.87	2.00	9.25	8000 5.02
S0128-0025	1	2.50	2.56	11.00	10000 8.73

Eye and Jaw Swivel

316 Stainless Steel Precision Cast



Item	Dimensions (in)			WLL (lbs)	Wt. (lbs)
	A	B	C		
S0155-0006	1/4	0.50	0.43	2.62	600 0.14
S0155-0008	5/16	0.62	0.62	3.62	1100 0.33
S0155-0010	3/8	0.75	0.87	4.62	1540 0.63
S0155-0013	1/2	1.00	1.12	6.00	2640 1.40
S0155-0016	5/8	1.25	1.37	7.37	4750 2.36
S0155-0020	3/4	1.50	1.62	8.62	7000 3.93

Note: No snag shackle pin available.

Jaw and Jaw Swivel

316 Stainless Steel Precision Cast



Item	Dimensions (in)			WLL (lbs)	Wt. (lbs)
	A	B	C		
S0156-0006	1/4	0.50	0.43	2.62	600 0.15
S0156-0008	5/16	0.62	0.62	3.62	1100 0.38
S0156-0010	3/8	0.75	0.87	4.62	1540 0.74
S0156-0013	1/2	1.00	1.12	6.00	2640 1.54
S0156-0016	5/8	1.25	1.37	7.37	4750 2.63
S0156-0020	3/4	1.50	1.62	8.58	7100 4.34

Note: No snag shackle pin available.

Clevis Grab Hook

316 Stainless Steel Forged

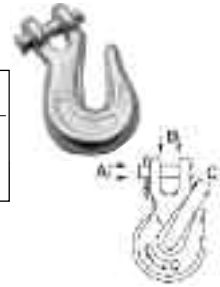

Item	Size (in)	Dimensions (in)			WLL (lbs)	Wt. (lbs)
		A	B	C		
S0451-0007	1/4	0.28	0.40	0.35	1500 0.37	
S0451-0008	5/16	0.37	0.46	0.45	2000 0.64	
S0451-0010	3/8	0.49	0.56	0.50	2500 0.90	
S0451-0013	1/2	0.62	0.70	0.65	3600 1.94	

Note: Working loads are based on gradual pull, not shock loads. Includes removable clevis pin.

Clevis Slip Hook

316 Stainless Steel Forged

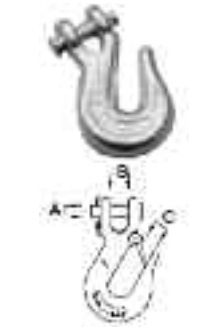

Item	Size (in)	Dimensions (in)			WLL (lbs)	Wt. (lbs)
		A	B	C		
S0452-0007	1/4	0.28	0.40	0.60	1000 0.42	
S0452-0008	5/16	0.37	0.46	0.63	1500 0.77	
S0452-0010	3/8	0.49	0.56	0.87	2000 1.17	
S0452-0013	1/2	0.62	0.70	1.00	3000 2.34	
Z0452-L007	1/4	REPLACEMENT LATCH				
Z0452-L008	5/16	REPLACEMENT LATCH				
Z0452-L010	3/8	REPLACEMENT LATCH				
Z0452-L013	1/2	REPLACEMENT LATCH				

Note: Working loads are based on gradual pull, not shock loads. Includes removable latch and clevis pin.

Eye Grab Hook

316 Stainless Steel Forged

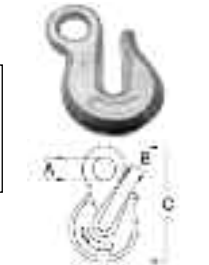

Item	Size (in)	Dimensions (in)			WLL (lbs)	Wt. (lbs)
		A	B	C		
S0453-0007	1/4	0.52	0.35	3.03	1500 0.28	
S0453-0008	5/16	0.64	0.45	4.05	2000 0.51	
S0453-0010	3/8	0.72	0.50	4.75	2500 0.76	
S0453-0013	1/2	0.93	0.65	6.25	3600 1.60	

Note: Working loads are based on gradual pull, not shock loads.

Stainless Steel Fittings/Farm Hardware

Eye Slip Hook

316 Stainless Steel Forged

Item	Size (in)	Dimensions (in)			WLL (lbs)	Wt. (lbs)
		A	B	C		
S0454-0007	1/4	0.52	0.62	3.50	1000	0.35
S0454-0008	5/16	0.64	0.70	4.05	1500	0.55
S0454-0010	3/8	0.72	0.79	4.75	2000	0.92
S0454-0013	1/2	0.93	1.06	6.00	3000	1.90
Z0454-L007	1/4	REPLACEMENT LATCH				
Z0454-L008	5/16	REPLACEMENT LATCH				
Z0454-L010	3/8	REPLACEMENT LATCH				
Z0454-L013	1/2	REPLACEMENT LATCH				

Note: Working loads are based on gradual pull, not shock loads. Includes Removable Latch.



Swivel Eye Hook

316 Stainless Steel Precisions Cast

Item	A	Dimensions (in)			WLL (lbs)	Wt. (lbs)
		B	C	D		
S0455-0100	4	0.67	0.26	0.87	770	0.42
S0455-0120	5	0.78	0.32	1.10	1430	0.72
S0455-0150	6	0.77	0.38	1.10	2200	1.16
S0455-0200	8	1.18	0.50	1.42	3300	2.34

Note: Working loads are based on gradual pull, not shock loads. Includes removable safety latch. Stamped with size and working load in "kgs"
Conversion: kg x 2.2 = lbs



Eye Hook

316 Stainless Steel Precision Cast

Item	A	Dimensions (in)			WLL (lbs)	Wt. (lbs)
		B	C	D		
S0194-0001	3/4	0.62	4.00	1.87	650	0.26
S0194-0002	1-1/8	0.81	4.75	2.12	1100	0.38

Note: Working loads are based on gradual pull, not shock loads. Includes removable safety latch.



Wire Rope Sheaves

316/304 Stainless Steel Precision Cast

Item	Size (in)	Dimensions (in)				Wt. (lbs)
		A	B	C	D	
S0400-W075	3	3.25	3/16	0.50	0.75	0.80
S0400-W100	4	4.25	1/4	0.63	0.94	1.32
S0400-W125	5	5.25	5/16	0.63	1.13	1.51
S0400-W150	6	6.00	3/8	0.75	1.25	2.20

Note: Bushes are pre-drilled to the above sizes. Custom bores can be done in our shop with short turn-around times. Please call with your specifications.



Rope Sheaves

316-304 Stainless Steel Precision Cast

Item	Size (in)	Dimensions (in)				Wt. (lbs)
		A	B	C	D	
S0400-0025	1	1.00	1/4	0.25	0.56	0.20
S0400-0032	1-1/4	1.25	5/16	0.31	0.63	0.25
S0400-0050	2	2.00	3/8	0.38	0.75	0.50
S0400-0075	3	3.25	1/2	0.50	0.75	0.80
S0400-0100	4	4.25	5/8	0.63	0.94	1.20
S0400-0125	5	5.25	3/4	0.63	1.13	1.51
S0400-0150	6	6.00	1	0.75	1.37	2.00

Note: Bushes are pre-drilled to the above sizes. Custom bores can be done in our shop with short turn-around times. Please call with your specifications.



FARM HARDWARE

CM Clevis with Zinc Plated Heat Treated Pins and Hairpin Locks

Extra strong – forge of high strength steel – extra tough.



Part Num	Body Size	WLL (lb)	Approx Weight Ea
Twist Clevis			
M8258	5/8	6000	1.5
M8234	3/4	12000	2.3
M8078	7/8	16000	3.0
M8278	7/8	16000	3.6
M8290	15/16	20000	4.2
M8295	1	25000	6.0
Straight Clevis			
M8158	5/8	6000	1.5
M8134	3/4	12000	2.3
M8878	7/8	16000	3.0
M8178	7/8	16000	3.6
M8190	15/16	20000	4.2
M8195	1	25000	6.0

CM No. M465 General Purpose Clevis

- Hot forged – with heat treated round pin for extra strength.
- 3/4" body and pin.
- Working load limit 10,000 lbs. maximum.
- Factory pack – 5.

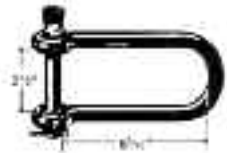

CM Loose Pin Utility Clevis

- M1548 and M1549 are used for joining hitch to harrow sections.
- Forged from high strength steel with heat treated alloy pin.



Part Num	Body Size	WLL (lb)	Approx Weight Ea
M1546	1/4	1000	.08
M1547	5/16	1500	.20
M1548	3/8	2000	.28
M1549	7/16	3000	.40
M1550	1/2	4000	.62
M1551	5/8	6500	1.2

SHIPYARD HOOKS

Shipyards Hooks - CM

Designed to be used with select steel body lever operated hoists in the ship building and metals fabrication industries. Available in 1-1/2 and 3 ton working load limit sizes, the upper Shipyards Hook quickly replaces the standard hook and features a special trunnion which attaches directly to the hoist body. The lower hook is equipped with a chain block for direct attachment to the load chain of the hoist. These Shipyards Hooks were designed to effectively position steel plate and fixtures before welding. Available only with a latch.



Prod. Code	Size (ton)	Desc.	WLL* (lbs)*	Finish	Wt. Ea. (lbs)
Upper Shipyards Hook					
3315WLP	1.5	1-1/2 Ton Upper Shipyards Hook	3,000	Black Paint	2.9
3303WLP	3.0	3 Ton Upper Shipyards Hook	6,000	Black Paint	4.9
Lower Shipyards Hook					
3415WLP	1.5	1-1/2 Ton Lower Shipyards Hook	3,000	Black Paint	2.1
3403WLP	3.0	3 Ton Lower Shipyards Hook	6,000	Black Paint	4.8

